

## Comparison of removal efficiency of pathogenic microbes in four types of wastewater treatment systems in Denmark



B. Adrados<sup>a</sup>, C.A. Arias<sup>c</sup>, L.M. Pérez<sup>a,b</sup>, F. Codony<sup>e</sup>, E. Bécares<sup>d</sup>, H. Brix<sup>c</sup>, J. Morató<sup>a,\*</sup>

<sup>a</sup> Health and Environmental Microbiology Laboratory – UNESCO Chair on Sustainability, Universitat Politècnica de Catalunya, Edifici Gaia Rambla Sant Nebridi 22, 08222 Terrassa, Barcelona, Spain

<sup>b</sup> Departamento de Investigación Institucional, Facultad de Química e Ingeniería del Rosario, Pontificia Universidad Católica Argentina (UCA)-CONICET, Av. Pellegrini 3314, 2000 Rosario, Argentina

<sup>c</sup> Aarhus University, Department of Bioscience, Ole Worms Allé 1, Building 1135, 8000 Århus C, Denmark

<sup>d</sup> Department of Biodiversity and Environmental Management, Faculty of Environmental and Biological Sciences, University of León, 24071, León, Spain

<sup>e</sup> Laboratori Municipal, Aigües de Mataró, Hèl·lade, 17-19, 08304, Mataró, Spain

### ARTICLE INFO

#### Keywords:

Constructed wetlands  
Biological sand filters  
Biofilters  
Wastewater treatment  
Bacterial indicators  
Removal of microbes

### ABSTRACT

The aim of the present work was to evaluate and compare the performance in the removal of pathogenic microbes in four different types of decentralized wastewater treatment systems, namely: horizontal flow constructed wetlands (HFCW), vertical flow constructed wetlands (VFCW), biological sand filters (BSF) and biofilters (BF). All the systems analyzed are located in Jutland, Denmark. Water sampling took place during a three months period that covered from winter to spring. Conventional microbial indicators such as *Escherichia coli*, total coliforms (TC), intestinal enterococci and sulphite-reducing clostridia were quantified using traditional microbiological culture methods, whereas *Bacteroides* spp. determination was performed by quantitative PCR (qPCR). Other water quality parameters such as dissolved oxygen, biological oxygen demand (BOD<sub>5</sub>), total suspended solids (TSS), pH, temperature, ammonium concentration and conductivity of influent and effluent water samples were also analyzed. The results showed that bacterial indicators significantly reduced in all the systems analyzed. In general, BF showed the best performance in the removal of microbes for all bacteria studied, while BSF demonstrated an improved capacity to eliminate *E. coli* and TC. Contrarily, VFCW seems to be more effective reducing the amount of intestinal enterococci, sulphite-reducing clostridia, and *Bacteroides* spp. In the present study, HFCW were the less efficient wastewater treatment system for the elimination of the evaluated pathogens. However, the performance in the removal of microbes was still significant considering that such systems were the oldest under operation (with over 20 years of continuous task).

### 1. Introduction

During the last decades, many researchers have focused their attention on the use of natural systems to remove pharmaceuticals, microorganisms, organic matter, and personal care products from urban wastewater. Constructed wetlands (CW), biological sand filters (BSF) and biofilters (BF) have been proven to be an effective technology able to reduce pollution generated from wastewaters, runoff, and other types of pollutants in waters, being specially designed to solve wastewater treatment needs where the centralized systems are not economically or technically viable (Hedmark and Scholz, 2008; Vymazal and Kröpfelová, 2009; Vymazal, 2011; Kurzbaum et al., 2012). In particular, these water treatment technologies have been used in Denmark for > 20 years, and are still being established with very good results to

comply with the stringent Danish discharge demands. Horizontal flow constructed wetlands (HFCW) have been used since the early 1980 to treat domestic wastewater generated in urban areas from around 200 Danish municipalities (Brix et al., 2007). The selection of this technology was influenced by the apparent low building costs and minimum operation and maintenance needs, as well as its expected effective performance to treat waters from different origins (Uhl and Dittmer, 2005; Healy et al., 2007; Babatunde et al., 2008; Vymazal and Kröpfelová, 2009). Unfortunately, after some years of implementation most of such systems presented operational problems (clogging), and the pollutants removal expectations were not totally fulfilled. Furthermore, in 1997, Denmark emitted new and more stringent requirements for wastewater treatment that made HFCW obsolete. Following local research and foreign experiences new constructed wetland

\* Corresponding author.

E-mail address: [jordi.morato@upc.edu](mailto:jordi.morato@upc.edu) (J. Morató).

**Table 1**

Specific details of household wastewater treatment systems analyzed at the present study. VFCW and BSF are unsaturated systems; therefore, residence time is about some hours.

Location	System	Planted*	Area (m <sup>2</sup> )	P.E.** served	Recirculation	Phosphorous removal	TRH*** (days)	Years of operation	Organic loading (g/m <sup>2</sup> d)
Bjødstrup	HFCW1	Yes	470	80	No	No	6.12	> 20	8.2
Gronfeld	HFCW2	Yes	1800	220	No	No	42.6	> 20	12.3
Friland	VFCW1	Yes	90	30	Yes	No	< 1	2	20
Tisset	VFCW2	Yes	16	2	No	Chemical	< 1	4	4.7
Astrup	VFCW3	Yes	16	4	Yes	Chemical	< 1	5	15
Logenskovvej	BSF1	No	26	5	Yes	Yes	< 1	5	12
Bojenskovvej	BSF2	No	26	6	No	Chemical	< 1	2	9.8
Friland	BF1	No	50	4	No	Filtralite® P	31	6	4.8
Hanne's	BF2	No	50	6	Yes	Filtralite® P	20.6	6	7.2

\* Planted systems with *Phragmites australis*.

\*\* P.E.: person equivalent.

\*\*\* TRH: hydraulic residence time.

developments were investigated and implemented; and finally, in 2004, the Danish Environmental Protection Agency (EPA) published a series of guidelines for the design and construction of vertical flow constructed wetlands (VFCW) (Brix and Arias, 2005a,b). Since then, around 1000 VFCW have been built across the country.

Biological sand filters (BSF) are another technological solution for decentralized domestic wastewater treatment frequently used in different countries around the world (Healy et al., 2007; Bali et al., 2011; Stauber et al., 2012). These systems were widely used in Denmark since 1997 to treat domestic wastewater, and currently this technology is nationally accepted (Brix and Arias, 2005a,b). BSF use similar operational principles than VFCW but the construction guidelines suggest the need of larger treatment surfaces and therefore higher construction costs.

Biofilters (BF) are a different technology developed in Norway during the early 90s to meet the needs exerted by the unfavourable climatic conditions for plant development where constructed wetlands could not achieve their full potential. BF pollutant removal mechanisms rely on the combination of oxic-anoxic environments and the use of specific light weight aggregates and specific media (Filtralite-P®) to remove phosphorus (Jenssen et al., 2010). There are only two BF constructed in Denmark that were built in 2003 as a part of an industrial sponsored research initiative looking for a common decentralized wastewater treatment solution at the Nordic countries. The high construction costs of such systems combined with the possibility to use other equally efficient and more economical alternatives to wastewater treatment explains why no more BF have been constructed in Denmark since then. However, BF are still widely used in Norway and Sweden.

Sanitary risk is directly associated with the presence of microbial pathogens in waters, especially those present in untreated wastewater. Pathogenic organisms should be removed before water discharge to the environment in order to ensure population safety (Graczyk and Lucy, 2007). The reuse of treated wastewater is also a major challenge as global warming increases and water scarcity increases, especially in warm latitudes. In general, natural wastewater treatment systems are not designed but for secondary treatment, and not to remove microbial pollution. It is known that these systems could act as excellent bacterial sinks through a combination of complex physical, chemical and biological factors that actively participate in the reduction of the number of bacteria present in water (Vymazal, 2005; Wu et al., 2016). In the last 15 years, significant resources have been invested to improve the understanding of the mechanisms involved in the removal of microbes at decentralized systems (Arias et al., 2003; Hansen et al., 2004; Ibekwe et al., 2003; Karim et al., 2004; Vacca et al., 2005; Winward et al., 2008; Adrados et al., 2014; Morató et al., 2014; Wu et al., 2016; Alexandros and Akratos, 2016; Akunna et al., 2017). However, there is still a lack of information from comparative studies evaluating the removal of microbes between natural wastewater treatment systems actively working during long-term operation periods.

Therefore, the aim of the present work was to evaluate the performance in the removal of conventional indicator organisms and pathogenic microbes (*Escherichia coli*, total coliforms, intestinal enterococci, sulphite-reducing clostridia and *Bacteroides* spp.) for a series of different non-conventional wastewater treatment systems (HFCW, VFCW, BSF and BF) located at Denmark. In addition, systems capability to improve wastewater physicochemical parameters was also considered.

## 2. Material and methods

### 2.1. Site description

Samples were taken from real-operating decentralized wastewater treatment systems constructed in the vicinity of Aarhus (Jutland, Denmark). All the selected systems have been effectively functioning for several years and are representative of similar systems used all over the world. The analyzed systems correspond to horizontal flow constructed wetlands (HFCW), vertical flow constructed wetlands (VFCW), biological sand filters (BSF) and biofilters (BF) with expanded clay aggregate as filtering and bed material. The operative and design characteristics are shown in Table 1. A general scheme of each kind of treatment system is presented in Fig. 1.

### 2.2. Sample collection

Grab samples were collected between March and June (2014) in three sampling campaigns (approximately one per month) over three consecutive days ( $n = 9$ ); except for BF where the first campaign did not take place ( $n = 6$ ). Influent and effluent water samples were collected from each system in 1 L sterile glass bottles and transported under refrigeration (4 °C) to the laboratory within 24 h for the microbiological analysis.

### 2.3. Physicochemical parameters

Water temperature, dissolved oxygen (O<sub>2</sub>), pH and electric conductivity were measured *in-situ* using commercially available calibrated electrodes (Hach Lange BmbH, Barcelona). Samples were immediately transported under refrigeration to the laboratory of the Department of Bioscience (Aarhus University) for further analysis. Additional water quality parameters evaluated included total suspended solids (APHA 2540 D method), ammonia nitrogen (APHA 4500 NH<sub>3</sub> D method) and BOD<sub>5</sub> (APHA 5210B method) (APHA, 2012).

### 2.4. Microbiological analyses

Total coliforms, *E. coli* and intestinal enterococci were determined by the membrane filtration method (0.45 µm pore size sterile cellulose, Millipore, MA, USA) with subsequent colony counting, and were

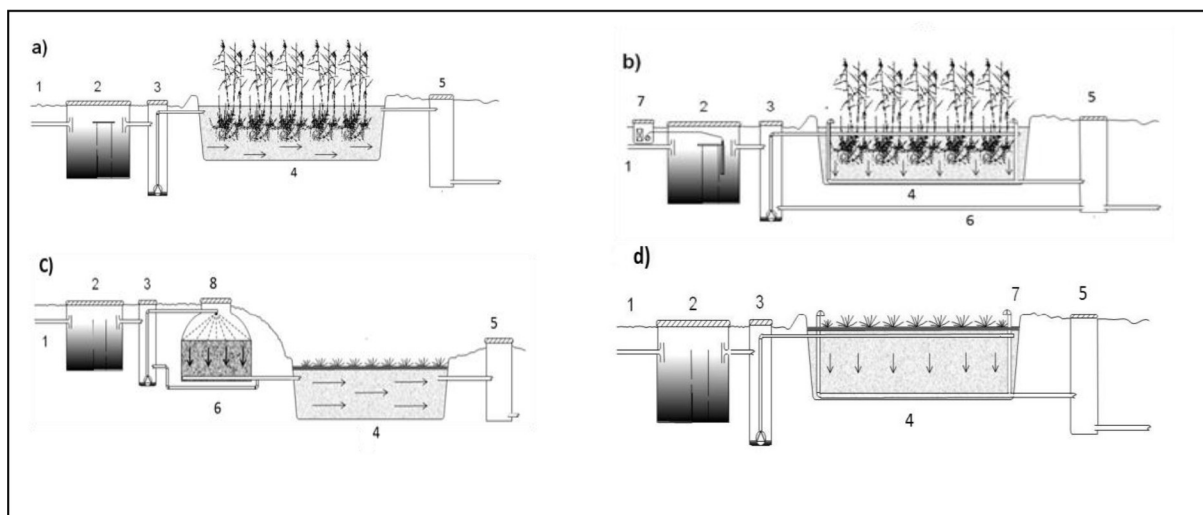

**Fig. 1.** Schemes of the four types of wastewater treatment systems studied at the present work: a) horizontal flow constructed wetlands (HFCW), b) vertical flow constructed wetlands (VFCW), c) biofilters (BF), and d) biological sand filters (BSF). 1) inlet, 2) sedimentation tank, 3) pumping well, 4) bed, 5) outlet well, 6) recycling, 7), phosphorus removal system, 8) light weight aggregates dome biofilters. Arrows indicate water flow.

expressed as colony forming units (CFU/100 mL). Total coliforms and *E. coli* were detected and enumerated incubating the membranes in Chromocult coliform agar (Merck, Darmstadt, Germany) for 24 h at 37 °C (Byamukama et al., 2000). Intestinal enterococci were enumerated using Slanetz-Bartley selective agar (Merck, Darmstadt, Germany) and incubating the membranes for 48 h at 37 °C (ISO 7899-2, 2000). Sulphite-reducing clostridia were enumerated by membranes transfer onto S.P.S. agar surface (Merck, Darmstadt, Germany) and incubating the plates inverted for 48 h at 37 °C under anaerobic conditions. For each bacterial group analyzed, the samples were properly diluted before being cultured on the specified media. Experiments were performed in duplicate.

## 2.5. Quantitative PCR (qPCR)

*Bacteroides* spp. levels were analyzed by quantitative PCR (qPCR). Up to 100 mL of water sample (50 mL for some effluents) were concentrated by membrane filtration using a nylon membrane (0.45 µm pore diameter, Millipore, MA, USA). Cells were resuspended in 5 mL of sterile saline solution (0.9% NaCl), vigorously vortexed for 60 s in the presence of 15 glass spheres (5 mm diameter), and further treated during 3 min in an ultrasonic water bath (150 W-6L, JP Selecta, Spain). Suspensions (4 mL) were concentrated to 200 µL by centrifugation (8000g, 5 min). DNA was extracted using the E.Z.N.A. Tissue DNA kit (Omega Bio-Tek, Doraville, USA) according to manufacturer's instructions. The specific primers used for DNA amplification were those described by Layton et al. (2006). Since different kits can lead to different levels of target gene (Nölvak et al., 2012) the PCR protocol was previously adapted and optimized to our thermal cycler and reagents and verified according to Pérez et al., 2013. Quantification was performed using real-time PCR with the LightCycler 1.5 PCR system (Roche Applied Science, Mannheim, Germany).

## 2.6. Statistical analyses

Statistical analyses were performed using the StatGraphics Centurion XV program (Statpoint, Herndon, VA, USA). The normality of the variables was verified to support the use of parametric tests. One-way ANOVA analysis was used to evaluate the existence of significant differences ( $p < 0.05$ ) between the four different types of treatment systems evaluated. The difference of means between groups was resolved via confidence intervals using Tukey's test. The significance level was set at  $p < 0.05$ . The non-parametric Kruskal-Wallis test was

applied when data could not be adjusted to a normal distribution.

## 3. Results and discussion

### 3.1. Physicochemical parameters

Water samples from all the treatment systems under study were taken from March to June 2014. During this 3-month period the ambient temperature in Aarhus varied from 0 °C in the first campaign (March) to 16 °C in the third one (June). This temperature increase has some effect on water temperature inside the systems which, despite remaining relatively constant, showed an increase of 5 °C in the influent samples and 6–7 °C in the effluent samples (i.e., from the first to the third sampling campaign). Although, physicochemical characteristics of the influent water were different for each decentralized system under evaluation all treatments were effective to improve effluent water quality (Table 2). The efficiency of BOD<sub>5</sub> removal was high in all the systems analyzed with average removals ranging from 90% to 99%. However, our results showed a clear tendency for a better performance in BOD<sub>5</sub> removal for BF and VFCW systems compared with BSF and HFCW ( $p = 0.01$ ). The removal of NH<sub>4</sub>-N follows a similar trend being VFCW the most effective treatment systems, showing average removal rates around 99%. In contrast, the saturated HFCW systems only presented an ammonia removal capability that ranges between 30 and 60%. Similar results were obtained for TSS elimination. In this case, VFCW showed the best performance for suspended solids elimination in comparison with the other treatments analyzed ( $p = 0.03$ ). All these facts can be explained since BF and VFCW operate with unsaturated beds with higher availability for O<sub>2</sub> and, therefore, aerobic processes involved in organic matter elimination and nitrification are facilitated. As can be seen in Table 2, highest O<sub>2</sub> concentrations were found for VFCW and BSF whereas the lowest were verified for BF. This observation can be explained by the fact that BF have two sections. The first one is intended to remove organic matter and nitrogen, and operates in an unsaturated manner. The second section is a 49 m<sup>2</sup> bed with 1 m deep filled with Filtralite-P®, intended to retain inorganic phosphorus before water discharge. This configuration produces a hydraulic retention time (> 20 days) that is long enough to deplete the dissolved oxygen present in the water.

### 3.2. Microbial indicators

Bacterial indicators were significantly reduced in all systems

**Table 2**  
Physicochemical characteristics of influent and effluent water samples.

System	Influent (mg/l)						Effluent (mg/l)					
	TSS	BOD <sub>5</sub>	NH <sub>4</sub> -N	O <sub>2</sub>	pH	Conduct.	TSS	BOD <sub>5</sub>	NH <sub>4</sub> -N	O <sub>2</sub>	pH	Conduct.
HFCW1	89 ± 31	294 ± 35	79 ± 26	0.3 ± 0.2	6.9 ± 0.2	1256 ± 186	5.7 ± 1.8	2.6 ± 0.9	31 ± 9	6.0 ± 0.5	7.0 ± 0.3	981 ± 188
HFCW2	90 ± 39	188 ± 163	28 ± 11	2.1 ± 1.1	7.2 ± 0.3	1018 ± 194	19 ± 12	16 ± 8.1	19 ± 4	4.7 ± 1.8	7.1 ± 0.3	847 ± 158
VFCW1	57 ± 25	163 ± 38	80 ± 33	0.5 ± 0.1	7.2 ± 0.3	1481 ± 101	9.3 ± 5	1.3 ± 1.2	0.5 ± 0.4	4.8 ± 2.3	7.3 ± 0.3	1155 ± 168
VFCW2	92 ± 35	243 ± 90	91 ± 28	0.5 ± 0.2	7.3 ± 0.4	1440 ± 95	8.4 ± 2.2	3.0 ± 2.7	0.5 ± 0.4	7.0 ± 4.0	7.1 ± 0.2	1183 ± 185
VFCW3	110 ± 22	250 ± 56	57 ± 26	0.5 ± 0.1	7.4 ± 0.2	1248 ± 238	4.4 ± 2.2	1.3 ± 0.5	1.2 ± 1.0	7.4 ± 2.0	7.3 ± 0.2	1328 ± 118
BSF1	95 ± 2	240 ± 56	99 ± 32	0.4 ± 0.1	7.1 ± 0.3	2177 ± 573	17 ± 10	18 ± 10	4.9 ± 7	8.6 ± 0.6	7.1 ± 0.4	1477 ± 350
BSF2	113 ± 37	237 ± 59	153 ± 71	0.5 ± 0.1	6.8 ± 0.3	1205 ± 87	15 ± 5	4.7 ± 4.6	34 ± 25	3.8 ± 1.8	6.9 ± 0.3	1001 ± 90
BF1	70 ± 13	198 ± 36	74 ± 22	2.4 ± 1.5	7.2 ± 0.4	1050 ± 95	4.1 ± 2.5	1.6 ± 0.9	30 ± 6	1.2 ± 0.2	8.6 ± 0.3	764 ± 43
BF2	94 ± 24	310 ± 179	101 ± 15	0.5 ± 0.2	7.3 ± 0.3	1802 ± 124	26 ± 26	1.8 ± 0.4	8.9 ± 5	1.8 ± 0.4	7.1 ± 0.3	1256 ± 77

TSS = total suspended solids; BOD<sub>5</sub> = biological oxygen demand; NH<sub>4</sub>-N, ammonia nitrogen, O<sub>2</sub> = dissolved oxygen.

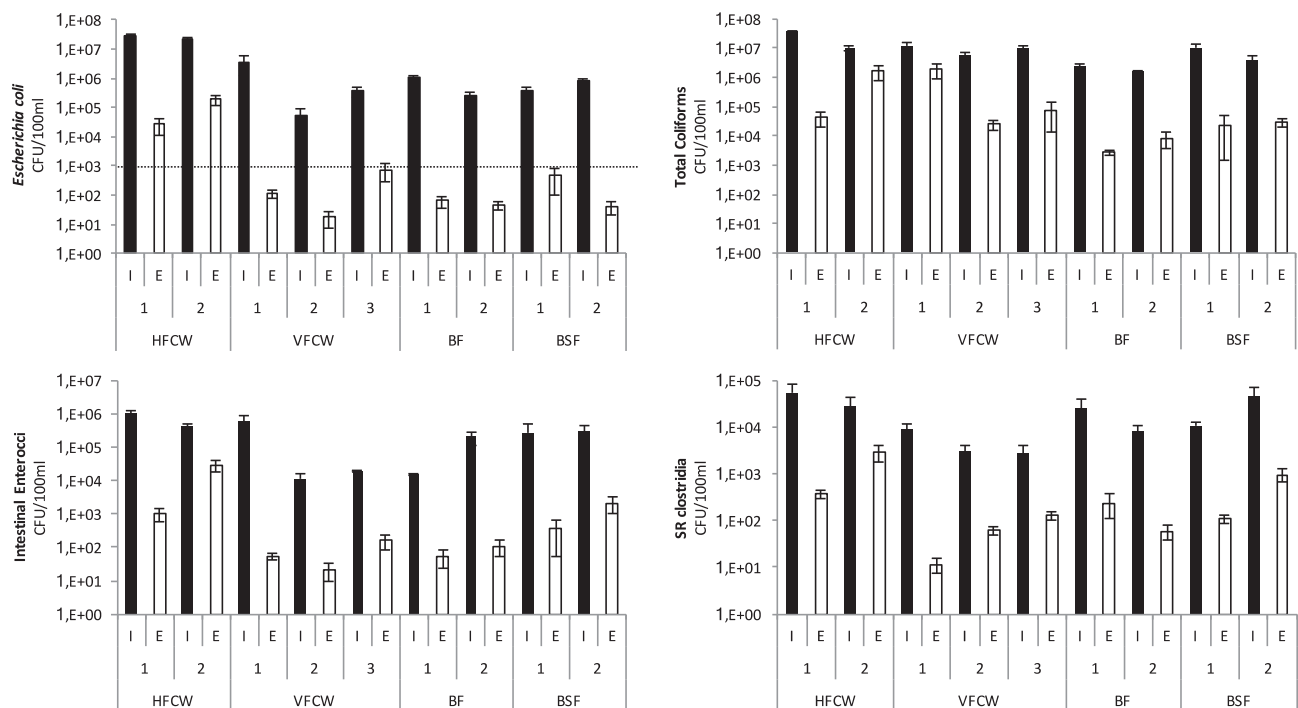

**Fig. 2.** Removal of microbes in horizontal flow constructed wetlands (HFCW), vertical flow constructed wetlands (VFCW), biological sand filters (BSF) and biofilters (BF). Influent (I, black) and effluent (E, white) water samples were analyzed for *E. coli*, total coliforms, intestinal enterococci, sulphite-reducing (SR) clostridia and *Bacteroides* spp. 1, 2 or 3 are the number of system analyzed. Dotted line represents the recommended *E. coli* threshold values for wastewater use in agriculture (WHO, 2006).

**Table 3**  
Removal of microbes (log<sub>10</sub> CFU/100 mL) for horizontal flow constructed wetlands (HFCW), vertical flow constructed wetlands (VFCW), biological sand filters (BSF) and biofilters (BF).

	<i>E. coli</i>	Total coliforms	Intestinal enterococci	Sulphite-reducing clostridia	<i>Bacteroides</i> spp.
HFCW	2.70 ± 1.05 <sup>b</sup>	2.30 ± 1.26 <sup>c</sup>	2.97 ± 0.80 <sup>a</sup>	1.41 ± 0.68 <sup>b</sup>	2.07 ± 0.70 <sup>a</sup>
VFCW	3.35 ± 0.88 <sup>b</sup>	2.41 ± 1.27 <sup>bc</sup>	3.10 ± 0.96 <sup>a</sup>	1.83 ± 1.03 <sup>a</sup>	2.51 ± 0.69 <sup>a</sup>
BSF	4.12 ± 0.92 <sup>a</sup>	2.91 ± 0.92 <sup>ab</sup>	2.84 ± 1.10 <sup>a</sup>	1.77 ± 0.57 <sup>ab</sup>	2.44 ± 0.54 <sup>a</sup>
BF	4.06 ± 0.62 <sup>a</sup>	3.16 ± 0.81 <sup>a</sup>	3.34 ± 0.64 <sup>a</sup>	2.08 ± 0.39 <sup>a</sup>	2.58 ± 1.44 <sup>a</sup>

Different letters at same column represent statistically significant differences (*p* < 0.05).

analyzed. Differences in the removal of microbes between the three sampling campaigns were expected, especially for both types of constructed wetlands (VFCW and HFCW) where the effect of the plants on the bacterial removal may be inactive in the first campaign (at winter) and more vigorous in the last one (during the spring) (Karathanasis et al., 2003; Stottmeister et al., 2003; Vacca et al., 2005). However, no plant effect was evident between the two types of CW over the three campaigns (data not shown). Therefore, it was possible to process and

analyze all the data collected in order to compare the performance in the bacterial elimination for each treatment system independently of the sampling campaign. As can be seen in Fig. 2, bacterial indicator concentrations at influent and effluent water samples were variable for each system but, in general, removal efficiencies were higher than 90% in all cases. However, this high performance was not necessary related with low bacteria count at the outflows. In order to compare the efficiency in the removal of microbes between the different types of

wastewater treatment systems analyzed the logarithm of the average removal rates are presented in Table 3. Both BF and BSF were equally effective in *E. coli* removal showing significant differences ( $p < 0.05$ ) compared to HFCW and VFCW. A similar trend was observed for TC removal, where again BF and BSF seems to be the most effective systems.

Regarding intestinal enterococci and *Bacteroides* spp. removal, no statistically significant differences were found between all treatments systems. However, a slight performance improvement could be detected for BF and VFCW. A similar trend was observed in sulphite-reducing clostridia elimination, although statistically significant differences were only observed for BF vs. HFCW, and VFCW vs. HFCW. All these results are in agreement with existing data about the performance in the removal of microbes for wastewater treatment systems similar to those evaluated at the present study (Gerba et al., 1999; Karim et al., 2004; Ulrich et al., 2005; Reinoso et al., 2008). Vymazal (2005) presented removal efficiencies and first-order aerial rates recorded for different CW in-use at the time of the study. This author informed removal efficiencies for four different indicator organisms (total coliforms, faecal coliforms, faecal streptococci and *E. coli*) ranging from 65% to 99%, where the highest removal rates were observed for hybrid systems, followed by HFCW, and lastly free water surface (FWS) systems. In his study, VFCW were not included.

In general, BF was the decentralized wastewater treatment system with the higher organic matter and bacterial removal efficiencies, whereas HFCW was the one that showed the lower performance in the removal of indicator microorganisms.

Pathogen treatment in wetlands relies on different mechanisms including sedimentation, natural die-off, temperature, oxidation processes, predation, water chemistry, adhesion to biofilm, mechanical filtration, exposure to biocides and UV radiation (Gerba et al., 1999; Vymazal, 2005; Alexandros and Akratos, 2016). With all these mechanisms in mind, some of the most prevalent latent variables that are not described with a simple first-order aerial based rate constant are substrate type, plant type, microbial ecology and activity within the CW system, biofilm interactions, temperature, incoming water quality, and wetland depth. Although many other variables could be identified, this short list has been restricted to provide an overview about the most prevalent and obvious.

In our case, BF with expanded clay aggregate and BSF showed best results for *E. coli*, TC and *Bacteroides* spp. In addition, BF was the most efficient system for intestinal enterococci and sulphite-reducing clostridia elimination followed by VFCW, whereas HFCW was the system with the worst performance in bacterial removal. Key factors that can explain these higher efficiencies for BF can be the combination of long hydraulic retention time ( $> 20$  days), the operation in two sections, and the material used (Filtralite-P®). Moreover, fine granulometry for both BF and BSF can be another important factor that strongly influenced and improved the removal of microbes. In a previous study, the effect of the granulometry was also significant for *E. coli* and TC removal in HFCW, but this factor did not affect the elimination of *Clostridium* spores (Morató et al., 2014). In the present study, the higher specific surface area available for microbial attachment in the fine medium could explain the better performance observed for BF and BSF.

The efficiency of the removal of microbes is basic for Public Health and especially if we want to promote water reuse. An integral management of water resources should take into account the establishment of a circular economy approach, reusing all treated effluents although ensuring no health risks. In that sense, all the systems tested with the exception of the HFCW, could be used for unrestricted irrigation crops (vegetable and salad crops) because *E. coli* levels at the outlet were lower than  $10^3$  CFU/100 mL, considering the recommended minimum verification monitoring of microbial performance targets for wastewater and excreta use in agriculture (WHO, 2006). However, the HFCW could be used for drip irrigation, considering the same standards.

Additionally, it is noteworthy that, at the present study, *Bacteroides*

spp. detection using quantitative PCR have shown similar trends to that obtained for the indicator microorganisms (i.e., *E. coli* and TC) using conventional microbiology techniques. Knowing the limitations of the traditional indicator microorganisms in order to assess the risk to human health due to the potential presence of pathogenic bacteria in water samples, *Bacteroides* spp. determination could be an attractive alternative for a more real quantification of the microbial health risk (Ahmed et al., 2016). Moreover, *Bacteroides* are constituents of a larger portion of faecal bacteria compared to *E. coli* or *Enterococcus* spp. (Kreider, 1995; Sghir et al., 2000).

#### 4. Conclusions

In general, all the non-conventional wastewater treatment systems analyzed in this study were highly efficient to remove both physico-chemical and bacterial indicators from urban wastewaters. From our results, BF appears to be a more effective technology than HFCW, VFCW or BSF for the reduction of BOD<sub>5</sub>, TSS, and pathogenic microbes from wastewater; although these differences were not always statistically significant. In contrast, HFCW proved to be the less effective technology for the removal of all parameters analyzed but, at the same time, these systems are the oldest at functioning. Our preliminary analysis has been rather broad and mainly descriptive; however, in our opinion, it represents one of the first efforts to compare the performance in the removal of microbes for a substantial number of real-operating natural treatment systems, through considering a considerable array of data.

#### Acknowledgements

This study was supported by grants of the Ministry of Science and Innovation of Spain (project CTM2005-06457-C05-05) and the Alfa Network TECSPAR (RED ALFA II-0543-FI-FAFCD; Sustainable technologies for potabilization and wastewater treatment). Bárbara Adrados was funded with the program of pre-doctoral scholarships from the Ministry of Education and Science of Spain.

#### References

- Adrados, B., Sánchez, O., Arias, C.A., Bécarea, E., Garrido, L., Mas, J., Brix, H., Morató, J., 2014. Microbial communities from different types of natural wastewater treatment systems: vertical and horizontal flow constructed wetlands and biofilters. *Water Res.* 55, 304–312. <https://doi.org/10.1016/j.watres.2014.02.011>.
- Ahmed, W., Hughes, B., Harwood, V.J., 2016. Current status of marker genes of *Bacteroides* and related taxa for identifying sewage pollution in environmental waters. *Water* 8 (6), 231. <https://doi.org/10.3390/w8060231>.
- Akunna, J.C., O'Keefe, J.M., Allan, R., 2017. Reviewing factors affecting the effectiveness of decentralised domestic wastewater treatment systems for phosphorus and pathogen removal. *Des. Wat. Treat* 91, 40–47. <https://doi.org/10.5004/dwt.2017.20750>.
- Alexandros, S.I., Akratos, C.S., 2016. Removal of pathogenic bacteria in constructed wetlands: mechanisms and efficiency. In: Ansari, A., Gill, S., Gill, R., Lanza, G., Newman, L. (Eds.), *Phytoremediation*. Springer, Cham. [https://doi.org/10.1007/978-3-319-41811-7\\_17](https://doi.org/10.1007/978-3-319-41811-7_17).
- American Public Health Association (APHA), 2012. *Standard Method for Examination of Water and Wastewater*, 21st ed. APHA, AWWA, WPCF, Washington.
- Arias, C.A., Cabello, A., Brix, H., Johansen, N.H., 2003. Removal of indicator bacteria from municipal wastewater in an experimental two-stage vertical flow constructed wetland system. *Water Sci. Technol.* 48 (5), 35–41.
- Babatunde, A.O., Zhao, Y.Q., O'Neill, M., O'Sullivan, B., 2008. Constructed wetlands for environmental pollution control: a review of developments, research and practice in Ireland. *Environ. Int.* 34 (1), 116–126. <https://doi.org/10.1016/j.envint.2007.06.013>.
- Bali, M., Gueddari, M., Boukchina, R., 2011. Removal of contaminants and pathogens from secondary effluents using intermittent sand filters. *Water Sci. Technol.* 64 (10), 2038–2043. <https://doi.org/10.2166/wst.2011.448>.
- Brix, H., Arias, C.A., 2005b. Danish guidelines for small-scale constructed wetland systems for onsite treatment of domestic sewage. *Water Sci. Technol.* 51 (9), 1–9.
- Brix, H., Arias, C.A., 2005a. The use of vertical flow constructed wetlands for on-site treatment of domestic wastewater: New Danish guidelines. *Ecol. Eng.* 25 (5), 491–500. <https://doi.org/10.1016/j.ecoleng.2005.07.009>.
- Brix, H., Schierup, H.-H., Arias, C.A., 2007. Twenty years experience with constructed wetland systems in Denmark – what did we learn? *Water Sci. Technol.* 56 (3), 63–68. <https://doi.org/10.2166/wst.2007.522>.

- Byamukama, D., Kansime, F., Mach, R.L., Farnleitner, A.H., 2000. Determination of *Escherichia coli* contamination with Chromocult coliform agar showed a high level of discrimination efficiency for differing fecal pollution levels in tropical waters of Kampala, Uganda. *Appl. Environ. Microbiol.* 66, 864–868. <https://doi.org/10.1128/AEM.66.2.864-868.2000>.
- Gerba, C.P., Thurston, J.A., Falabi, J.A., Watt, P.M., Karpiscak, M.M., 1999. Optimization of artificial wetland design for the removal of indicator microorganisms and pathogenic protozoa. *Water Sci. Technol.* 40 (4–5), 363–368. [https://doi.org/10.1016/S0273-1223\(99\)00519-3](https://doi.org/10.1016/S0273-1223(99)00519-3).
- Graczyk, T.K., Lucy, F.E., 2007. Quality of reclaimed waters; a public health need for the source-tracking of wastewater-derived protozoan enteropathogens in engineered wetlands. *Trans. R. Soc. Trop. Med. Hyg.* 101 (6), 532–533. <https://doi.org/10.1016/j.trstmh.2007.02.018>.
- Hansen, D.L., Brix, H., Arias, C.A. (2004). Comparison of faecal coliform removal in different types of constructed wetland systems and other low technology systems. In: *Proceedings of the 9th International Conference on Wetland Systems*, Avignon, France.
- Healy, M.G., Rodgers, M., Mulqueen, J., 2007. Treatment of dairy wastewater using constructed wetlands and intermittent sand filters. *Bioresour. Technol.* 98 (12), 2268–2281. <https://doi.org/10.1016/j.biortech.2006.07.036>.
- Hedmark, A., Scholz, M., 2008. Review of environmental effects and treatment of runoff from storage and handling of wood. *Bioresour. Technol.* 99 (14), 5997–6009. <https://doi.org/10.1016/j.biortech.2007.12.042>.
- Ibekwe, A.M., Grieve, C.M., Lyon, S., 2003. Characterization of microbial communities and composition in constructed dairy wetland wastewater effluent. *Appl. Environ. Microbiol.* 69 (9), 5060–5069. <https://doi.org/10.1128/AEM.69.9.5060-5069.2003>.
- Jenssen, P.D., Krogstad, T., Paruch, A.M., Mahlum, T., Adam, K., Arias, C.A., Heistad, A., Jonsson, L., Hellström, D., Brix, H., Yli-Halla, M., Vrale, L., Valver, M., 2010. Filter bed systems treating domestic wastewater in Nordic countries—performances and reuse of filter media. *Ecol. Eng.* 36 (12), 1651–1659. <https://doi.org/10.1016/j.ecoleng.2010.07.004>.
- Karathanasis, A.D., Potter, C.L., Coyne, M.S., 2003. Vegetation effects on fecal bacteria, BOD, and suspended solid removal in constructed wetlands treating domestic wastewater. *Ecol. Eng.* 20 (2), 157–169. [https://doi.org/10.1016/S0925-8574\(03\)00011-9](https://doi.org/10.1016/S0925-8574(03)00011-9).
- Karim, M.R., Manshadi, F.D., Karpiscak, M.M., Gerba, C.P., 2004. The persistence and removal of enteric pathogens in constructed wetlands. *Water Res.* 38 (7), 1831–1837. <https://doi.org/10.1016/j.watres.2003.12.029>.
- Kreider, C.A., 1995. Design and evaluation of *Bacteroides* DNA probes for the specific detection of human fecal pollution. *Appl. Environ. Microbiol.* 66, 2263–2266.
- Kurzbaum, E., Kirzhner, F., Armon, R., 2012. Improvement of water quality using constructed wetland systems. *Rev. Environ. Health* 27 (1), 59–64. <https://doi.org/10.1515/revh-2012-0005>.
- Layton, A., McKay, L., Williams, D., Garrett, V.R., Sayler, G., 2006. Development of *Bacteroides* 16S rRNA gene TaqMan-based real-time PCR assays for estimation of total, human, and bovine faecal pollution in water. *Appl. Environ. Microbiol.* 72 (6), 4214–4224.
- Morató, J., Codony, F., Sánchez, O., Pérez, L.M., García, J., Mas, J., 2014. Key design factors affecting microbial community composition and pathogenic organisms removal in horizontal subsurface flow constructed wetlands. *Sci. Total Environ.* 481, 81–89. <https://doi.org/10.1016/j.scitotenv.2014.01.068>.
- Nölvak, H., Truu, M., Truu, J., 2012. Evaluation of quantitative real-time PCR workflow modifications on 16S rRNA and tetA gene quantification in environmental samples. *Sci. Total Environ.* 426, 351–358. <https://doi.org/10.1016/j.scitotenv.2012.03.054>.
- Pérez, L.M., Fittipaldi, M., Adrados, Morató, J., Codony, F., 2013. Error estimation in environmental DNA targets quantification due to PCR efficiencies differences between real samples and standards. *Folia Microbiol.* 58, 657–662. <https://doi.org/10.1007/s12223-013-0255-5>.
- Reinoso, R., Torres, L.A., Bécares, E., 2008. Efficiency of natural systems for removal of bacteria and pathogenic parasites from wastewater. *Sci. Total Environ.* 395 (2–3), 80–86. <https://doi.org/10.1016/j.scitotenv.2008.02.039>.
- Sghir, A., Gramet, G., Suau, A., Rochet, V., Pochart, P., Dore, J., 2000. Quantification of bacterial groups within human faecal flora by oligonucleotide probe hybridization. *Appl. Environ. Microbiol.* 66, 2263–2266.
- Stauber, C.E., Printy, E.R., McCarty, F.A., Liang, K.R., Sobsey, M.D., 2012. Cluster randomized controlled trial of the plastic BioSand Water filter in Cambodia. *Environ. Sci. Technol.* 46 (2), 722–728. <https://doi.org/10.1021/es203114q>.
- Stottmeister, U., Wiessner, A., Kusch, P., Kappelmeyer, U., Kästner, M., Bederski, O., Müller, R.A., Moormann, H., 2003. Effects of plants and microorganisms in constructed wetlands for wastewater treatment. *Biotechnol. Adv.* 22 (1–2), 93–117. <https://doi.org/10.1016/j.biotechadv.2003.08.010>.
- Uhl, M., Dittmer, U., 2005. Constructed wetlands for CSO treatment: an overview of practice and research in Germany. *Water Sci. Technol.* 51 (9), 23–30.
- Ulrich, H., Klaus, D., Irmgard, F., Annette, H., Juan, L.P., Regine, S., 2005. Microbiological investigations for sanitary assessment of wastewater treated in constructed wetlands. *Water Res.* 39 (20), 4849–4858. <https://doi.org/10.1016/j.watres.2004.07.020>.
- Vacca, G., Wand, H., Nikolausz, M., Kusch, P., Kästner, M., 2005. Effect of plants and filters in bacteria removal in pilot-scale constructed wetlands. *Water Res.* 39 (7), 1361–1373. <https://doi.org/10.1016/j.watres.2005.01.005>.
- Vymazal, J., 2005. Removal of enteric bacteria in constructed treatment wetlands with emergent macrophytes: a review. *J. Env. Sci. Health* 40 (6–7), 1355–1367. <https://doi.org/10.1081/ESE-200055851>.
- Vymazal, J., 2011. Constructed wetlands for wastewater treatment: five decades of experience. *Environ. Sci. Technol.* 45 (1), 61–69. <https://doi.org/10.1021/es101403q>.
- Vymazal, J., Kröpfelová, L., 2009. Removal of organics in constructed wetlands with horizontal sub-surface flow: a review of the field experience. *Sci. Total Environ.* 407 (13), 3911–3922. <https://doi.org/10.1016/j.scitotenv.2008.08.032>.
- WHO (2006). Guidelines for the safe use of wastewater, excreta and greywater. v. 2. Wastewater use in agriculture.
- Winward, G.P., Avery, L.M., Frazer-Williams, R., Pidou, M., Jeffrey, P., Stephenson, T., Jefferson, B., 2008. A study of the microbial quality of grey water and an evaluation of treatment technologies for reuse. *Ecol. Eng.* 32 (2), 187–197. <https://doi.org/10.1016/j.ecoleng.2007.11.001>.
- Wu, S., Carvalho, P.N., Müllerc, J.A., Manojd, V.R., Donga, R., 2016. Sanitation in constructed wetlands: a review on the removal of human pathogens and fecal indicators. *Sci. Total Environ.* 541, 8–22. <https://doi.org/10.1016/j.scitotenv.2015.09.047>.