



ELSEVIER

Available online at [www.sciencedirect.com](http://www.sciencedirect.com)

SCIENCE @ DIRECT®

Journal of Sound and Vibration 285 (2005) 721–733

JOURNAL OF  
SOUND AND  
VIBRATION

[www.elsevier.com/locate/jsvi](http://www.elsevier.com/locate/jsvi)

Short Communication

# Transverse shear deformability in the dynamics of thin-walled composite beams: consistency of different approaches

Marcelo T. Piovan\*, Víctor H. Cortínez

*Mechanical Systems Analysis Group, Universidad Tecnológica Nacional, F.R.B.B., 11 de abril, 461-8000 Bahía Blanca, Argentina*

Received 19 April 2004; received in revised form 30 September 2004; accepted 7 October 2004  
Available online 26 January 2005

---

## Abstract

The aim of this work is to describe an analysis of the transverse shear deformability in the dynamics of thin-walled composite beams. Some thin-walled-composite-beam models, which are derived by means of different approaches (principle of virtual works and principle of Hellinger–Reissner among others), show substantial discrepancies due to the employment of different constitutive equations based on the aforementioned approaches. In the following paragraphs a comparison of different schemes and hypotheses related to constitutive equations for thin-walled composite beams is performed.

© 2004 Elsevier Ltd. All rights reserved.

---

## 1. Introduction

In the last fifteen years a number of models [1–8] have been developed to describe the dynamics of thin-walled composite beams. The accuracy of these models is strongly dependent on the different underlying concepts and hypotheses used to formulate them. Thin-walled composite beam models based on hypotheses adopted by Vlasov or Bauld and Tzeng, where shear deformability is neglected, in general overpredict the frequency values in the cases of shorter beams, especially in the determination of higher modes [1,2,8]. This is also a known fact in the context of isotropic materials.

---

\*Corresponding author.

*E-mail addresses:* [mpiovan@frbb.utn.edu.ar](mailto:mpiovan@frbb.utn.edu.ar) (M.T. Piovan), [vcortine@frbb.utn.edu.ar](mailto:vcortine@frbb.utn.edu.ar) (V.H. Cortínez).

Many non-conventional effects were incorporated with the purpose to improve the accuracy of the predicted frequencies. These improvements have been validated by means of the comparison with experimental results or, at least, with extensive 2D or 3D finite element solutions.

Two of the most relevant non-conventional effects taken into account were shear deformation and rotary inertia as an extension of Timoshenko's earlier ideas for solid section beams.

However, the incorporation of these non-conventional effects, especially shear deformations, yields accurate results when the constitutive law and the methodology of derivation are conveniently adopted. The effect of shear deformability can be taken into account by employing one or more of the following concepts: (1) shear deformability due to bending, (2) shear deformability due to non-uniform torsion warping (very important in thin-walled beams with open sections), and (3) transverse shear deformability (or thickness shear effect). Wu and Sun [1] developed their model making use of the first two concepts of shear deformability. Song and Librescu [2] developed their model employing the first and third concepts of shear deformability. These authors applied the principle of virtual works (PVW) to derive the governing equations of their respective models. On the other hand, Cortínez and Piovan [8] considered all the three aspects of the shear deformability aforementioned, however they derived their model by means of the principle of Hellinger–Reissner (PHR). One of the main differences between PVW and PHR lies in the scheme for obtaining the constitutive equations in terms of stress resultants and generalized strains.

In this note, comparisons of different shear deformable thin-walled-composite-beam models and their underlying concepts are performed. The ply sequence of the constitutive models is restricted to the particular, but quite common, case of symmetric and balanced stacking sequence. From these comparisons, the model obtained by means of the PHR appears to be the most convenient from the point of view of its accuracy (at least for determining natural frequencies).

## 2. Thin-walled beam models by means of the Hellinger–Reissner principle

The PHR for a composite thin-walled beam can be expressed in the following form [8,9]:

$$\begin{aligned} & \int_L \int_S (N_{xx} \delta \varepsilon_{xx} + M_{xx} \delta \kappa_{xx} + N_{xs} \delta \gamma_{xs} + M_{xs} \delta \kappa_{xs} + N_{xn} \delta \gamma_{xn}) \, ds \, dx \\ & + \int_L \int_S \left[ e \rho \left( \frac{\partial^2 \bar{U}}{\partial t^2} \delta \bar{U} + \frac{\partial^2 \bar{V}}{\partial t^2} \delta \bar{V} + \frac{\partial^2 \bar{W}}{\partial t^2} \delta \bar{W} \right) + \frac{e^3 \rho}{12} \left( \frac{\partial^2 \phi_{xx}}{\partial t^2} \delta \phi_{xx} + \frac{\partial^2 \phi_{ss}}{\partial t^2} \delta \phi_s \right) \right] \, ds \, dx \\ & - \int_L \int_S [\bar{q}_x \delta \bar{U} + \bar{q}_s \delta \bar{V} + \bar{q}_n \delta \bar{W} + \bar{m}_x \delta \phi_{xx} + \bar{m}_s \delta \phi_{ss}] \, ds \, dx \\ & - \left[ \int_S (\bar{N}_{xx} \delta \bar{U} + \bar{M}_{xx} \delta \phi_{xx} + \bar{N}_{xs} \delta \bar{V} + \bar{M}_{xs} \delta \phi_{ss} + \bar{N}_{xn} \delta \bar{W}) \, ds \right]_{x=0}^{x=L} = 0, \end{aligned} \quad (1a)$$

$$\begin{aligned} & \int_L \int_S \left[ \left( \varepsilon_{xx} - \frac{N_{xx}}{\bar{A}_{11}} \right) \delta N_{xx} + \left( \gamma_{xs} - \frac{N_{xs}}{\bar{A}_{66}} \right) \delta N_{xs} + \left( \kappa_{xs} - \frac{M_{xs}}{\bar{D}_{66}} \right) \delta M_{xs} \right] \, ds \, dx \\ & + \int_L \int_S \left[ \left( \kappa_{xx} - \frac{M_{xx}}{\bar{D}_{11}} \right) \delta M_{xx} + \left( \gamma_{xn} - \frac{N_{xn}}{\bar{A}_{55}^{(H)}} \right) \delta N_{xn} \right] \, ds \, dx = 0. \end{aligned} \quad (1b)$$

In expressions (1),  $\rho$  is the mass density and  $e$  is the wall-thickness.  $N_{xx}, N_{xs}, M_{xx}, M_{xs}$  and  $N_{xn}$  are the shell stress resultants and  $\bar{A}_{ij}, \bar{D}_{ij}$  are elasticity constants [10].  $\varepsilon_{xx}, \gamma_{xs}, \gamma_{xn}, \kappa_{xx}$  and  $\kappa_{xs}$  are the linear shell strains.  $\bar{U}, \bar{V}, \bar{W}, \phi_x$  and  $\phi_s$  are the shell displacements in the  $x, s$  and  $n$  directions, and bending rotations about  $s$  and  $x$ , respectively (see Fig. 1(b)), which are defined in terms of the general set of displacements given by expressions (2), as shown in Ref. [8].

It should be noted that, in Eq. (1), the stress resultants and the displacements are variationally independent quantities. Expressions (1a) and (1b) represent the variational forms of the dynamic equilibrium and constitutive equations, respectively. Eq. (1a) can also be interpreted as a form of the PVW.

The displacement field can be defined in the following form [8]:

$$u_x = u_{xo}(x) - \theta_z(x) \left( \bar{Y}(s) - n \frac{dZ}{ds} \right) - \theta_y(x) \left( \bar{Z}(s) + n \frac{dY}{ds} \right) - \theta(x)\omega(s, n), \tag{2a}$$

$$u_y = u_{yc}(x) - \phi(x) \left( Z(s) + n \frac{dY}{ds} \right), \tag{2b}$$

$$u_z = u_{zc}(x) + \phi(x) \left( Y(s) - n \frac{dZ}{ds} \right), \tag{2c}$$

where  $u_{x_o}$  is the axial displacement of the cross-sectional centroid,  $u_{y_c}$  and  $u_{z_c}$  are the lateral displacements measured from cross-sectional shear-center (defined according to Vlasov). The variables  $\theta_y$  and  $\theta_z$  are bending rotations with respect to the principal axes of the cross section. The variable  $\phi$  is the torsional rotation measured from the shear-center. The variable  $\theta$  is a measure of the torsional warping along the beam. It is important to realize that in the present formulation  $\theta$  is an independent variable. Thus, this is an important difference with other thin-walled beam formulations that express the warping measure in terms of the first derivative of the torsion rotation [2,3,5,6].

In expressions (2),  $\{Y, Z\}$  ( $\{\bar{Y}, \bar{Z}\}$ ) are the coordinates of the wall mid-line measured from the shear-center (centroid). The following expression for the warping function  $\omega$  takes into account primary as well as secondary warping [8]:

$$\omega(s, n) = \omega_P(s) + \omega_s(s, n) = \int_s [r(s) + \psi(s)] ds - D_C + nl(s) \tag{3a}$$

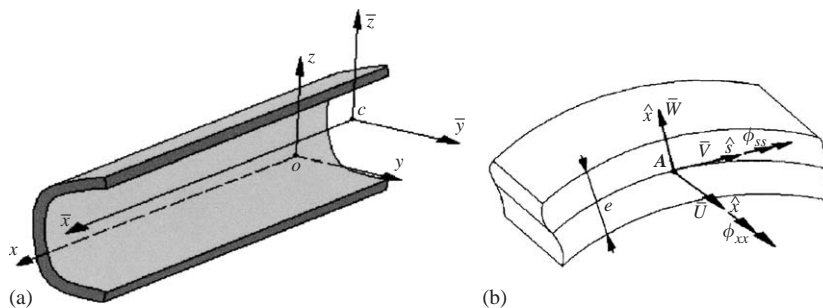

Fig. 1. Beam and coordinate system of the cross section.

with

$$\psi(s) = \frac{1}{\bar{A}_{66}(s)} \left[ \frac{\int_s r(s) ds}{\int_s \frac{1}{\bar{A}_{66}(s)} ds} \right], \quad D_C = \frac{\int_s [r(s) + \psi(s)] \bar{A}_{11}(s) ds}{\int_s \bar{A}_{11}(s) ds}, \quad (3b,c)$$

$$r(s) = Z(s) \frac{dY}{ds} - Y(s) \frac{dZ}{ds}, \quad l(s) = Y(s) \frac{dY}{ds} + Z(s) \frac{dZ}{ds}. \quad (3d,e)$$

The linear shell strains  $\varepsilon_{xx}$ ,  $\gamma_{xs}$ ,  $\gamma_{xn}$ ,  $\kappa_{xx}$  and  $\kappa_{xs}$  can be expressed in terms of generalized strains by means of the following forms [8]:

$$\varepsilon_{xx} = [\varepsilon_{D1} - Y(s)\varepsilon_{D3} - Z(s)\varepsilon_{D2} - \omega_P(s)\varepsilon_{D4}], \quad (4a)$$

$$\kappa_{xx} = \left[ \frac{dZ}{ds} \varepsilon_{D3} - \frac{dY}{ds} \varepsilon_{D2} - l(s)\varepsilon_{D4} \right], \quad (4b)$$

$$\gamma_{xs} = \left[ \frac{dY}{ds} \varepsilon_{D5} + \frac{dZ}{ds} \varepsilon_{D6} + [r(s) + \psi(s)]\varepsilon_{D7} + \psi(s)\varepsilon_{D8} \right], \quad (4c)$$

$$\gamma_{xn} = \left[ -\frac{dZ}{ds} \varepsilon_{D5} + \frac{dY}{ds} \varepsilon_{D6} + l(s)\varepsilon_{D7} \right], \quad (4d)$$

$$\kappa_{xs} = [-2\varepsilon_{D8} + \varepsilon_{D7}], \quad (4e)$$

where the generalized deformations  $\varepsilon_{D1}, \dots, \varepsilon_{D8}$  are defined as

$$\varepsilon_{D1} = \left( \frac{\partial u_{xc}}{\partial x} \right), \quad \varepsilon_{D2} = \left( \frac{\partial \theta_y}{\partial x} \right), \quad (5a,b)$$

$$\varepsilon_{D3} = \left( \frac{\partial \theta_z}{\partial x} \right), \quad \varepsilon_{D4} = \left( \frac{\partial \theta_x}{\partial x} \right), \quad (5c,d)$$

$$\varepsilon_{D5} = \left( \frac{\partial u_{yc}}{\partial x} - \theta_z \right), \quad \varepsilon_{D6} = \left( \frac{\partial u_{zc}}{\partial x} - \theta_y \right), \quad (5e,f)$$

$$\varepsilon_{D7} = \left( \frac{\partial \phi_x}{\partial x} - \theta_x \right), \quad \varepsilon_{D8} = \left( \frac{\partial \phi_x}{\partial x} \right). \quad (5g,h)$$

Actually,  $\varepsilon_{D1}$  means the longitudinal deformation,  $\varepsilon_{D2}$  and  $\varepsilon_{D3}$  are flexural curvatures,  $\varepsilon_{D4}$  is the warping deformation,  $\varepsilon_{D5}$  and  $\varepsilon_{D6}$  are related to bending shear deformation,  $\varepsilon_{D7}$  is the shear deformation related to torsion warping and  $\varepsilon_{D8}$  is related to pure torsion.

When the shell transverse strain is neglected in expression (4d) (meaning  $\gamma_{xn} = 0$ ), the remaining expressions (4) are similar to that of Wu and Sun [1]. On the other hand, imposing  $\gamma_{xn} = 0$  and  $\varepsilon_{D7} = 0$  (that is, neglecting warping shear flexibility and transverse strains), the reduced expressions (4) are identical to those employed by Smith and Chopra [11] for box beams. On the other hand, when  $\varepsilon_{D7}$  is neglected in expressions (4c) and (4d), it is possible to obtain the strain field of Song and Librescu [2,3] for box beams.

The shell stress resultants (which are consistent with shell equilibrium equations [8]) can be expressed in terms of beam stress resultants in the following form:

$$N_{xx} = e \left[ \frac{Q_X}{J_{11}} + \frac{M_Y}{J_{22}} \bar{Z} + \frac{M_Z}{J_{33}} \bar{Y} + \frac{B}{J_{44}} \omega_P \right], \tag{6a}$$

$$M_{xx} \cong \frac{e^3}{12} \left[ \frac{M_Y}{J_{22}} \frac{dY}{ds} - \frac{M_Z}{J_{33}} \frac{dZ}{ds} - \frac{B}{J_{44}} l(s) \right], \tag{6b}$$

$$M_{xs} = -\frac{e^3}{6J_{88}} T_{SV}, \tag{6c}$$

$$N_{xs} = -e \left[ \frac{Q_Z}{J_{22}} \bar{\lambda}_y(s) + \frac{Q_Y}{J_{33}} \bar{\lambda}_z(s) + \frac{T_W}{J_{44}} \bar{\lambda}_\omega(s) \right] + \frac{e\psi(s)}{J_{88}} T_{SV}, \tag{6d}$$

$$N_{xn} = \frac{e^3}{12} \left[ \frac{Q_Z}{J_{22}} \frac{dY}{ds} - \frac{Q_Y}{J_{33}} \frac{dZ}{ds} - \frac{T_W}{J_{44}} l(s) \right], \tag{6e}$$

where  $Q_X$ ,  $M_Y$ ,  $M_Z$ ,  $B$ ,  $Q_Y$ ,  $Q_Z$ ,  $T_{SV}$  and  $T_W$  are axial force, bending moment in  $y$  direction, bending moment in  $z$  direction, bimoment, shear force in  $y$  direction, shear force in  $z$  direction, pure torsion moment, flexural-torsional moment, respectively.  $J_{11}$ ,  $J_{22}$ ,  $J_{33}$ ,  $J_{44}$ , and  $J_{88}$  are cross-sectional area, inertia moments ( $z$  and  $y$  directions), warping constant and torsion constant, respectively [8]. The functions  $\bar{\lambda}_i(s)$  are expressed in the form:

$$\bar{\lambda}_y(s) = \int_0^s \bar{Z}(s) ds + \frac{\chi}{S} \oint \left[ \int_0^s \bar{Z}(s) ds \right] ds, \tag{7a}$$

$$\bar{\lambda}_z(s) = \int_0^s \bar{Y}(s) ds + \frac{\chi}{S} \oint \left[ \int_0^s \bar{Y}(s) ds \right] ds, \tag{7b}$$

$$\bar{\lambda}_\omega(s) = \int_0^s \omega_P(s) ds + \frac{\chi}{S} \oint \left[ \int_0^s \omega_P(s) ds \right] ds, \tag{7c}$$

where  $\chi$  is 0 or 1 depending on whether the cross-section contour is open or closed, respectively.  $S$  denotes the contour perimeter.

Following Refs. [8], the beam equilibrium equations can be obtained substituting Eqs. (6), (5), (4) and (2) into Eq. (1a), and the constitutive equations can be obtained substituting Eqs. (2)–(7) into Eq. (1b).

### 3. Constitutive equations and their related hypotheses

The constitutive equations of composite beams can be obtained in different ways according to the different hypotheses considered in their formulation. Some authors [4,12] have developed the constitutive equations imposing a plane stress state in the stress–strain relations of a lamina [10], and then rearranging (neglecting or replacing) hoop strains and stresses in normal and transverse

components, before obtaining the shell stress resultants and the constitutive equations of beam stress resultants in terms of generalized deformations. Other authors [1,3,6,8] based the constitutive models on imposing in the general expression (8) of shell stress resultants the conditions  $N_{ss} = N_{sn} = M_{ss} = 0$  (this is one of the most realistic hypotheses, see Refs. [10,13]) and then rearranging  $\epsilon_{ss}, \gamma_{sn}$  and  $\kappa_{ss}$  in terms of the remaining strain components.

$$\begin{pmatrix} N_{xx} \\ N_{ss} \\ N_{xs} \\ N_{sn} \\ N_{xn} \\ M_{xx} \\ M_{ss} \\ M_{xs} \end{pmatrix} = \begin{bmatrix} A_{11} & A_{12} & A_{16} & 0 & 0 & B_{11} & B_{12} & B_{16} \\ A_{12} & A_{22} & A_{26} & 0 & 0 & B_{12} & B_{22} & B_{26} \\ A_{16} & A_{16} & A_{66} & 0 & 0 & B_{16} & B_{26} & B_{66} \\ 0 & 0 & 0 & A_{44}^{(H)} & A_{45}^{(H)} & 0 & 0 & 0 \\ 0 & 0 & 0 & A_{45}^{(H)} & A_{55}^{(H)} & 0 & 0 & 0 \\ B_{11} & B_{12} & B_{16} & 0 & 0 & D_{11} & D_{12} & D_{16} \\ B_{12} & B_{22} & B_{26} & 0 & 0 & D_{12} & D_{22} & D_{26} \\ B_{16} & B_{26} & B_{66} & 0 & 0 & D_{16} & D_{26} & D_{66} \end{bmatrix} \begin{pmatrix} \epsilon_{xx} \\ \epsilon_{ss} \\ \gamma_{xs} \\ \gamma_{sn} \\ \gamma_{xn} \\ \kappa_{xx} \\ \kappa_{ss} \\ \kappa_{xs} \end{pmatrix}. \tag{8}$$

Then, following the second procedure, it is possible to obtain modified expressions of  $N_{xx}, N_{xs}, M_{xx}, M_{xs}$  and  $N_{xn}$  in terms of the strains  $\epsilon_{xx}, \gamma_{xs}, \gamma_{xn}, \kappa_{xx}$  and  $\kappa_{xs}$ . In the case of symmetric and balanced laminates, the constitutive equations take the form [8]

$$\begin{pmatrix} N_{xx} \\ N_{xs} \\ N_{xn} \\ M_{xx} \\ M_{xs} \end{pmatrix} = \begin{bmatrix} \bar{A}_{11} & 0 & 0 & 0 & 0 \\ 0 & \bar{A}_{66} & 0 & 0 & 0 \\ 0 & 0 & \bar{A}_{55}^{(H)} & 0 & 0 \\ 0 & 0 & 0 & \bar{D}_{11} & 0 \\ 0 & 0 & 0 & 0 & \bar{D}_{66} \end{bmatrix} \begin{pmatrix} \epsilon_{xx} \\ \gamma_{xs} \\ \gamma_{xn} \\ \kappa_{xx} \\ \kappa_{xs} \end{pmatrix}. \tag{9}$$

$\bar{A}_{11}, \bar{A}_{66}$ , etc. are modified elastic constants as explained in Refs. [8,14]. It has to be noted that for dynamic problems, the inclusion of  $\gamma_{xn}$  was only considered in Refs. [2,3,8]. However in Refs. [2,3] as well as in Refs. [1,6,7,12] the direct stiffness method was employed to obtain the beams stress resultants.

The beam stress resultants are defined in terms of the shell stress resultants as

$$Q_X = \int_S N_{xx} ds, \quad M_Y = \int_S \left( N_{xx} \bar{Z} + M_{xx} \frac{dY}{ds} \right) ds, \tag{10a,b}$$

$$M_Z = \int_S \left( N_{xx} \bar{Y} - M_{xx} \frac{dZ}{ds} \right) ds, \quad B = - \int_S (N_{xx} \omega_p + M_{xx} l(s)) ds, \tag{10c,d}$$

$$Q_Y = \int_S \left[ N_{xs} \frac{dY}{ds} - N_{xn} \frac{dZ}{ds} \right] ds, \quad Q_Z = \int_S \left[ N_{xs} \frac{dZ}{ds} + N_{xn} \frac{dY}{ds} \right] ds, \tag{10e,f}$$

$$T_W = \int_S \{N_{xs}[r(s) + \psi(s)] + N_{xn}l(s)\} ds, \quad T_{SV} = \int_S [N_{xs}\psi(s) - 2M_{xs}] ds. \tag{10g,h}$$

It is clear that by substituting Eq. (6) into Eq. (11), a set of identities is obtained.

### 3.1. Stiffness-based constitutive equations

The constitutive equations of the beam stress resultants in terms of the generalized deformations could be obtained substituting Eq. (9) into Eq. (10), leading to

$$\begin{pmatrix} Q_X \\ M_Y \\ M_Z \\ B \\ Q_Y \\ Q_Z \\ T_W \\ T_{SV} \end{pmatrix} = \begin{bmatrix} J_{11}^{11} & 0 & 0 & 0 & 0 & 0 & 0 & 0 \\ 0 & J_{22}^{11} & 0 & 0 & 0 & 0 & 0 & 0 \\ 0 & 0 & J_{33}^{11} & 0 & 0 & 0 & 0 & 0 \\ 0 & 0 & 0 & J_{44}^{11} & 0 & 0 & 0 & 0 \\ 0 & 0 & 0 & 0 & J_{55}^{66} & J_{56}^{66} & J_{57}^{66} & 0 \\ 0 & 0 & 0 & 0 & J_{56}^{66} & J_{66}^{66} & J_{67}^{66} & 0 \\ 0 & 0 & 0 & 0 & J_{57}^{66} & J_{67}^{66} & J_{77}^{66} & 0 \\ 0 & 0 & 0 & 0 & 0 & 0 & 0 & J_{88}^{66} \end{bmatrix} \begin{pmatrix} \varepsilon_{D1} \\ -\varepsilon_{D2} \\ -\varepsilon_{D3} \\ -\varepsilon_{D4} \\ \varepsilon_{D5} \\ \varepsilon_{D6} \\ \varepsilon_{D7} \\ \varepsilon_{D8} \end{pmatrix}, \quad (11)$$

where

$$J_{ij}^{kh} = \int_S \left( \frac{\bar{A}_{hh}}{e} \right) (\bar{g}_i^{(b)} \bar{g}_j^{(b)}) e \, ds + \int_S \left( \frac{\bar{A}_{55}^{(H)}}{e} \right) (\bar{g}_i^{(c)} \bar{g}_j^{(c)}) e \, ds + \int_S \left( \frac{12\bar{D}_{hh}}{e^3} \right) (\bar{g}_i^{(d)} \bar{g}_j^{(d)}) e^3 \, ds, \quad (12)$$

with  $\{i, j\} = \{1, \dots, 8\}$ ,  $\{h, k\} = \{1, 6\}$  and

$$\bar{g}^{(b)} = \left\{ 1, \bar{Z}(s), \bar{Y}(s), \omega_P(s), \frac{dY}{ds}, \frac{dZ}{ds}, r(s) + \psi(s), \psi(s) \right\}, \quad (13a)$$

$$\bar{g}^{(c)} = \left\{ 0, 0, 0, 0, \frac{dZ}{ds}, -\frac{dY}{ds}, -l(s), 0 \right\}, \quad \bar{g}^{(d)} = \left\{ 0, \frac{dY}{ds}, -\frac{dZ}{ds}, l(s), 0, 0, 0, -2 \right\}. \quad (13b,c)$$

In expression (14) the components of the fifth, sixth and seventh rows of Eq. (11) are shown. This is a way to understand the combination of hoop and thickness shear effects in the context of the PVW approach.

$$\begin{bmatrix} J_{55}^{66} & J_{56}^{66} & J_{57}^{66} \\ J_{56}^{66} & J_{66}^{66} & J_{67}^{66} \\ J_{57}^{66} & J_{67}^{66} & J_{77}^{66} \end{bmatrix} = \int_S \left( \frac{\bar{A}_{66}}{e} \right) \begin{bmatrix} \left( \frac{dY}{ds} \right)^2 & \frac{dZ}{ds} \frac{dY}{ds} & \frac{dY}{ds} (r + \psi) \\ \frac{dZ}{ds} \frac{dY}{ds} & \left( \frac{dZ}{ds} \right)^2 & \frac{dZ}{ds} (r + \psi) \\ \frac{dY}{ds} (r + \psi) & \frac{dZ}{ds} (r + \psi) & (r + \psi)^2 \end{bmatrix} e \, ds$$

$$+ \int_S \left( \frac{\bar{A}_{55}^{(H)}}{e} \right) \begin{bmatrix} \left( \frac{dZ}{ds} \right)^2 & -\frac{dZ}{ds} \frac{dY}{ds} & -\frac{dZ}{ds} l(s) \\ -\frac{dZ}{ds} \frac{dY}{ds} & \left( \frac{dY}{ds} \right)^2 & \frac{dY}{ds} l(s) \\ -\frac{dZ}{ds} l(s) & \frac{dY}{ds} l(s) & (l(s))^2 \end{bmatrix} e \, ds. \tag{14}$$

The first term of Eq. (14) corresponds to the shear rigidity associated with hoop strains ( $\gamma_{xs}$ ), and the second term of Eq. (14) corresponds to the shear rigidity associated with the in-thickness shear strain ( $\gamma_{xn}$ ).

### 3.2. Constitutive equations obtained by using the Hellinger–Reissner principle

In this context, the constitutive equations of beam stress resultants can be obtained by substituting Eqs. (4) and (6) into Eq. (1b). After some algebraic manipulations it is possible to arrive at the constitutive equations having form (11), but differing only in the shear components of the constitutive matrix, i.e. the elements of rows and columns 5–7. They can be calculated in the following form [8]:

$$\begin{bmatrix} J_{55}^{66} & J_{56}^{66} & J_{57}^{66} \\ J_{56}^{66} & J_{66}^{66} & J_{67}^{66} \\ J_{57}^{66} & J_{67}^{66} & J_{77}^{66} \end{bmatrix} = \left( \int_S \frac{e}{\bar{A}_{66}} \begin{bmatrix} \left( \frac{\bar{\lambda}_z}{J_{33}} \right)^2 & \left( \frac{\bar{\lambda}_z}{J_{33}} \frac{\bar{\lambda}_y}{J_{22}} \right) & -\left( \frac{\bar{\lambda}_z}{J_{33}} \frac{\bar{\lambda}_\omega}{J_{44}} \right) \\ \left( \frac{\bar{\lambda}_z}{J_{33}} \frac{\bar{\lambda}_y}{J_{22}} \right) & \left( \frac{\bar{\lambda}_y}{J_{22}} \right)^2 & -\left( \frac{\bar{\lambda}_y}{J_{22}} \frac{\bar{\lambda}_\omega}{J_{44}} \right) \\ -\left( \frac{\bar{\lambda}_z}{J_{33}} \frac{\bar{\lambda}_\omega}{J_{44}} \right) & -\left( \frac{\bar{\lambda}_y}{J_{22}} \frac{\bar{\lambda}_\omega}{J_{44}} \right) & \left( \frac{\bar{\lambda}_\omega}{J_{44}} \right)^2 \end{bmatrix} ds \right. \\ \left. + \int_S \frac{e^4}{144 \bar{A}_{55}^{(H)}} \begin{bmatrix} \left( \frac{Z_{,s}}{J_{33}} \right)^2 & \left( \frac{Z_{,s}}{J_{33}} \frac{Y_{,s}}{J_{22}} \right) & -\left( \frac{Z_{,s}}{J_{33}} \frac{\omega_{P,n}}{J_{44}} \right) \\ \left( \frac{Z_{,s}}{J_{33}} \frac{Y_{,s}}{J_{22}} \right) & \left( \frac{Y_{,s}}{J_{22}} \right)^2 & -\left( \frac{Y_{,s}}{J_{22}} \frac{\omega_{P,n}}{J_{44}} \right) \\ -\left( \frac{Z_{,s}}{J_{33}} \frac{\omega_{P,n}}{J_{44}} \right) & -\left( \frac{Y_{,s}}{J_{22}} \frac{\omega_{P,n}}{J_{44}} \right) & \left( \frac{\omega_{P,n}}{J_{44}} \right)^2 \end{bmatrix} ds \right)^{-1}, \tag{15}$$

where the following notation is used:

$$Z_{,s} = \left( \frac{dZ}{ds} \right), \quad Y_{,s} = \left( \frac{dY}{ds} \right), \quad \omega_{P,n} = \left( \frac{d\omega_P}{dn} \right). \tag{16a,b,c}$$



#### 4. Finite element analysis

In order to perform the comparative analysis of PVW and PHR approaches, a finite element scheme based on a previous work [14] of the authors is employed. In this scheme a two-node seven-degree-of-freedom element is used. It is possible to neglect different terms of shear flexibility within the element basis. Also, a Vlasov-type element may be obtained as a limit case when the rotary inertia terms and the shear flexibility are completely neglected (i.e.  $\varepsilon_{D5} = \varepsilon_{D6} = \varepsilon_{D7} = 0$ ).

As a first example, in Fig. 2, the cross section of a simply supported U-beam made of graphite–epoxy AS4/3506-1 and the corresponding stacking sequence and slenderness ratio are shown. In Table 1, a comparison is shown for the first four flexural-torsional frequencies obtained with the Vlasov model, the PVW approach and the PHR approach. The frequencies of the shear flexible models (PVW and PHR) were obtained considering only  $\gamma_{xs}$  and neglecting  $\gamma_{xn}$ . In Table 2 the same frequencies are shown, but now taking into account  $\gamma_{xs}$  and  $\gamma_{xn}$ .

It can be seen in Tables 1 and 2 that the Vlasov model overestimates the frequency values with respect to the predictions of the shear flexible approaches. There are, however, some discrepancies between the frequencies obtained by the different shear deformable models (PVW and PHR).

The aforementioned discrepancy is increased with the increase of the ratio  $e/h$  and the frequency order. When using the PHR approach, the frequency values obtained by considering both  $\gamma_{xs}$  and  $\gamma_{xn}$  are lower than those corresponding to the case that neglects  $\gamma_{xn}$ . This last behaviour appears to be reasonable. In fact, when the beam is more flexible ( $\gamma_{xs} \neq 0$  and  $\gamma_{xn} \neq 0$ ) its frequencies are lower. However, the opposite occurs when the PVW approach is used. That is, frequencies increase for the more flexible case ( $\gamma_{xs} \neq 0$  and  $\gamma_{xn} \neq 0$ ). This is a non-consistent behaviour. Therefore, when applying the PVW approach it appears to be more consistent to neglect  $\gamma_{xn}$ .

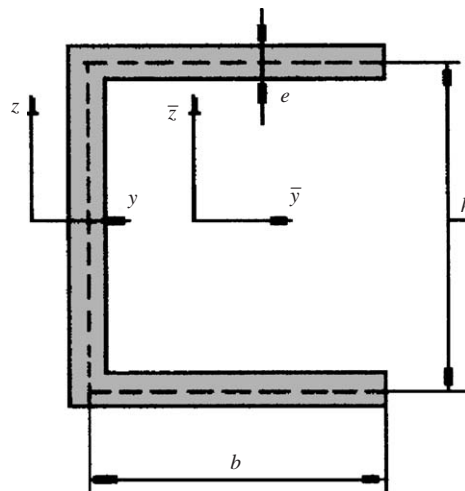

Fig. 2. Cross section of a composite U-beam and its properties. Composite material is AS4/3506-1:  $E_1 = 144$  GPa,  $E_2 = 9.68$  GPa,  $G_{12} = G_{13} = 4.14$  GPa,  $G_{23} = 3.45$  GPa,  $\nu_{12} = 0.3$ ,  $\nu_{23} = 0.5$ ,  $\rho = 1389$  kg/m<sup>3</sup>,  $h/L = 0.1$ ;  $\{h, b, e\} = \{0.6, 0.6, 0.03\}$  m. Stacking sequence of each segment:  $\{15/-15/-15/15\}$ . Boundary conditions: simply supported at both ends.

Table 1

Flexural-torsional frequencies (Hz) of a simply supported U-beam considering only  $\gamma_{xs}$  in the shear flexible constitutive model

$e/h$	Approach	$f_1$	$f_2$	$f_3$	$f_4$
0.05	[I]	36.36	139.63	187.20	311.74
	[II]	35.01	121.74	140.07	238.06
	[III]	34.78	119.08	137.61	229.22
0.10	[I]	41.27	145.16	189.92	317.32
	[II]	39.83	127.34	142.44	244.09
	[III]	39.62	124.85	141.36	235.66
0.15	[I]	47.92	153.77	194.38	326.30
	[II]	45.94	135.47	149.04	253.12
	[III]	45.76	133.24	147.55	245.41

[I] Vlasov-model, [II] PVW approach, [III] PHR approach.

Table 2

Flexural-torsional frequencies (Hz) of a simply supported U-beam considering  $\gamma_{xs}$  and  $\gamma_{xn}$  in the shear flexible constitutive model

$e/h$	Approach	$f_1$	$f_2$	$f_3$	$f_4$
0.05	[I]	36.36	139.63	187.20	311.74
	[II]	35.58	128.96	143.10	264.46
	[III]	34.78	119.08	137.61	229.19
0.10	[I]	41.27	145.16	189.92	317.32
	[II]	40.41	134.53	146.30	270.35
	[III]	39.62	124.77	141.34	235.42
0.15	[I]	47.92	153.77	194.38	326.30
	[II]	46.59	142.68	151.76	279.35
	[III]	45.73	132.92	147.46	244.28

[I] Vlasov-model, [II] PVW approach, [III] PHR approach.

A cantilever C-beam with its geometrical and material properties is depicted in Fig. 3. This beam was tested experimentally in order to assess the efficiency of early shear-deformable thin-walled-composite-beam models [1]. In Table 3 comparisons of the present approaches with experimental and computational results are depicted. It is possible to see that the PHR approach, when  $\gamma_{xn}$  and  $\gamma_{xs}$  are considered, leads to frequency predictions closer to the experimental values.

As it can be seen, the use of shear-flexible models by means of PVW (or the direct stiffness method) considering in-thickness shear deformability (i.e.  $\gamma_{xn}$ ) leads to a non-consistent over-prediction of the frequency values. Conversely, the use of hoop and thickness shear flexibility in the PHR approach leads to consistent and more realistic values of the frequencies. This behaviour can be explained recalling the derivation methodologies of constitutive equations for PVW and

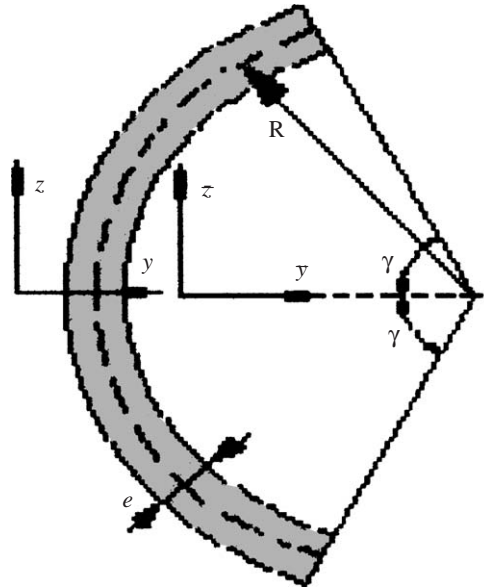

Fig. 3. Cross section of a composite C-beam and its properties. Composite material is epoxy plastic reinforced with graphite:  $E_1 = 128$  GPa,  $E_2 = 11$  GPa,  $G_{12} = 4.48$  GPa,  $\nu_{12} = 0.25$ ,  $\rho = 1500$  kg/m<sup>3</sup>,  $L = 0.152$  m. Stacking sequence:  $\{0/\pm 45/90\}_s$ . Boundary conditions: clamped at  $x = 0$ , free at  $x = L$ .  $R = 0.127$  m,  $\gamma = 17.14^\circ$ ,  $e = 1.04$  mm.

Table 3

First three frequencies (Hz) of a cantilever composite cylindrical panel with quasi-isotropic stacking sequence  $\{0/\pm 45/90\}_s$

Reference and solution approach	$f_1$	$f_2$	$f_3$
Type of mode	1°FT	1°F	2°FT
Wu–Sun [1] shear deformable beam solution	194.10	235.80	724.10
Experiment of Crawley [1]	<b>177.00</b>	<b>201.80</b>	<b>645.00</b>
Present PHR approach ( $\gamma_{xn} \neq 0$ )	<b>178.84</b>	<b>227.11</b>	<b>616.03</b>
Present PHR approach ( $\gamma_{xn} = 0$ )	178.84	227.80	616.73
Present PVW approach ( $\gamma_{xn} \neq 0$ )	196.40	240.40	746.10
Present PVW approach ( $\gamma_{xn} = 0$ )	187.40	235.00	668.60

1°FT means first flexural-torsional, 1°F means first flexural and 2°FT means second flexural-torsional.

PHR approaches. Then, comparing expressions (14) and (15), that is the shear components of constitutive equations of the PVW and PHR approaches, respectively, the difference between the constitutive models can be clearly identified. In expression (14) the consideration of  $\gamma_{xn}$  leads to the direct addition of rigidity terms, whose effect is to increase the frequency values. Contrary, in expression (15) the consideration of  $\gamma_{xn}$  does not add rigidity, instead it implies the addition of flexibility, which is in fact closer to the idea of including a non-conventional flexibility effect in a beam model.

## 5. Conclusions

In this note a comparison of different schemes and hypotheses related to constitutive equations for thin-walled composite beams was performed. The role of the in-thickness shear deformation  $\gamma_{xn}$  was focused on and studied by the use of experimental results. It was shown that the consideration of  $\gamma_{xs}$  and  $\gamma_{xn}$  in beam models based on the PVW leads to an over prediction of the frequency values, in comparison with the results obtained taking into account only  $\gamma_{xs}$ . The employment of Reissner's methodology can overcome this problem, leading to consistent frequency values. However, the PVW approach can reach acceptable results when the in-thickness shear strain  $\gamma_{xn}$  is neglected.

This circumstance is remarkable, important in the vibration of thin-walled beams with general lamination, where PHR approaches are not yet available due to their inherent complex formulation. However, as a first approximation, PVW approaches (considering only hoop shear flexibility) may be employed in the determination of the lower frequencies.

## Acknowledgements

The support of Secretaría de Ciencia y Tecnología, Universidad Tecnológica Nacional and CONICET is greatly recognized.

## References

- [1] X.X. Wu, C.T. Sun, Vibration analysis of laminated composite thin walled beams using finite elements, *AIAA Journal* 29 (5) (1990) 736–742.
- [2] O. Song, L. Librescu, Free vibration of anisotropic composite thin-walled beams of closed cross-section contour, *Journal of Sound and Vibration* 167 (1) (1993) 129–147.
- [3] O. Song, L. Librescu, Structural modeling and free vibration analysis of rotating composite thin-walled beams, *Journal of American Helicopter Society* 42 (4) (1997).
- [4] O. Rand, Fundamental closed-form solutions for solid and thin-walled composite beams including a complete out-of-plane warping model, *International Journal Solids and Structures* 35 (21) (1998) 2775–2793.
- [5] R. Chandra, I. Chopra, Experimental and theoretical analysis of composite I-beams with elastic couplings, *AIAA Journal* 29 (1991) 2197–2206.
- [6] R. Chandra, A.D. Stemple, I. Chopra, Thin-walled composite beams under bending torsional and extensional loads, *Journal of Aircraft* 27 (1990) 619–626.
- [7] W.H. Prosser, M.R. Gorman, J. Dorigi, Extensional and flexural waves in a thin-walled graphite/epoxy tube, *Journal of Composite Materials* 26 (14) (1992) 418–427.
- [8] V.H. Cortínez, M.T. Piovan, Vibration and buckling of composite thin-walled beams with shear deformability, *Journal of Sound and Vibration* 258 (4) (2002) 701–723.
- [9] K. Washizu, *Variational Methods in Elasticity and Plasticity*, Pergamon Press, Oxford, 1968.
- [10] E.J. Barbero, *Introduction to Composite Material Design*, Taylor and Francis, London, 1999.
- [11] E.C. Smith, I. Chopra, Formulation and evaluation of an analytical model for composite box-beams, *Journal of American Helicopter Society* 36 (3) (1991) 23–35.
- [12] C. Kim, S.R. White, Thick-walled composite beam theory including 3D elastic effects and torsional warping, *International Journal Solids and Structures* 34 (31,32) (1997) 4237–4259.

- [13] M.T. Piovan, Estudio Teórico y Computational Sobre la Mecánica de Vigas Curvas de Materiales Compuestos, Con Sección de Paredes Delgadas Considerando Efectos no Convencionales, Doctoral Dissertation, Universidad Nacional del Sur, 2003.
- [14] M.T. Piovan, V.H. Cortínez, S. Machado, Forced vibration of shear deformable composite thin-walled beams, *Applied Mechanics in the Americas* 9 (2002) 601–604.