



Contents lists available at ScienceDirect

Journal of Hazardous Materials

journal homepage: www.elsevier.com/locate/jhazmat



Factorial design optimization of experimental variables in the on-line separation/preconcentration of copper in water samples using solid phase extraction and ICP-OES determination

Luis A. Escudero^{a,b}, S. Cerutti^{a,b}, R.A. Olsina^{a,b}, J.A. Salonia^a, J.A. Gasquez^{a,*}

^a Área de Química Analítica, Departamento de Química, Facultad de Química, Bioquímica y Farmacia, Universidad Nacional de San Luis, Chacabuco 917, CP D5700BWS, San Luis, Argentina

^b Consejo Nacional de Investigaciones Científicas y Técnicas (CONICET), Av. Rivadavia 1917, CP C1033 AAJ, Capital Federal, Buenos Aires, Argentina

ARTICLE INFO

Article history:

Received 13 May 2010

Accepted 2 July 2010

Available online xxx

Keywords:

Copper determination

On-line preconcentration

ICP-OES

Ethyl vinyl acetate

ABSTRACT

An on-line preconcentration procedure using solid phase extraction (SPE) for the determination of copper in different water samples by inductively coupled plasma optical emission spectrometry (ICP-OES) is proposed. The copper was retained on a minicolumn filled with ethyl vinyl acetate (EVA) at pH 8.0 without using any complexing reagent. The experimental optimization step was performed using a two-level full factorial design. The results showed that pH, sample loading flow rate, and their interaction (at the tested levels) were statistically significant. In order to determine the best conditions for preconcentration and determination of copper, a final optimization of the significant factors was carried out using a central composite design (CCD). The calibration graph was linear with a regression coefficient of 0.995 at levels near the detection limit up to at least $300 \mu\text{g L}^{-1}$. An enrichment factor (EF) of 54 with a preconcentration time of 187.5 s was obtained. The limit of detection (3σ) was $0.26 \mu\text{g L}^{-1}$. The sampling frequency for the developed methodology was about 15 samples/h. The relative standard deviation (RSD) for six replicates containing $50 \mu\text{g L}^{-1}$ of copper was 3.76%. The methodology was successfully applied to the determination of Cu in tap, mineral, river water samples, and in a certified VKI standard reference material.

© 2010 Elsevier B.V. All rights reserved.

1. Introduction

The essential trace elements are necessary for growth, normal physiological functioning, and maintaining of life. However, the ingestion or inhalation of large doses may lead to toxic effects. Trace metals are ubiquitous environmental contaminants and they can be easily taken up by humans, animals, plants, and waters in the environment [1].

Copper is an essential trace element and adverse health effects can potentially be associated with both very low and very high intakes [1]. Human long-term exposure to copper can cause acute gastrointestinal effects. These include stomachaches, dizziness, vomiting and diarrhea [2]. Intentionally high uptakes of copper may cause liver and kidney damage and even death. Whether copper is carcinogenic has not been determined yet. Accurate estimates of inhalation and ingestion (food and drinking water) exposures are therefore needed in order to realistically assess any effects of the distribution of copper intakes. Because the Cu concentration levels are very low in water samples, sensitive analytical techniques are

required to obtain low detection limits. Nevertheless, the cost of the instrumentation of the inductively coupled plasma mass spectrometry (ICP-MS) may be prohibitive to many laboratories or the detection capability of the technique inductively coupled plasma optical emission spectroscopy (ICP-OES), flame atomic absorption spectroscopy (FAAS) or electrothermal atomic absorption spectrometry (ETAAS) is not sufficient when the metal concentrations are too low. In order to overcome these difficulties, enrichment-separation approaches including solvent extraction, cloud point extraction (CPE), solid phase extraction (SPE), co-precipitation, etc. have been commonly used to improve the instrumental limits of detection [3–35]. In this sense, solid phase extraction procedures using minicolumns filled with sorbent materials have a very important role in preconcentration studies due to their simplicity, high enrichment factors, environmental friendliness, etc. However, one of the challenging and time-consuming steps with such minicolumn preconcentration techniques have been the optimization of the several factors that affect the extraction procedure. In most cases, a classical one-at-a-time approach is applied, which may result in wrong conclusions if there are some interactions among the different factors [36].

In the recent years multivariate techniques have been used for optimization of analytical methods. These techniques allow more

* Corresponding author. Tel.: +54 2652 425385; fax: +54 2652 430224.

E-mail address: jgasquez@unsl.edu.ar (J.A. Gasquez).

Table 1
ICP-OES instrumental parameters.

RF generator power plasma	0.8 kW
Frequency of RF generator	40.68 MHz
Gas flow rate	8.5 L min ⁻¹
Auxiliary gas flow rate	1.0 L min ⁻¹
Observation height (above load coil)	15 mm
Wavelength	324.754 nm

than one variable to be optimized simultaneously and have several advantages, such as speed of analysis, practicality, economy, and reduction in the number of experiments that need to be carried out [37–42]. In addition, these methods are able to generate mathematical models that permit estimate the relevance as well as statistical significance of the factors' effects on the processes and also evaluate the interactions' effects among the factors. Factorial design is one of the available statistical processes for multivariate optimization and is widely applied in chemistry due to its usefulness in the identification of the significant variables and the best conditions of an experiment. However, in order to determine the real functionality established among the analytical response and the significant factors, second order designs are used.

Our research group had previously reported the use of materials for solid phase extraction, minicolumns packed with ethyl vinyl acetate (EVA) were used for As [43], Mo [44], Se and Te [45] preconcentrations with suitable results. EVA, due to its properties of chemical resistance and long-term lifetime, does not need any regeneration or repacking and remains unaltered after the preconcentration or elution step.

In this work, a preconcentration procedure using solid phase extraction for the determination of copper in water samples by ICP-OES is proposed. The extraction and preconcentration steps were performed using a minicolumn of EVA and filled with the same material. A two-level full factorial design was used to evaluate the experimental variables including pH, sample loading flow rate, and eluent concentration. The experiments for the optimization were performed according to the central composite response surface experimental design. To the best of our knowledge, this is the first time that EVA and the optimized preconcentration methodology are proposed for Cu determination. In addition, this study offers a simple system with no need of any complexing agent or chemical modifier.

2. Experimental

2.1. Instrumentation

The measurements were performed with a Model ICP 2070 sequential spectrometer (BAIRD, Bedford, MA, USA). The 1 m Czerny-Turner monochromator had a holographic grating with 1800 mm⁻¹ groove. The operating conditions of the ICP-OES equipment are listed in Table 1.

The pH was determined using a portable pH-meter (Orion Research, Inc., Orion 230 A, Beverly, MA, USA) equipped with a 9107 BN Orion glass electrode. The minicolumn used was prepared using turnings small particles of spiraled shape cross-linked EVA.

The Minipuls™ 2 peristaltic pumps (Gilson, Villiers le Bel, France) were used. The sample injection was achieved using a Reodhyne® (Cotati, CA, USA) model 50 four-way rotary valve.

2.2. Reagents and solutions

All chemicals used in this work were of analytical reagent grade and were used without further purification. Ultrapure water with a maximum resistivity of 18.2 MΩ cm was obtained from an EASY pure RF (Barnstead, Dubuque, IA, USA) was used for all dilutions.

All the plastic and glassware materials were cleaned by soaking in diluted HNO₃ (1 + 9) and were rinsed with distilled water prior to use.

Working standard solutions of the metal were prepared by dilution of a 1000 mg L⁻¹ Cu(II) atomic spectroscopy standard solution Trace CERT® (Fluka, Buchs, Switzerland).

Hydrochloric acid, puriss. p.a. ACS (Sigma–Aldrich), was used as eluent in the flow injection system and prepared by appropriate dilution with distilled water from the concentrated acid.

Buffer solution was prepared from sodium tetraborate puriss p.a. standard substance (Riedel-de Haën, Seelze, Germany) adjusted to the appropriate pH (8.00) by adding diluted hydrochloric acid or sodium hydroxide solution. Fresh buffer solution was prepared daily.

2.3. Column preparation

EVA is a flexible (rubbery), transparent polymeric material with good low temperature flexibility, good chemical resistance (to acids, alkalis, and alcohols), and high friction coefficient. This material was employed to make the preconcentration minicolumn as follows: the minicolumn was prepared by placing 100 mg approximately of EVA turnings (small shavings with a media length of 1.5 mm and a media wide of 0.45 mm) into an empty cylindrical EVA tubing (85 mm long and 4.0 mm i.d.) using the dry packing method. Further increase in minicolumn length generated elution tails without improving the analytical response. Small amount of quartz wool was placed on both ends of the minicolumn. Finally, the column was connected with a PTFE tubing to the peristaltic pump to form the preconcentration system. This minicolumn was used for around 1000 cycles and the retention capacity did not change.

2.4. Sample preparation and on-line preconcentration system for copper determination

Immediately after collection, the natural water samples were filtered using 0.45 μm pore diameter membrane filters. After that, the water samples were acidified to pH 2 with nitric acid and stored in plastic containers at 4 °C.

A diagram of the on-line preconcentration system is shown in Fig. 1. As illustrated, the flow system consisted of two peristaltic pumps (P₁ and P₂) fitted with Tygon tubes, a four-way valve (V), and a minicolumn (MC) packed with EVA coupled to the ICP-OES. The flow system was operated in a time-based mode. A 50 μg L⁻¹ copper sample (S) and a sodium tetraborate solution (B) were pumped at 8 and 2.5 mL min⁻¹, respectively through the minicolumn where the analyte was retained. The remaining solution was discharged (W). When the injection valve was switched, a stream of 1 mol L⁻¹ hydrochloric acid (E) flowing at 1.5 mL min⁻¹ eluted the copper retained. The eluate was taken directly into the nebulizer system of the ICP-OES and the analytical response was recorded as the peak height.

2.5. Optimization strategy

The optimization process was carried using a two-level full factorial design and a central composite design (CCD) involving three and two variables, respectively. All the experiments were carried out in duplicates using a 50 μg L⁻¹ copper solution. Three variables: pH of buffer solution, sampling flow rate, and eluent concentration were considered as factors. The experimental data was processed by using the MINITAB® computer software [46].

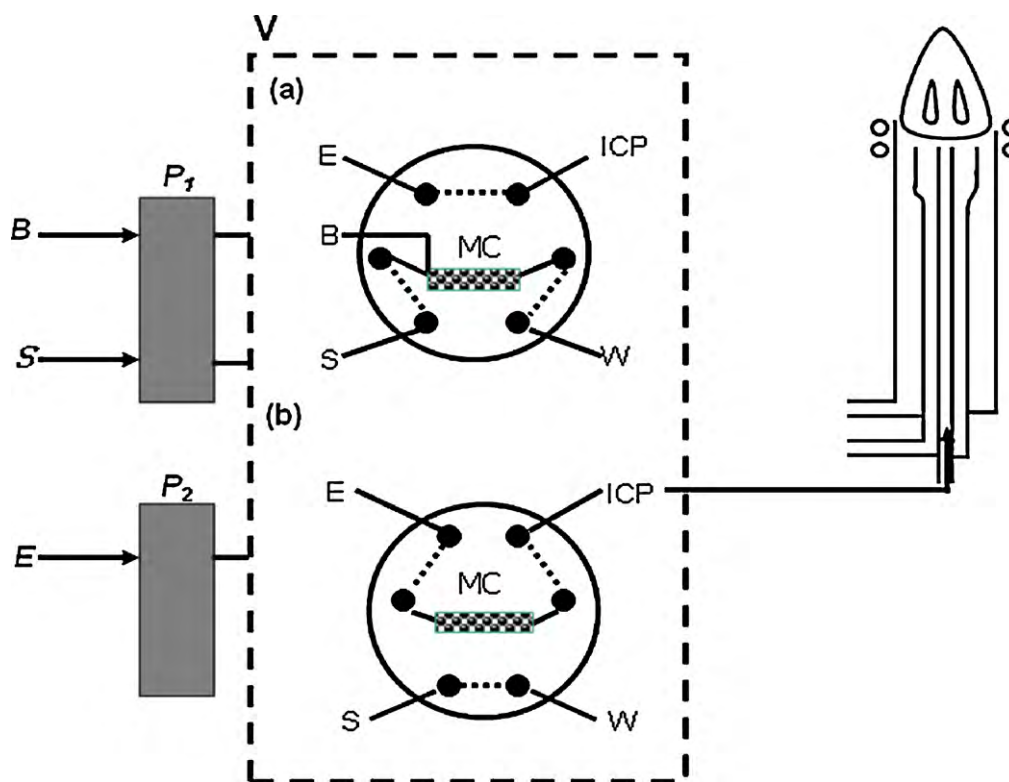

Fig. 1. Schematic diagram of the instrumental setup. S: sample (flow rate: 8.0 mL min⁻¹); B: buffer solution (flow rate 2.5 mL min⁻¹); E: eluent (flow rate 1.5 mL min⁻¹); W: waste; P₁, P₂: peristaltic pump; MC: minicolumn; V: injection valve. Valve positions: (a) sample loading; (b) injection.

3. Results and discussions

3.1. Factorial design

Preliminary tests were performed to investigate the factors that could influence the Cu retention on the EVA minicolumn. In this sense, the effect of the pH value on the system under study was very important for Cu recovery. The influence of the pH on the retention behavior of copper was studied from 1 to 12. A quantitative recovery (>95%) could be obtained at pH values between 5.5 and 8.5. In addition, sampling flow rate (previously evaluated between 1.0 and 10 mL min⁻¹) and eluent concentration (tested between 0.1 and 2.5 mol L⁻¹) also showed an important effect on copper retention.

Therefore, in order to determine the influence of these factors and their interactions on the system, a two-level full factorial, 2³ for 8 runs (in duplicate), design was performed. Minimum, maximum, and central point levels of each factor (Table 2) were chosen according to the data from previous experiments. Table 3 shows the experimental design and the respective relative analytical signal. Analysis of variance (ANOVA) and *p*-value were used to evaluate the significance of the effects on the preconcentration system, main effects and their interactions can be seen in the Pareto chart shown in Fig. 2. The interpretation of the factorial design by the Pareto chart demonstrated that sampling flow rate and pH were

Table 2
Factors and level used in the 2³ factorial design.

Variable	Low (-)	Central point (0)	High (+)
Flow rate sample (mL min ⁻¹)	2	5	8
pH	4	6	8
Eluent concentration (mol L ⁻¹)	0.7	1.5	2

statistically significant at the 95% confidence level. The eluent concentration showed poor influence and was fixed at 1 mol L⁻¹ in order to decrease reagent consumption.

3.2. Final optimization using a central composite design

Results of the factorial design demonstrated that the variables (pH and sampling flow rate) at the studied levels required a final optimization. Thus, a CCD involving them was developed for such

Table 3
Design matrix and the results of the factorial design (*n* = 3).

Experiment	pH	Sample flow rate	Eluent concentration	Relative analytical signal (%) ^a
1	-	-	-	13.66
2	+	-	-	23.60
3	-	+	-	39.13
4	+	+	-	95.65
5	-	-	+	17.39
6	+	-	+	22.36
7	-	+	+	35.40
8	+	+	+	100.00
9	-	-	-	13.04
10	+	-	-	23.60
11	-	+	-	35.40
12	+	+	-	91.93
13	-	-	+	13.66
14	+	-	+	25.47
15	-	+	+	33.54
16	+	+	+	95.03
17	0	0	0	55.28
18	0	0	0	50.93
19	0	0	0	46.58

^a Analytical signal resulted from the instrumental peak height measurements. Once these values were obtained, the highest one was considered the 100 (Experiment 8) and the others as a percentage of this maximum (relative analytical signal (%)).

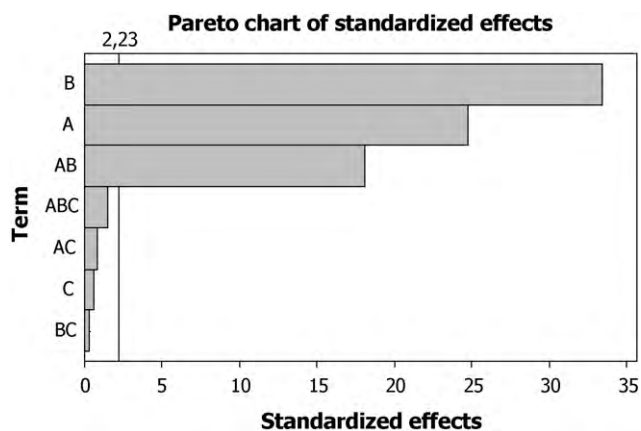

Fig. 2. Pareto chart of standardized effects for variables related to copper solid phase extraction. (A) pH; (B) sample flow rate (mL min⁻¹); (C) eluent concentration.

Table 4
Central composite design used to obtain the response surface.

Experiment	Sample flow rate (mL min ⁻¹)	pH	Relative analytical signal (%) ^a
1	7.00	7.00	68.64
2	9.00	7.00	69.82
3	7.00	9.00	81.66
4	9.00	9.00	85.80
5	6.59	8.00	79.29
6	9.41	8.00	87.57
7	8.00	6.59	74.56
8	8.00	9.41	94.08
9	8.00	8.00	100.00
10	8.00	8.00	99.41
11	8.00	8.00	100.00
12	8.00	8.00	91.72
13	8.00	8.00	90.53

^a Analytical signal resulted from the instrumental peak height measurements. Once these values were obtained, the highest one was considered the 100 (Experiment 9) and the others as a percentage of this maximum (relative analytical signal (%)).

purpose. The experiment required by CCD was a cube central with five central points in cube and four axial points; this is detailed in Table 4. The sampling flow rate varied from 6.6 to 9.4 mL min⁻¹ and the pH from 6.6 to 9.4. The CCD data was used to create the surface response showed in Fig. 3, which is described by a quadratic equation (Eq. (1)), where *A* represents the pH, *B* the sample flow

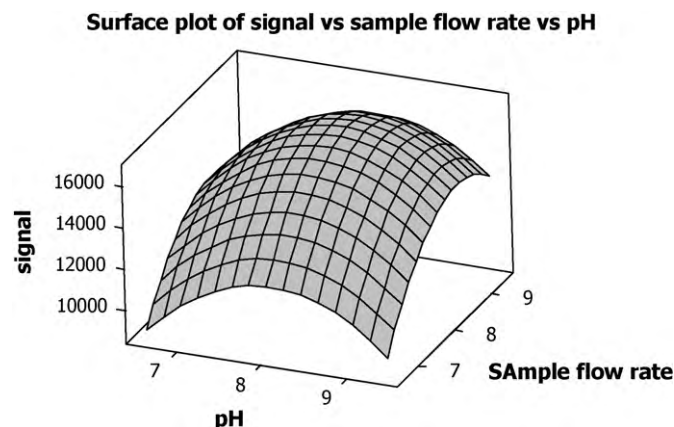

Fig. 3. Response surface obtained using central composite design.

Table 5
Analytical results for the application of the proposed methodology in natural water samples and standard reference material.

Sample	µg L ⁻¹			
	Found	Added	Sum	Recovery (%) ^a
Tap water	5.44	0.00	5.44	–
		5.00	10.49	101.00
		10.00	15.33	98.90
		20.00	25.29	99.25
Mineral water	3.94	0.00	3.94	–
		5.00	8.92	99.60
		10.00	13.90	99.60
		20.00	23.98	100.20
River water ^b	5.67	0.00	5.67	–
		5.00	10.60	98.60
		10.00	15.69	100.20
		20.00	25.59	99.60
River water ^c	3.05	0.00	3.05	–
		5.00	7.99	98.90
		10.00	13.09	100.40
		20.00	22.98	99.65
QC METAL LL1	20.88 ± 1.08	0.00	20.88 ± 1.08	–

^a Recovery (%) = [(found – base)/added] × 100.
^b Potrero river water.
^c Valle of Pancanta river water.

rate, and *A* × *A*, *B* × *B*, and *A* × *B* their interactions.

$$Y = -1.62 \times 10^{-5} + 21799.98 \times B + 21435.86 \times A - 1402.5(A \times A) - 1327.5(B \times B) + 124.0(A \times B) \quad (1)$$

From the CCD study the optimal conditions to obtain a maximum analytical signal value were attained. Thus a sample flow rate of 8 mL min⁻¹ and a pH of 8 were used for further experiments.

3.3. Interferences studies

In order to assess the effects of common coexisting ions, which could interfere with the determination of Cu, several analytes were tested at the concentration levels at which they may occur in the sample concerned. The tolerance limits of the coexisting ions, defined as the largest amount of ion that produces a recovery of Cu less than 90%, were evaluated. The results showed that Zn(II), Cd(II), Ni(II), Co(II), Cr(III), Mn(II), Al(III), Fe(III) could be tolerated up to at least 2500 µg L⁻¹. Other common matrix components such as alkaline and alkaline-earth elements were not retained on the minicolumn.

3.4. Figures of merit

The calibration curve obtained resulted to be experimentally linear up to at least 300 µg L⁻¹. The correlation coefficient was 0.995. The limit of detection LOD was calculated as 3σ/S; where *S* is the slope of the calibration curve and σ is the standard deviation of six consecutive measurements of the blank solution. The LOD value was 0.26 µg L⁻¹. The precision of a 50 µg L⁻¹ copper solution, calculated as the relative standard deviation (RSD) of six consecutive measurements, was 3.76%.

The overall time required for preconcentration of 25 mL of sample was 187.5 s (flow rate of 8 mL min⁻¹), elution (30 s, at flow rate of 1.5 mL min⁻¹), and washing and conditioning (30 s) was about 4.1 min; hence, the throughput sample was approximately 15 samples/h. The enrichment factor calculated as the ratio of the slope of the calibration graph with and without preconcentration was 54.

The accuracy of the proposed method was investigated by analyzing a VKI QC METAL LL1 standard reference material with a copper concentration of $21.10 \pm 1.06 \mu\text{g L}^{-1}$. A good agreement with the certified value was achieved (Table 5).

3.5. Application in water samples

Using the preconcentration methodology, tests of addition/recovery were performed (Table 5). Good agreements for copper concentration levels were obtained between spiked and measured analyte amounts. The recovery values calculated from the spiked standards were higher than 95% for all the cases. In the light of these results, the proposed solid phase extraction procedure could be applied for analysis of these samples satisfactorily.

4. Conclusion

Application of two-level full factorial and central composite designs allowed the efficient optimization of the variables involved in the solid phase extraction EVA-based procedure for the preconcentration of copper in water samples using ICP-OES detection.

This methodology showed to be a suitable in order to improve the sensitivity of ICP-OES for Cu determination. The proposed system was simple, rapid, and user-friendly for the determination of Cu in water samples. Analytical features, such as enrichment factor, limit of detection, and accuracy were satisfactory and comparable to other methods reported in the literature.

Acknowledgements

The authors acknowledge the financial support of the Universidad Nacional de San Luis (UNSL-San Luis, Argentina), Consejo Nacional de Investigaciones Científicas y Técnicas (CONICET, Argentina), and Agencia Nacional de Promoción Científica y Tecnológica-Fondo Nacional para Ciencia y Tecnología (FONCYT, Argentina).

References

- [1] M.J. Yonone-Lioy, P.J. Lioy, Assessment of human exposure to copper: a case study using the NHEXAS database, *J. Expo. Sci. Environ. Epidemiol.* 16 (2006) 397–409.
- [2] G.E. Lagos, L.C. Maggi, D. Peters, F. Reveco, Model for estimation of human exposure to copper in drinking water, *Sci. Total Environ.* 239 (1999) 49–70.
- [3] B. Feist, B. Mikula, K. Pytlakowska, B. Puzio, F. Buhl, Determination of heavy metals by ICP-OES and F-AAS after preconcentration with 2,2-bipyridyl and erythrosine, *J. Hazard. Mater.* 152 (2008) 1122–1129.
- [4] M. Faraji, Y. Yamini, S. Shariati, Application of cotton as a solid phase extraction sorbent for on-line preconcentration of copper in water samples prior to inductively coupled plasma optical emission spectrometry determination, *J. Hazard. Mater.* 166 (2009) 1383–1388.
- [5] J.S. Suleiman, H. Bin, H. Peng, C. Huang, Separation/preconcentration of trace amounts of Cr, Cu and Pb in environmental samples by magnetic solid-phase extraction with Bismuthiol-II-immobilized magnetic nanoparticles and their determination by ICP-OES, *Talanta* 77 (2009) 1579–1583.
- [6] E.L. Silva, P.d.S. Roldan, M.F. Giné, Simultaneous preconcentration of copper, zinc, cadmium, and nickel in water samples by cloud point extraction using 4-(2-pyridylazo)-resorcinol and their determination by inductively coupled plasma optical emission spectrometry, *J. Hazard. Mater.* 171 (2009) 1133–1138.
- [7] V.K. Jain, C. Hire, Mandalia, S. Hrishikesh, Disha Gupta, J. Vyas, Azocalix [4]pyrrole Amberlite XAD-2: new polymeric chelating resins for the extraction, preconcentration and sequential separation of Cu(II), Zn(II) and Cd(II) in natural water samples, *Talanta* 79 (2009) 1331–1340.
- [8] C.K. Su, T.W. Li, Y.C. Sun, Online in-tube solid-phase extraction using a nonfunctionalized PVC tube coupled with ICPMS for in vivo monitoring of trace metals in rat brain microdialysates, *Anal. Chem.* 80 (2008) 6959–6967.
- [9] F. Xie, X. Lin, X. Wu, Z. Xie, Solid phase extraction of lead (II), copper (II), cadmium (II) and nickel (II) using gallic acid-modified silica gel prior to determination by flame atomic absorption spectrometry, *Talanta* 74 (2008) 836–843.
- [10] N. Satrioglu, C. Arpa, Cloud point extraction for the determination of trace copper in water samples by flame atomic absorption spectrometry, *Microchim. Acta* 162 (2008) 107–112.
- [11] M. Ghaedi, A. Shokrollahi, A.H. Kianfar, A. Pourfarokhi, N. Khanjari, A.S. Mirsadeghi, M. Soylak, Preconcentration and separation of trace amount of heavy metal ions on bis(2-hydroxy acetophenone)ethylenimine loaded on activated carbon, *J. Hazard. Mater.* 162 (2009) 1408–1414.
- [12] M.A. Farajzadeh, M. Bahrām, S. Zorita, B.G. Mehr, Optimization and application of homogeneous liquid–liquid extraction in preconcentration of copper(II) in a ternary solvent system, *J. Hazard. Mater.* 161 (2009) 1535–1543.
- [13] J.P. Xiao, Q.X. Zhou, H.H. Bai, Preconcentration of copper with multi-walled carbon nanotubes pretreated by potassium permanganate cartridge for solid phase extraction prior to flame atomic absorption spectrometry, *Chin. Chem. Lett.* 18 (2007) 714–717.
- [14] A. Stafiej, K. Pyrzynska, Solid phase extraction of metal ions using carbon nanotubes, *Microchem. J.* 89 (2008) 29–33.
- [15] Ş. Tokalioğlu, S. Yildiz, A comparative study on the preconcentration of some metal ions in water samples with Cu(II) and Ni(II) salicylaldehyde coprecipitants, *Microchim Acta* 165 (2009) 129–133.
- [16] S.A.M. Fathi, M.R. Yaftian, Enrichment of trace amounts of copper(II) ions in water samples using octadecyl silica disks modified by a Schiff base ionophore prior to flame atomic absorption spectrometric determination, *J. Hazard. Mater.* 164 (2009) 133–137.
- [17] M. Ghaedi, F. Ahmadi, Z. Tavakoli, M. Montazerzohori, A. Khanmohammadi, M. Soylak, Three modified activated carbons by different ligands for the solid phase extraction of copper and lead, *J. Hazard. Mater.* 152 (2008) 1248–1255.
- [18] M.H. Mashhadizadeh, M. Pesteh, M. Talakesh, I. Sheikhshoae, M.M. Ardakani, M.A. Karimi, Solid phase extraction of copper (II) by sorption on octadecyl silica membrane disk modified with a new Schiff base and determination with atomic absorption spectrometry, *Spectrochim. Acta Part B* 63 (2008) 885–888.
- [19] A.P.S. Gonzáles, M.A. Firmino, C.S. Nomura, F.R.P. Rocha, P.V. Oliveira, I. Gaubeur, Peat as a natural solid-phase for copper preconcentration and determination in a multicommuted flow system coupled to flame atomic absorption spectrometry, *Anal. Chim. Acta* 636 (2009) 198–204.
- [20] Y.N. Lee, H.-S. Choi, Determination of copper(II) in various samples by flame atomic absorption spectrophotometry after column preconcentration onto pulverized Amberlite XAD-4 loaded with N-benzoylphenylhydroxylamine, *J. Anal. Chem.* 62 (2007) 845–851.
- [21] M. Soylak, M. Tuzen, A.S. Souza, G.A. Korn, S.L.C. Ferreira, Optimization of microwave assisted digestion procedure for the determination of zinc, copper and nickel in tea samples employing flame atomic absorption spectrometry, *J. Hazard. Mater.* 149 (2007) 264–268.
- [22] M. Ghaedi, K. Niknam, A. Shokrollahi, E. Niknam, H.R. Rajabi, M. Soylak, Flame atomic absorption spectrometric determination of trace amounts of heavy metal ions after solid phase extraction using modified sodium dodecyl sulfate coated on alumina, *J. Hazard. Mater.* 155 (2008) 121–127.
- [23] A. Mostafavi, D. Afzali, M.A. Taher, Atomic absorption spectrometric determination of trace amounts of copper and zinc after simultaneous solid-phase extraction and preconcentration onto modified natrolite zeolite, *Anal. Sci.* 22 (2006) 849–853.
- [24] A.M.H. Shabani, S. Dadfarnia, Z. Dehghani, On-line solid phase extraction system using 1,10-phenanthroline immobilized on surfactant coated alumina for the flame atomic absorption spectrometric determination of copper and cadmium, *Talanta* 79 (2009) 1066–1070.
- [25] B. Buke, U. Divrikli, M. Soylak, L. Elci, On-line preconcentration of copper as its pyrocatechol violet complex on Chromosorb 105 for flame atomic absorption spectrometric determinations, *J. Hazard. Mater.* 163 (2009) 1298–1302.
- [26] W. Ngeontae, W. Aeungmaitrepirom, T. Tuntulani, A. Imyim, Highly selective preconcentration of Cu(II) from seawater and water samples using amidoamidoxime silica, *Talanta* 78 (2009) 1004–1010.
- [27] M. Ghaedi, A. Shokrollahi, K. Niknam, M. Soylak, Cloud point extraction of copper, zinc, iron and nickel in biological and environmental samples by flame atomic absorption spectrometry, *Sep. Sci. Technol.* 44 (2009) 773–786.
- [28] A. Shokrollahi, M. Ghaedi, S. Gharaghani, M.R. Fathi, M. Soylak, Cloud point extraction for the determination of copper environmental samples by flame atomic absorption spectrometry, *Quim. Nova* 31 (2008) 70–74.
- [29] S. Tokalioğlu, V. Yilmaz, S. Kartal, Solid phase extraction of Cu(II), Ni(II), Pb(II), Cd(II) and Mn(II) ions with 1-(2-thiazolylazo)-2-naphthol loaded Amberlite XAD-1180, *Environ. Monit. Assess.* 152 (2009) 369–377.
- [30] D. Citak, M. Tuzen, M. Soylak, Simultaneous coprecipitation of lead, cobalt, copper, cadmium, iron and nickel in food samples with zirconium(IV) hydroxide prior to their flame atomic absorption spectrometric determination, *Food Chem. Toxicol.* 47 (2009) 2302–2307.
- [31] N. Burham, S.A. Azeem, M.F. El-Shahat, Solid phase selective separation and green preconcentration of Cu, Zn, Pb and Cd in drinking water by using novel functionalized resin, *Cent. Eur. J. Chem.* 7 (2009) 945–954.
- [32] B. Rezaei, E. Sadeghi, S. Meghdadi, Nano-level determination of copper with atomic absorption spectrometry after pre-concentration on N,N-(4-methyl-1,2-phenylene)diquinoline-2-carboxamide-naphthalene, *J. Hazard. Mater.* 168 (2009) 787–792.
- [33] X.W. Chen, L.L. Huang, R.H. He, Silk fibroin as a sorbent for on-line extraction and preconcentration of copper with detection by electrothermal atomic absorption spectrometry, *Talanta* 78 (2009) 71–75.
- [34] L.M. Coelho, M.A. Bezerra, M.A.Z. Arruda, R.E. Bruns, S.L.C. Ferreira, Determination of Cd, Cu, and Pb after cloud point extraction using multielemental sequential determination by thermospray flame furnace atomic absorption spectrometry (TS-FF-AAS), *Sep. Sci. Technol.* 43 (2008) 815–827.
- [35] Y.L. Yu, Z. Du, J.H. Wang, Determination of copper in seawater using a sequential injection system incorporating a sample pretreatment module coupled to electrothermal atomic absorption spectrometry, *Chin. J. Anal. Chem.* 35 (2007) 431–434.

- [36] P. Hashemi, S. Bagheri, M.R. Fathi, Factorial design for optimization of experimental variables in preconcentration of copper by a chromotropic acid loaded Q-Sephrose adsorbent, *Talanta* 68 (2005) 72–78.
- [37] S.L.C. Ferreira, W.N.L. Dos Santos, C.M. Quintella, B.B. Neto, J.M. Bosque-Sandra, Doehlert matrix: a chemometric tool for analytical chemistry-review, *Talanta* 63 (2004) 1061–1067.
- [38] C.R.T. Tarley, W.N.L.D. Santos, C.M.D. Santos, M.A. Zezzi Arruda, S.L.C. Ferreira, Factorial design and Doehlert matrix in optimization of flow system for preconcentration of copper on polyurethane foam loaded with 4-(2-pyridylazo)-resorcinol, *Anal. Lett.* 37 (2004) 1437–1455.
- [39] M. Tuzen, M. Soylak, D. Citak, H.S. Ferreira, M.G.A. Korn, M.A. Bezerra, A preconcentration system for determination of copper and nickel in water and food samples employing flame atomic absorption spectrometry, *J. Hazard. Mater.* 162 (2009) 1041–1045.
- [40] M.A. Farajzadeh, M. Bahram, B.G. Mehr, J.A. Johnson, Optimization of dispersive liquid–liquid microextraction of copper (II) by atomic absorption spectrometry as its oxinate chelate: application to determination of copper in different water samples, *Talanta* 75 (2008) 832–840.
- [41] M.T.P.O. Castro, N. Baccan, Application of factorial design in optimization of preconcentration procedure for copper determination in soft drink by flame atomic absorption spectrometry, *Talanta* 65 (2005) 1264–1269.
- [42] S.L.C. Ferreira, M.A. Bezerra, W.N.L.D. Santos, B.B. Neto, Application of Doehlert designs for optimisation of an on-line preconcentration system for copper determination by flame atomic absorption spectrometry, *Talanta* 61 (2003) 295–303.
- [43] R.A. Gil, N. Ferrúa, J.A. Salonia, R.A. Olsina, L.D. Martinez, On-line arsenic coprecipitation on ethyl vinyl acetate turning-packed mini-column followed by hydride generation-ICP OES determination, *J. Hazard. Mater.* 143 (2007) 431–436.
- [44] L. Escudero, R. Gil, J. Gasquez, R. Olsina, L.D. Martinez, Trace molybdenum determination in drinking waters by USN-ICP-OES after solid phase extraction on ethyl vinyl acetate turnings-packed minicolumn, *At. Spectrosc.* 29 (2008) 21–26.
- [45] R.A. Gil, M.M. Kaplan, J.A. Salonia, J.A. Gásquez, L.D. Martinez, Total inorganic Se and Te preconcentration and their determination by on-line coupling of a solid-phase extraction procedure with HG-AAS, *At. Spectrosc.* 28 (2007) 66–71.
- [46] MINITAB®, 1972–2003 Minitab Inc.