

Provided for non-commercial research and education use.
Not for reproduction, distribution or commercial use.



This article appeared in a journal published by Elsevier. The attached copy is furnished to the author for internal non-commercial research and education use, including for instruction at the authors institution and sharing with colleagues.

Other uses, including reproduction and distribution, or selling or licensing copies, or posting to personal, institutional or third party websites are prohibited.

In most cases authors are permitted to post their version of the article (e.g. in Word or Tex form) to their personal website or institutional repository. Authors requiring further information regarding Elsevier's archiving and manuscript policies are encouraged to visit:

<http://www.elsevier.com/copyright>



On-line ionic liquid-based preconcentration system coupled to flame atomic absorption spectrometry for trace cadmium determination in plastic food packaging materials

Estefanía M. Martinis^{a,b}, Roberto A. Olsina^{b,d}, Jorgelina C. Altamirano^{a,b,c}, Rodolfo G. Wuilloud^{a,b,c,*}

^a Laboratory of Environmental Research and Services of Mendoza (LISAMEN) (CCT – CONICET – Mendoza), Av. Ruiz Leal S/N Parque General San Martín, CC. 131, M 5502 IRA Mendoza, Argentina

^b Consejo Nacional de Investigaciones Científicas y Técnicas (CONICET), Argentina

^c Instituto de Ciencias Básicas, Universidad Nacional de Cuyo, Mendoza, Argentina

^d INQUISAL-CONICET, Departamento de Química Analítica, Facultad de Química, Bioquímica y Farmacia, Universidad Nacional de San Luis, Argentina

ARTICLE INFO

Article history:

Received 30 September 2008

Received in revised form 15 December 2008

Accepted 22 December 2008

Available online 15 January 2009

Keywords:

1-Butyl-3-methylimidazolium

hexafluorophosphate

Room temperature ionic liquid

Cadmium

On-line preconcentration

Plastic food packaging material

ABSTRACT

A novel on-line preconcentration method based on liquid–liquid (L–L) extraction with room temperature ionic liquids (RTILs) coupled to flame atomic absorption spectrometry (FAAS) was developed for cadmium determination in plastic food packaging materials. The methodology is based on the complexation of Cd with 2-(5-bromo-2-pyridylazo)-5-diethylaminophenol (5-Br-PADAP) reagent after sample digestion followed by extraction of the complex with the RTIL 1-butyl-3-methylimidazolium hexafluorophosphate ([C₄mim][PF₆]). The mixture was loaded into a flow injection analysis (FIA) manifold and the RTIL rich-phase was retained in a microcolumn filled with silica gel. The RTIL rich-phase was then eluted directly into FAAS. A enhancement factor of 35 was achieved with 20 mL of sample. The limit of detection (LOD), obtained as IUPAC recommendation, was 6 ng g⁻¹ and the relative standard deviation (R.S.D.) for 10 replicates at 10 µg L⁻¹ Cd concentration level was 3.9%, calculated at the peak heights. The calibration graph was linear and a correlation coefficient of 0.9998 was achieved. The accuracy of the method was evaluated by both a recovery study and comparison of results with direct determination by electrothermal atomic absorption spectrometry (ETAAS). The method was successfully applied for Cd determination in plastic food packaging materials and Cd concentrations found were in the range of 0.04–10.4 µg g⁻¹.

© 2009 Elsevier B.V. All rights reserved.

1. Introduction

Nowadays polymer packages are used preferentially in packaging foodstuffs. They are able to retard or even prevent detrimental changes in the food due to various external influences such as oxygen, light and microorganisms. They are also capable of reducing the loss in compounds such as water or flavour from the food [1]. Resulting from this protection, polymer packages enable consumers to store foodstuffs over an extended period of time. However, polymers contain additives such as plasticizers, lubricants, stabilizers and antioxidants [2], all chemicals which are necessary either for the processing or to maintain the stability of the final polymer package [3,4]. Recently, numerous studies showed that there is a

potential migration of additives from the packaging material into food [5–7]. Thus, packaging might pose a problem because of some of the additives used are extremely toxic. Cadmium is one of the toxic elements used extensively in the manufacturing of plastics [3]. Recently, the content of Cd in packaging materials undergoes European Community (EC) regulations. The EC Directive (94/62/EC) limits the concentration of Cd to 100 mg kg⁻¹ [8]. Due to its low excretion rate (biological half-life = 10–30 years) [9], Cd can be accumulated in the body and therefore, the presence of this metal is a problem even at low concentration levels [10]. Thus, sensitive, accurate, and fast analytical methods for trace metal determination in a variety of plastic materials are required.

Elemental analysis by spectrophotometric techniques involve the elution of target metal ions from polymer samples into the aqueous solution [11], before sensitive analytical techniques are needed for trace levels evaluation. Inductively coupled plasma-mass spectrometry (ICP-MS) has been used for the determination of Cd in plastics [12]; however, the cost of such instrumentation may still be prohibitive to many laboratories. Although flame atomic absorption spectrometry (FAAS) or electrothermal atomic absorption spectrometry (ETAAS) are the most commonly used techniques

* Corresponding author at: Laboratory of Environmental Research and Services of Mendoza (LISAMEN) (CCT – CONICET – Mendoza), Av. Ruiz Leal S/N Parque General San Martín, CC. 131, M 5502 IRA Mendoza, Argentina. Tel.: +54 261 5244064; fax: +54 261 5244001.

E-mail address: rwuilloud@mendoza-conicet.gov.ar (R.G. Wuilloud).

URL: <http://www.cricyt.edu.ar/lisamen/> (R.G. Wuilloud).

to determine Cd, FAAS is widely applied in routine laboratories due to its low cost and greater simplicity as compared to ETAAS. However, conventional FAAS has a detection limit, which is not low enough to determine Cd at trace levels in plastics. In order to achieve accurate, sensitive and reliable results at trace levels; preconcentration and separation steps are needed prior to analyte determination by FAAS.

The use of room temperature ionic liquids (RTILs) as an alternative to other techniques for separation and preconcentration has attracted considerable attention in recent years [13,14]. RTIL are salts resulting from combinations of organic cations and various anions [15]. The unique physicochemical properties of RTILs, including air and moisture stability, non-volatility, good thermal stability, tunable viscosity and miscibility with water and organic solvents, the fact that they remain liquid at room temperature, make their use particularly attractive in separation processes [16]. Recently, numerous studies have shown their good extractability for various organic compounds and metal ions [17]. However, up to date all the extraction/preconcentration methodologies based on RTIL involve batch procedures [14,18] and no on-line system has been developed so far for RTIL phase separation. It is well known that when preconcentration methods are applied in a batch mode, the risk of contamination is very high and the operation is usually too time-consuming. On the other hand, 2-(5-bromo-2-pyridylazo)-5-diethylaminophenol (5-Br-PADAP) forms stable complexes with numerous metal ions [19–22], and is therefore a suitable reagent for Cd extraction/preconcentration with a RTIL [23].

In this work, a novel on-line RTIL-based preconcentration system for Cd determination at trace levels in plastic food packaging materials is presented. The on-line coupling of a FI preconcentration and separation system to FAAS represents an efficient and simple methodology for routine analysis. Cadmium preconcentration was mediated by chelation with the 5-Br-PADAP reagent, followed by extraction with the RTIL 1-butyl-3-methylimidazolium hexafluorophosphate ($[C_4mim][PF_6]$) [24]. On-line retention and separation of the RTIL phase was achieved with a microcolumn filled with silica gel. The method was successfully applied to Cd determination in plastic materials, demonstrating the possibility of using RTILs for metal extraction from complex matrices.

2. Experimental

2.1. Apparatus

The experiments were performed using a PerkinElmer 5100PC atomic absorption spectrometer (PerkinElmer, Norwalk, CT, USA), equipped with a FIAS 200 flow injection analysis system (PerkinElmer). A Cd electrodeless discharge lamp (PerkinElmer) operated at a current of 240 mA and a wavelength of 228.8 nm with a spectral band width of 0.7 nm was used. A deuterium background corrector was used. All instrumental parameters are listed in Table 1.

The flow injection system is shown in Fig. 1. Tygon-type pump tubes (Gilson) were employed to propel the sample and reagent. On the other hand, solvent-resistant pump tubes (PerkinElmer) were employed for the organic eluent. A microbore glass column (40 mm length; 2 mm internal diameter) filled with the retention material and fitted with porous 25 μm glass frits, was used for on-line retention of the RTIL phase.

2.2. Reagents

All the reagents were of analytical grade and the presence of Cd was not detected within the working range. A 10^{-2} mol L $^{-1}$ 5-Br-PADAP (Aldrich, Milwaukee, WI, USA) solution was prepared in

Table 1

Instrumental and experimental conditions for Cd determination.

Instrumental conditions	
Wavelength (nm)	228.8
Spectral band width (nm)	0.7
Lamp current (mA)	240
Type of flame	Air/C ₂ H ₂
Fuel flow (L min $^{-1}$)	2
Oxidant flow (L min $^{-1}$)	10
Extraction conditions	
Working pH	9
Sample volume (mL)	20
Cd ²⁺ concentration ($\mu\text{g L}^{-1}$)	10
5-Br-PADAP concentration ($\times 10^{-6}$ mol L $^{-1}$)	7.5
Buffer concentration ($\times 10^{-6}$ mol L $^{-1}$)	4
Surfactant concentration (w/v)	0.1%
Amount of RTIL (g)	0.7
Eluent	Acidified EtOH
Loading flow rate (mL min $^{-1}$)	4
Elution flow rate (mL min $^{-1}$)	6

ethanol (Merck, Darmstadt, Germany). Lower concentrations were prepared by serial dilution with ethanol. A 1000 mg L $^{-1}$ Cd²⁺ stock solution was prepared from Cd(II) nitrate (Merck) in 0.1 mol L $^{-1}$ nitric acid (Merck). Lower concentrations were prepared by diluting the stock solution with 0.1 mol L $^{-1}$ nitric acid. The buffer solution was 2.0 mol L $^{-1}$ ammonium hydroxide (Merck) adjusted to pH 9.0 with hydrochloric acid (Merck). A surfactant solution containing 5% (w/v) Triton X-100 (Merck) was employed to avoid RTIL phase sticking onto the Tygon tube walls. Silica gel (100 Å pore size, 70–230 mesh particle size, Aldrich) was used to fill in the microcolumn. The RTIL $[C_4mim][PF_6]$ was purchased from Solvent Innovation GmbH (Köln, Germany) and it was stored in contact with ultrapure water to equilibrate the water content in the RTIL phase. Ultrapure water (18 M Ω cm) was obtained from a Millipore Continental Water System.

2.3. Sample conditioning

A range of materials commonly used in the food industry were studied, including polyethylene terephthalate (PET), high density polyethylene (HDPE), polyvinyl chloride (PVC), low density polyethylene (LDPE) polypropylene (PP) and polystyrene (PS). Packages representative of different applications were selected: bottles, cups and plastic bags. The samples were cut into small pieces. A wet

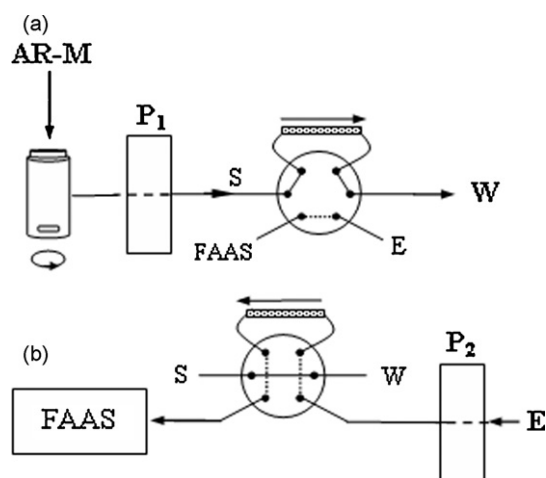

Fig. 1. Schematic diagram of the instrumental setup. AR-M: reagents adding and mixing; S: sample and reagents; E: eluent; W: waste; P: peristaltic pump; M: microcolumn; V: load-injection valve. (a) Preconcentration step (load position) and (b) elution step (injection position).

Table 2
Operation sequence for FI on-line preconcentration and separation system.

Step	Time (s)	Valve position	Pump active	Medium pumped	Flow rate (mL min ⁻¹)	Function
1	10	Fill	P ₁	Buffer-diluted solution	4	pH conditioned
2 (Fig. 1(a))	300	Fill	P ₁	Sample reagent RTIL	4	Load sample
3	10	Fill	P ₁	Buffer-diluted solution	4	Remove sample present in the line, vial and column
4 (Fig. 2)	6	Inject	P ₂	Acidified EtOH	6	Elute analyte into the flame
5	5	Inject	P ₂	Acidified EtOH	6	Remove residual solutions

digestion procedure was followed for all packaging material, 0.5 g of sample was weighted and 5 mL sulfuric acid, 5 mL nitric acid and 5 mL perchloric acid were added in a glass beaker. The mixture was kept boiling on a heating plate for 1 h. The mixture was partially covered with a watch glass to avoid total evaporation. After cooling, the solution was transferred to a 100 mL volumetric flask and diluted to the mark with water. An aliquot of 20 mL of the resulting solution was used for the determination.

2.4. On-line separation and preconcentration procedure

A schematic diagram of the preconcentration and determination system is shown in Fig. 1. The operation sequence for FI on-line preconcentration and separation system is listed in Table 2. In the preconcentration stage (Fig. 1(a)), 20 mL of sample solution, 0.15 mL of 10⁻³ mol L⁻¹ 5-Br-PADAP solution, 0.4 mL of 5% (w/v) Triton X-100, 0.4 mL of 2 mol L⁻¹ (pH 9.0) buffer solution and 0.7 g of [C₄mim][PF₆] were placed in a vial. The resultant system was shaken for about 5 s with a stirring bar before and during the loading of the mixture into the column at a flow rate of 4 mL min⁻¹. The RTIL phase containing the Cd–5-Br-PADAP complex was thus retained by the filling material of the column. It has to be pointed out that, before loading, the column was conditioned for preconcentration at the correct pH with a buffer-diluted solution. After loading, further washing with buffer-diluted solution served to remove any sample still present in the lines and in the column. In the elution step (Fig. 1(b)), the injection valve was switched on and the retained RTIL rich-phase was eluted with ethanol acidified with 0.5 mol L⁻¹ nitric acid at a flow rate of 6 mL min⁻¹ directly into the nebulizer of FAAS instrument and Cd was determined under the conditions shown in Table 1.

Calibration was performed against aqueous standards submitted to the same preconcentration procedure. Likewise, blank solutions were analyzed in the same manner as standard and sample solutions. For optimizing the preconcentration and determination system, 20 mL of 1 µg L⁻¹ Cd²⁺ standard solution was used instead of the samples.

3. Results and discussion

3.1. Column manufacturing and on-line RTIL phase collection

It was supposed that, the high viscosity of the RTIL [C₄mim][PF₆] (352.2 mPa s) in combination with a controlled loading flow rate of the RTIL-aqueous mixture through the column, would lead to RTIL phase retention. Therefore, home-made columns packed with a potentially suitable filtering material such as, cotton, polyurethane foam or silica gel [25], were tested to pursue on-line collection and separation of the RTIL phase. For soft filling materials, such as cotton and polyurethane foam, the RTIL phase was not completely retained in the column. In fact, the RTIL phase passed through the cotton fibers or holes in the foam, making difficult its retention. On the other hand, silica gel proved to be highly effective for retention whereas keeping the RTIL phase in a more localized region inside the column. This yielded sharper and well-defined peaks as compared to the other filling materials.

Column design is a critical parameter for defining peak form of transient signals originated in a FI on-line preconcentration system. The sharper the peaks, the higher will be the sensitivity when analyte quantification is performed based on peak height. Therefore, inner diameter and length of the column were important variables to be considered in this work. It was observed that a minimal length of 40 mm was necessary for total RTIL phase retention. Shorter columns did not show good retention as the RTIL phase was not completely entrapped by the filling material. On the other hand, longer columns did not bring further enhancement of the analytical signal and a higher back pressure was generated within the FI system. Another variable considered in the column design was the inner diameter. Thus, a reduced inner diameter was preferred in order to achieve low dispersion of the peak signal. A 2-mm inner diameter was found to be effective for RTIL phase retention.

3.2. Optimization of the loading variables

Several variables were studied in order to optimize Cd–5-Br-PADAP complex formation and extraction, as well as retention of the RTIL phase into the column. Among them, pH, surfactant and chelating agent concentration, RTIL amount and loading flow rate were studied. Additionally, the conditions for suitable elution of the analyte from the column were studied.

The optimal pH values were in the range of 7.8–10.2. This phenomenon is understandable, since the best complexation of Cd with the 5-Br-PADAP reagent occurs within this range [20,23]. According to these results, the selected pH was 9.0. The minimum reagent to metal ion molar ratio necessary to reach the optimum response was 100. Above this ratio, no variation in the analytical response was observed. Therefore, a 150 5-Br-PADAP to metal ion molar ratio was selected for further work. It corresponds to 7.5 × 10⁻⁶ mol L⁻¹ 5-Br-PADAP concentration.

In order to avoid the precipitation of the complexing agent and Cd–5-Br-PADAP complex in aqueous medium prior to the extraction, Triton X-100 was added to the sample solution. Moreover, the surfactant also reduced the adherence of the RTIL on the inner walls of the tubes, thus improving the flowing ability of the RTIL throughout the FI system and forcing the sole retention into the column. In the presence of a non-ionic surfactant such as Triton X-100, the fine droplets of RTIL are surrounded by their molecules. Hence, RTIL interactions with the inner walls of the lines decrease and consequently, RTIL phase do not stick on it [26]. Although the presence of a surfactant facilitates the flowing of the RTIL phase, it can negatively affect the retention of the RTIL phase by the filling material of the column. Therefore, the effect of Triton X-100 on Cd–5-Br-PADAP extraction and later RTIL phase retention into the column was studied within a surfactant concentration range of 0.01–2.0% (w/v). This study showed that both the complexing agent and the metallic complex remained in solution within range studied. A 0.1% (w/v) surfactant concentration was chosen for further work as yielded high extraction efficiency while keeping the complex in solution (Fig. 2). Higher surfactant concentrations led to inefficient retention into the column, and hence non-reproducible results. Moreover, the greatest analyte enhancement factor was reached at 0.1% (w/v) surfactant concentration.

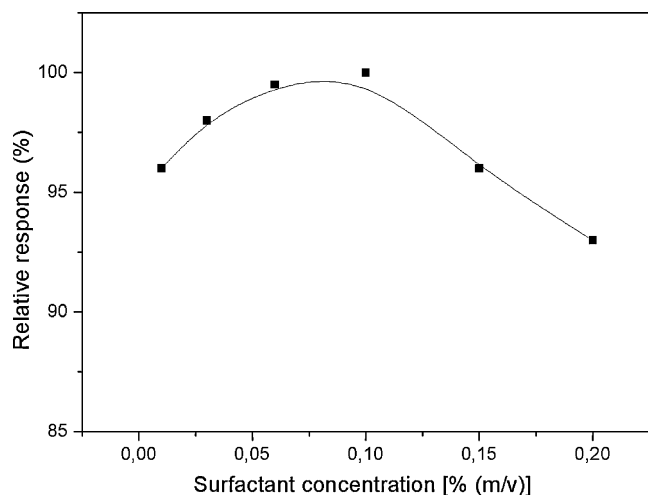

Fig. 2. Effect of Triton X-100 concentration on the efficiency of the preconcentration system. Experimental conditions are listed in Table 1.

Optimization of the minimal sample volume required to be injected into FI-FAAS is crucial in order to reach a suitable response. Therefore, it is highly important to establish the minimal volume of RTIL that leads to total complex extraction while achieving the highest signal. The variation of the analyte signal upon the RTIL amount was examined within the range: 0.4–1.2 g. It was observed that the extraction efficiency of the system and the signal were remarkably affected by the RTIL amount. Quantitative extraction and higher signal was observed for a minimal RTIL amount of 0.6 g. No significant changes were observed on the extraction efficiency by adding higher RTIL amounts. On the other hand, it was considered the effect of RTIL amount on the retention capacity of the column. Experiments performed with different RTIL amounts showed that effective retention of the phase was achieved up to 0.7 g RTIL. A significant reduction in the RTIL retention was observed for higher RTIL amounts. Thus, in order to achieve the best enhancement factor, 0.7 g RTIL amount was chosen as optimal. Under these conditions, a final RTIL volume of 500 μL was obtained.

The sample flow rate through the column is an important parameter, since this is one of the steps that controls the time of analysis. Moreover, the effect of sample flow rate through the column was a critical variable to achieve high retention of the RTIL phase. The influence of the sample loading flow rate on the analytical response was not critical between 1 and 5 mL min^{-1} . The response decreased at flow rate values higher than 5 mL min^{-1} , and even none retention of the RTIL phase was observed when the flow rate was as high as 20 mL min^{-1} . This phenomenon allows us to state that retention of the RTIL phase into the column is mainly produced due to a filtering-like process, rather than a chemical one. In fact, the high viscosity of the RTIL $[\text{C}_4\text{mim}][\text{PF}_6]$ could be the main reason for allowing the sample to pass through the ionic liquid plug and the column [27]. The capacity of retention of the column was 90%. The dependence of the percent of recovery of Cd on sample loading flow rate is shown in Fig. 3. A flow rate of 4 mL min^{-1} was chosen for further work.

3.3. Elution of the RTIL phase from the column

To elute the RTIL phase retained within the column, a group of solvents miscible with $[\text{C}_4\text{mim}][\text{PF}_6]$ were studied. Therefore, common organic solvents such as ethanol, methanol, and acetone were chosen. The selection of these solvents was made based on the high solubility that $[\text{C}_4\text{mim}][\text{PF}_6]$ shows in these media [28–30]. Both acetone and ethanol resulted to be the most effective for RTIL phase and Cd–5-Br-PADAP complex removal from the column. However,

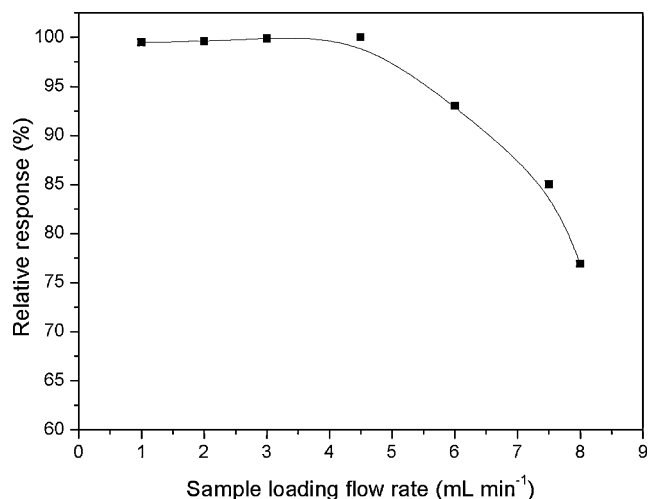

Fig. 3. Dependence of recovery of Cd on loading sample flow rate. Experimental conditions are listed in Table 1.

it was preferred ethanol to acetone due to major compatibility of the alcohol with tubes and valve materials used in the FI system. Likewise, sharper peaks were observed with ethanol. Finally, the eluent was acidified with nitric acid in order to induce dissociation of Cd–Br-PADAP complex and further releasing of Cd into solution. A nitric acid concentration of 0.5 mol L^{-1} was chosen.

The effect of flow rate of eluent on analyte signal is shown in Fig. 4. As can be seen, the optimum flow rate of eluent was 6 mL min^{-1} . Therefore, the elution flow rate was compatible with the aspiration flow of the FAAS instrument [31]. Additionally, elution of the analyte through the column was developed in counter-current, which was especially favorable to obtain sharp and well-defined peaks.

The combination of $[\text{C}_4\text{mim}][\text{PF}_6]$ with other “green” solvent such as ethanol, avoided the use of hazardous toxic and flammable solvents, while increasing FAAS sensitivity with respect to an aqueous solvent. The analyte was completely eluted from the column in 6 s.

3.4. Extraction and analytical performance

An extraction percentage higher than 99.9% was achieved when the procedure was carried out under the optimal experimental con-

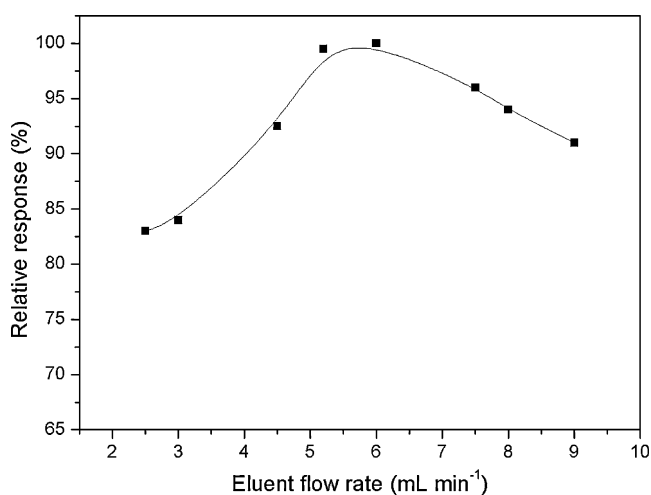

Fig. 4. Dependence of recovery of Cd on elution flow rate. Experimental conditions are listed in Table 1.

Table 3
Accuracy of the proposed method (95% confidence interval; $n=6$).

Sample	Base value ($\mu\text{g L}^{-1}$)	Quantity of Cd^{2+} added ($\mu\text{g L}^{-1}$)	Quantity of Cd^{2+} found ($\mu\text{g L}^{-1}$)	Recovery (%) ^a
PET	1.0	–	1.0 ± 0.08	–
	1.0	5	6.1 ± 0.29	102
	1.0	10	11.1 ± 0.47	101
HDPE	0.61	–	0.61 ± 0.06	–
	0.61	5	5.7 ± 0.32	102
	0.61	10	10.5 ± 0.45	99
PVC	25.0	–	25.0 ± 0.98	–
	25.0	5	30.0 ± 1.29	100
	25.0	10	35.1 ± 1.45	101
LDPE	0.55	–	0.55 ± 0.06	–
	0.55	5	5.45 ± 0.37	98
	0.55	10	10.5 ± 0.49	100
PP	0.70	–	0.68 ± 0.07	–
	0.70	5	5.6 ± 0.28	98
	0.70	10	10.6 ± 0.44	99
PS	1.1	–	1.1 ± 0.10	–
	1.1	5	6.1 ± 0.31	100
	1.1	10	11.3 ± 0.49	102

^a $100 \times [(\text{Found} - \text{base})/\text{added}]$.

ditions (Table 1). The obtained enhancement factor for a sample volume of 20 mL was 35. The enhancement factor was obtained as the ratio of the slopes of the calibration curves for Cd with and without the preconcentration step.

The relative standard deviation (R.S.D.) resulting from the analysis of 10 replicates of 20 mL solution containing $10 \mu\text{g L}^{-1}$ Cd^{2+} was 3.9%. The calibration graph was linear with a correlation coefficient of 0.9998 at levels near the detection limits and up to at least $50 \mu\text{g L}^{-1}$. The regression equation was $A = 0.0219C + 0.007$, where A is the absorbance and C is the concentration of Cd in $\mu\text{g L}^{-1}$. The limit of detection (LOD), calculated based on three times the standard deviation of the background signal (3σ), was 6 ng g^{-1} . The frequency of analysis was nine samples per hour.

3.5. Accuracy of the method and cadmium determination in real samples

To demonstrate the accuracy of the proposed method, a recovery study was performed evaluating any matrix interferences and/or possible analyte losses during the sample pre-treatment of different food packaging materials: PET, HDPE, PVC, LDPE, PP and PS. Thus, the method was applied to six portions of 0.5 g for each plastic material. All the samples were digested and analyzed following the procedure described before. The average concentration of Cd found was taken as a base value. Then, increasing quantities of Cd were added to the other aliquots of sample and the analyte was determined by the same method. As shown in Table 3, analyte recoveries were all around 100%.

The method was applied for Cd determination in different food packaging plastic materials collected from the local market. Cadmium concentrations were in the range of n.d.– 0.20 mg kg^{-1} for PET; n.d.– 0.12 mg kg^{-1} for HDPE; 5.1 – 10.4 mg kg^{-1} for PVC; n.d.– 0.11 mg kg^{-1} for LDPE; n.d.– 0.14 mg kg^{-1} for PP and n.d.– 0.22 mg kg^{-1} for PS, at 95% confidence interval ($n=6$). The proposed method was also validated by comparison of the results obtained by a different technique (Table 4). Determinations by ETAAS were performed by measuring direct aliquots of the digested samples. This was possible due to the low LOD that are possible to reach for Cd with ETAAS. The results were compared by applying the F -test and no significant differences at the 95% confidence level were observed.

Table 4
Concentration of Cd in food packaging materials (95% confidence interval; $n=6$).

Sample	Proposed method (mg kg^{-1})	ETAAS (mg kg^{-1})
PET	0.05 ± 0.01	0.07 ± 0.01
	0.20 ± 0.02	0.19 ± 0.02
	n.d. ^a	n.d. ^a
HDPE	0.12 ± 0.01	0.12 ± 0.01
	n.d. ^a	n.d. ^a
	n.d. ^a	n.d. ^a
PVC	5.1 ± 0.22	5.1 ± 0.32
	10.4 ± 0.42	10.5 ± 0.51
	8.4 ± 0.40	8.4 ± 0.49
LDPE	0.05 ± 0.01	0.07 ± 0.01
	0.11 ± 0.02	0.14 ± 0.02
	n.d. ^a	n.d. ^a
PP	n.d. ^a	n.d. ^a
	0.09 ± 0.01	0.10 ± 0.01
	0.14 ± 0.02	0.12 ± 0.01
PS	0.22 ± 0.03	0.21 ± 0.03
	0.04 ± 0.01	0.05 ± 0.01
	n.d. ^a	n.d. ^a

^a Non-detectable.

4. Conclusion

In this work, an original FI system with on-line RTIL phase separation coupled to FAAS detection for Cd determination in plastic materials is proposed. Thus, the excellent extraction efficiency associated with RTILs in combination with the possibility of performing an on-line procedure opens up an attractive alternative in the area of automated separation and preconcentration methodologies. The on-line retention of the RTIL phase by using a silica gel-packed column simplifies the preconcentration methodology while reducing manual operation and risk of contamination. Furthermore, the effect of several variables, including physical, chemical and hydrodynamic characteristics, on the on-line retention of the RTIL phase has been studied. A sensitivity enhancement factor of 35 was achieved. The use of the 5-Br-PADAP–[C₄mim][PF₆] extraction system allowed the reliable and accurate determination of Cd in food packaging material.

Acknowledgements

This work was supported by Consejo Nacional de Investigaciones Científicas y Técnicas (CONICET) and Agencia Nacional de Promoción Científica y Tecnológica (FONCYT) (PICT-BID) (FONTAR – NO PMT II – CAI/073) (Argentina).

References

- [1] K. Marsh, B. Bugusu, *J. Food Sci.* 72 (2007) R39.
- [2] A.W. Birley, *Food Chem.* 8 (1982) 81.
- [3] D.O. Hummel, *Atlas of Plastics Additives—Analysis by Spectrometric Methods*, Springer, Germany, 2002.
- [4] I.D. Rosca, J.M. Vergnaud, *Polym. Test* 25 (2006) 532.
- [5] D. Thompson, S.J. Parry, R. Benzing, *J. Radioanal. Nucl. Chem.* 213 (1996) 349.
- [6] M.W. Kadi, *Asian J. Chem.* 17 (2005) 40.
- [7] W. Shotyky, M. Krachler, *Environ. Sci. Technol.* 41 (2007) 1560.
- [8] A. Ritter, E. Michel, M. Schmid, *S. Affolter, Polym. Test* 23 (2004) 467.
- [9] R.B. Hayes, *Cancer Causes Contr.* 8 (1997) 371.
- [10] T. Nawrot, M. Plusquin, J. Hogervorst, H.A. Roels, H. Celis, L. Thijs, J. Vangronsveld, E. Van Hecke, J.A. Staessen, *Lancet Oncol.* 7 (2006) 119.
- [11] H. Sakurai, J. Noro, A. Kawase, M. Fujinami, K. Oguma, *Anal. Sci.* 22 (2006) 225.
- [12] E. Skrzydlewska, M. Balcerzak, *Chem. Anal. Wars.* 48 (2003) 909.
- [13] F. Kubota, M. Goto, *Solvent Extr. Res. Dev.* 13 (2006) 23.
- [14] Z. Li, J. Chang, H. Shan, J. Pan, *Rev. Anal. Chem.* 26 (2007) 109.
- [15] G. Singh, A. Kumar, *Indian J. Chem. A* 47 (2008) 495.
- [16] H. Zhao, S. Xia, P. Ma, *J. Chem. Technol. Biotechnol.* 80 (2005) 1089.
- [17] J.F. Liu, G.B. Jiang, J.A. Jönsson, *TrAC, Trends Anal. Chem.* 24 (2005) 20.

- [18] S. Pandey, *Anal. Chim. Acta* 556 (2006) 38.
- [19] M.A. Taher, A. Mostafavi, S.Z.M. Mobarake, D. Afzali, *Bull. Chem. Soc. Ethiopia* 20 (2006) 1.
- [20] R.F. Lara, R.G. Wuilloud, J.A. Salonia, R.A. Olsina, L.D. Martinez, *Anal. Bioanal. Chem.* 371 (2001) 989.
- [21] P.R. Aranda, R.A. Gil, S. Moyano, I.E. De Vito, L.D. Martinez, *Talanta* 75 (2008) 307.
- [22] J.C.A. De Wuilloud, R.G. Wuilloud, M.F. Silva, R.A. Olsina, L.D. Martinez, *Spectrochim. Acta, Part B* 57 (2002) 365.
- [23] E.M. Martinis, R.A. Olsina, J.C. Altamirano, R.G. Wuilloud, *Anal. Chim. Acta* 628 (2008) 41.
- [24] S. Carda-Broch, A. Berthod, D.W. Armstrong, *Anal. Bioanal. Chem.* 375 (2003) 191.
- [25] J. Nan, Y. Jiang, X.P. Yan, *J. Anal. At. Spectrom* 18 (2003) 946.
- [26] M. Baghdadi, F. Shemirani, *Anal. Chim. Acta* 613 (2008) 56.
- [27] M. Cruz-Vera, R. Lucena, S. Cárdenas, M. Valcárcel, *J. Chromatogr. A* 1202 (2008) 1.
- [28] K.A. Fletcher, S. Pandey, *J. Phys. Chem. US* 107 (2003) 13532.
- [29] J. Zhang, W. Wu, T. Jiang, H. Gao, Z. Liu, J. He, B. Han, *J. Chem. Eng. Data* 48 (2003) 1315.
- [30] M.T. Zafarani-Moattar, R. Majdan-Cegincara, *J. Chem. Eng. Data* 52 (2007) 2359.
- [31] H. Chen, J. Liu, X. Mao, *Anal. Chim. Acta* 370 (1998) 151.