



## RESEARCH ARTICLE

# Historical biogeographic analysis of the family Fanniidae (Diptera: Calyptratae), with special reference to the austral species of the genus *Fannia* (Diptera: Fanniidae) using dispersal-vicariance analysis

Análisis biogeográfico histórico de la familia Fanniidae (Diptera: Calyptratae), con referencia especial a las especies australes del género *Fannia* (Diptera: Fanniidae) usando análisis de dispersión-vicarianza

M. CECILIA DOMÍNGUEZ\* & SERGIO A. ROIG-JUÑENT

Laboratorio de Entomología, Instituto Argentino de Investigaciones de Zonas Áridas (IADIZA), Centro Científico Tecnológico (CCT-CONICET, Mendoza), Av. Adrián Ruiz Leal s/n, Parque Gral. San Martín, Mendoza, Argentina, CC: 507, CP: 5500

\*Corresponding author: mcdomin@mendoza-conicet.gov.ar

## ABSTRACT

The purpose of this study was to achieve a hypothesis explaining the biogeographical history of the family Fanniidae, especially that of the species from Patagonia, the Neotropics, Australia, and New Zealand. We used “dispersal-vicariance analysis” (DIVA), an event-based parsimony method, to analyze the most parsimonious phylogenetic hypothesis for the family, obtained by Domínguez & Roig-Juñent (2008). The analysis resulted in 32800 alternative equally optimal reconstructions that indicate that the ancestor of the Fanniidae was widely distributed across different regions of the world, which along with the subsequent separation of two clades that correspond to the Laurasian and Gondwanan Landmasses allow the proposal of an older age than in previous hypothesis (Late Jurassic or early Cretaceous times instead of upper Cretaceous) and a Pangeic origin for the Fanniidae. The northern hemisphere species of Fanniidae included in this study highlight the difficulty that arises when analysing with DIVA a tree with a large amount of paralogy or redundant distributions, as illustrated here with several examples. The southern hemisphere species of Fanniidae indicate a clear pattern of vicariance and dispersal consistent with the rapture of Gondwana.

**Key words:** age of Fanniidae, dispersal, DIVA, Gondwana, vicariance.

## RESUMEN

El propósito de este estudio fue el de obtener una hipótesis que explique la historia biogeográfica de la familia Fanniidae, especialmente la de las especies de las regiones Patagónica, Neotropical, Australiana y Neozelandesa. Se utilizó el método de “dispersión y vicarianza” (DIVA), el cual es un método de parsimonia basado en eventos para analizar el árbol filogenético más parsimonioso obtenido por Domínguez & Roig-Juñent (2008). El análisis resultó en 32800 reconstrucciones alternativas igualmente óptimas que indican que el ancestro de Fanniidae estaba ampliamente distribuido en distintas regiones del mundo, lo cual junto con la subsiguiente separación de dos clados que corresponderían a los territorios de Laurasia y Gondwana permiten proponer una edad más temprana que la de hipótesis previas (Jurásico tardío o Cretácico temprano en lugar de Cretácico tardío) y un origen pangeico para la familia Fanniidae. Las especies septentrionales de Fanniidae incluidas en este análisis destacan las dificultades que surgen cuando un cladograma con gran cantidad de paralogía o distribuciones redundantes se analiza con DIVA. Las especies australes de Fanniidae muestran un patrón de vicarianza y dispersión que es congruente con la ruptura de Gondwana.

**Palabras clave:** dispersión, DIVA, edad de Fanniidae, Gondwana, vicarianza.

## INTRODUCTION

The Fanniidae is a small family of the Calyptratae series of Diptera, that is distributed worldwide, but the highest species diversity is found in temperate areas of both hemispheres and contains some 300 described

species. The family has been found to be inhabitant of forests, and considered rare in open landscapes and wetlands (Rozkošný et al. 1997). The species of *Fannia* belonging to the *Fannia anthracina* Stein species-group show distributions related to the *Notophagous* forests endemic to the Chilean and Argentinean

Patagonia, however *Fannia fusconotata* (Rondani) (endemic to the province of Mendoza, Argentina) and *Fannia heydenii* (Wiedemann) have been found in open arid shrub lands and open woodlands of *Prosopis* (Domínguez 2007).

Males of almost all species form swarms under tree branches, above forest paths, or in the case of synantropic species in shaded indoors. Members of these swarms hover in the air like hover flies (Syrphidae) (Rozkošný et al. 1997). Among the southern South American species, the males of *F. fusconotata* were found swarming very low near water streams and near vegetation and *Fannia hermani* Domínguez was found swarming directly above a water stream (Domínguez 2007).

The wide distribution of this family may be due to the feeding habits of its larvae, which are mostly saprophagous and feed among decaying organic material which also accounts for its association with man (Rozkošný et al. 1997). The medical and hygienic importance of the wide-spread species of *Fannia* such as *F. canicularis* (Linnaeus), *F. femoralis* (Stein), *F. incisurata* (Zetterstedt), *F. pusio* (Wiedemann), *F. scalaris* (Fabricius) are well known. *F. canicularis* and *F. scalaris* have been reared from various decaying materials in gardens. Moreover, the larvae of *F. scalaris* are frequent in cesspools, latrines and dunghills, having also been reared, accompanied by *F. canicularis* from human faeces. Some of the most abundant species occur regularly in agricultural pens used for breeding pigs, cattle, horses or fowls, and in fur farms. The larvae apparently develop in animal droppings and dung (Rozkošný 1997). Some species such as *F. fusconotata*, and *F. canicularis* and *F. scalaris* are believed to cause different types of myiasis in man and in cattle (Mazza & Oribe 1939, Oliva 1997). Furthermore, many species of Fanniidae are considered important in forensic investigations (Smith 1986, Oliva 1997), in recent studies in Argentina they have been found in decaying pig carcasses (Domínguez & Aballay 2009, Quiroga & Domínguez 2010).

Females are usually attracted to decaying material and excrement, but a few so-called secretophagous species attack cattle in pastures as well as perspiring people in

summer, mainly *F. fusconotata* and *F. coxata* Shannon & Del Ponte (Domínguez 2007).

Although many species of Fanniidae are widely distributed, such as *Fannia canicularis* (the lesser house fly), *F. scalaris* (the latrine fly), *F. pusio* and *Euryomma peregrinum* Meigen, most species are restricted to large biogeographic regions, such as the Holarctic, Australia, New Zealand, Africa and South America.

Chillcott (1961a) and Hennig (1965), proposed the Holarctic Region, where the largest number of species of Fanniidae occur, as the centre of origin of the family. Their hypothesis agrees with the "holarticist theory" which was accepted as a paradigm during the resurgence of Darwinism. Darlington (1965) defended this theory to explain the origin of the austral faunas, proposing that the centre of origin of many austral taxa had been in the large Holarctic landmasses. He postulated that, through dispersal, the most evolved Holarctic groups could have independently invaded the Austral regions.

The biogeographic proposals for the family Fanniidae by Chillcott (1961a) and Hennig (1965) were mostly based on dispersal, with an emphasis on the biogeographical history of the Holarctic species and Chillcott's classification of the family. A recent phylogenetic hypothesis for the family Fanniidae (Domínguez & Roig-Juñent 2008) incorporates newly described or poorly known species of the family from Africa, the Neotropics, Patagonia, Australia and New Zealand, showing that, as Hennig (1965) suggested, the Neotropical species of Fanniidae do not form a monophyletic unit. But contrary to Hennig's (1965) hypothesis, they are more closely related to species of other austral regions of the world than to the Holarctic species of the family. This could indicate a more complex biogeographic history than the one interpreted by Chillcott (1961a) and Hennig (1965), and where vicariance should be taken into consideration.

Disjunct or allopatric distributions have been explained by two historical processes: dispersal and vicariance. Vicariance is usually assumed to be the primary explanation; and since almost any distribution pattern can be explained by dispersal, dispersal hypotheses are presumably resilient to falsification (Morrone & Crisci 1995, Sanmartín 2007).

Congruence between the phylogenetic and distribution patterns of different organisms is thought to provide evidence for vicariance hypotheses, on the other hand, dispersal is considered uncommon and not a general explanation for congruence among patterns (Croizat et al. 1974, Craw 1982, Heads 1999, Humphries 2001). Nevertheless, recent studies have shown that, in some cases, concerted dispersal occurs (when dispersion takes place repeatedly in the same direction between the same areas), producing congruent distribution patterns (Winkworth et al. 2002, Sanmartín & Ronquist 2004, Sanmartín 2007).

The purpose of this study was to obtain a hypothesis explaining the biogeographical history of the family Fanniidae. We were especially interested in clarifying the biogeographical history of the "Southern" species of Fanniidae, including the Patagonian species, as well as those recently described from Australia and New Zealand, with the aim of testing Chillcott's (1961a) and Hennig's (1965) hypotheses about the biogeographic history of the South American species of the family Fanniidae.

## METHODS

In this study, we used "dispersal-vicariance analysis" (DIVA) (Ronquist 1996, 1997), an event-based parsimony method, to reconstruct the biogeographical history of the family Fanniidae (Diptera: Calyptratae). Event-based methods reconstruct the patterns of ancestral distributions by explicitly incorporating all biogeographical processes into the analysis, rather than just focusing on vicariance (Sanmartín 2007). Each of these processes (vicariance, dispersal, extinction, and symmetric speciation) is associated with a cost that should be inversely related to its likelihood: the more likely the event, the lower the cost. Speciation is assumed to occur by vicariance, separating a wide distribution into two mutually exclusive set of areas and this costs nothing (0); a species occurring in a single area may speciate within the area by allopatric (or possibly sympatric) speciation giving rise to two descendants occurring in the same area: this costs nothing (0); dispersal costs one per unit area added to a distribution; and extinction costs one per unit area deleted from a distribution (Ronquist 1997). The optimal reconstruction is found by searching for the reconstruction that minimizes the total cost of the implied events (Ronquist 1998, 2002). Thus, the minimum-cost reconstruction is the most likely (most parsimonious) explanation for the origin of the pattern being analyzed. Because the optimality criterion being used is one of maximum parsimony, these methods are often called "event-based parsimony methods" (Sanmartín 2007).

Critiques against event-based methods are mostly based on the idea that if the costs assigned to each of the biogeographical processes considered are wrong, the biogeographical inference would be wrong; and that these approaches offer the possibility of an infinite combination of costs (Siddal & Kluge 1997, Grant & Kluge 2003, Posadas et al. 2006). Sanmartín (2007) points out that this argument has been used against model based methods, such as maximum likelihood or Bayesian inference in phylogenetic analysis. However, "by making explicit the connection between biogeographic processes and the distribution patterns they generate, event based methods can be used to compare alternative process models/biogeographic scenarios" (Sanmartín 2007).

DIVA requires a fully dichotomous tree of less than 180 taxa and allows the use of 15 areas to represent the distribution of the taxa. The DIVA analysis was performed on the phylogenetic hypothesis of the family Fanniidae proposed by Domínguez & Roig-Juñent (2008), which was based on morphological characters included 78 species representing the four genera of Fanniidae and all the species groups within the genus *Fannia*, except for the *admirabilis* group proposed by Albuquerque et al. (1981) and the *setifer* subgroup proposed by Chillcott (1961a). These terminal taxa were chosen by Domínguez & Roig-Juñent (2008) based on the classifications of the Fanniidae by Chillcott (1961a), Albuquerque et al. (1981), and Rozkošný et al. (1997). Domínguez & Roig-Juñent (2008) also included six undescribed species from New Zealand, which correspond to the adults of the larvae of Fanniidae described by Holloway (1985), and three recently described species from Argentina (Domínguez 2007). The out-groups used by Domínguez & Roig-Juñent (2008) were not included in the present biogeographical analysis because they are species that belong to very diverse families, and although they were useful to represent morphological aspects of these families, they are not so in a biogeographical context. The distributional ranges of the species included in this analysis (indicated in Appendix) were obtained from Chillcott (1961a, 1961b), Pont (1977, 1980), Albuquerque et al. (1981), Holloway (1985), Pont & Carvalho (1994), Rozkošný et al. (1997), Carvalho et al. (2003), Moore & Savage (2006), and Domínguez (2007).

In order to compare our results with previous hypotheses (Chillcott 1961a, Hennig 1965), and because of the widespread distribution of the family Fanniidae, we used large areas, each corresponding to historically persistent landmass according to palaeogeographic reconstructions (Cox 1974). The Holarctic was divided into three infraregions partially following Sanmartín et al. (2001): (A) including the eastern Nearctic defined as North America east of the former Mid Continental Seaway, and the western Nearctic or North America west of the Mid-Continental Seaway, both treated as a single area (North America, A) because most of the species of Fanniidae included in this analysis from this area are distributed in both eastern and western Nearctic (Chillcott 1961a); (B) the western Palaearctic, defined as Europe, North Africa and Asia west of the former Turgai Sea; and (C) the eastern Palaearctic as non tropical Asia east of the Turgai Sea.

For the Southern Hemisphere we have considered five areas in which the species of Fanniidae are present, based on Sanmartín & Ronquist (2004), excluding Madagascar, India, New Caledonia, and New

Guinea because no records of Fanniidae are known for these areas. The five southern areas included in this analysis are (D) Africa excluding the region north of the Saharan belt, because Sanmartín & Ronquist (2004) consider the sub-Saharan a single unit because the division between tropical and temperate regions is often not clear from the distribution of the terminal taxa in many of their study groups; (E) Australia and Tasmania; (F) New Zealand. South America was considered as formed by two areas, with independent biota (Crisci et al. 1991, Morrone 2001): (G) Patagonia, also called Southern South America or the Andean region, and (H) the Neotropical region.

North western Mexican distributions were considered as Nearctic, and tropical Mexico, together with all Caribbean islands, as part of the Neotropical region following Morrone (2001).

Widespread taxa (terminal taxa distributed in more than one area) pose a problem in biogeographic reconstructions because they introduce ambiguity in the data set (Morrone & Crisci 1995). This problem has traditionally been dealt with using the Assumptions 0, 1, and 2 of Nelson & Platnick (1981), but these assumptions are inapplicable to event-based methods (Sanmartín & Ronquist 2004). Therefore, we have included the complete distribution range of widespread species, leaving the method to indicate the ancestral areas.

We searched for the optimal distributions of the ancestral nodes using the “optimize” command; we did not constrain ancestral distributions allowing the

program to include all areas at each node (“maxareas” = 8); we did not set a minimum age for the deepest node in the tree; we allowed ambiguous optimal distributions to be included in the summary statistics of the program (“reset ambiguous”).

## RESULTS

A DIVA exact search resulted in 32800 alternative equally optimal reconstructions, each of which required 90 dispersals. All the optimal area reconstructions at each ancestral node are shown in Figs. 1 and 2. Fig. 1 shows the basal nodes of the tree and Fig. 2 the apical nodes.

Twenty-eight of the 77 nodes of the cladogram have ambiguous area assignments; nodes 153, 150, 140, 139, 113, 96 and 95 resulted in more than five possible reconstructions. The remaining 49 nodes resulted in unambiguous area assignments. Vicariance events are summarized in Table 1, and Table 2 shows dispersal between single areas.

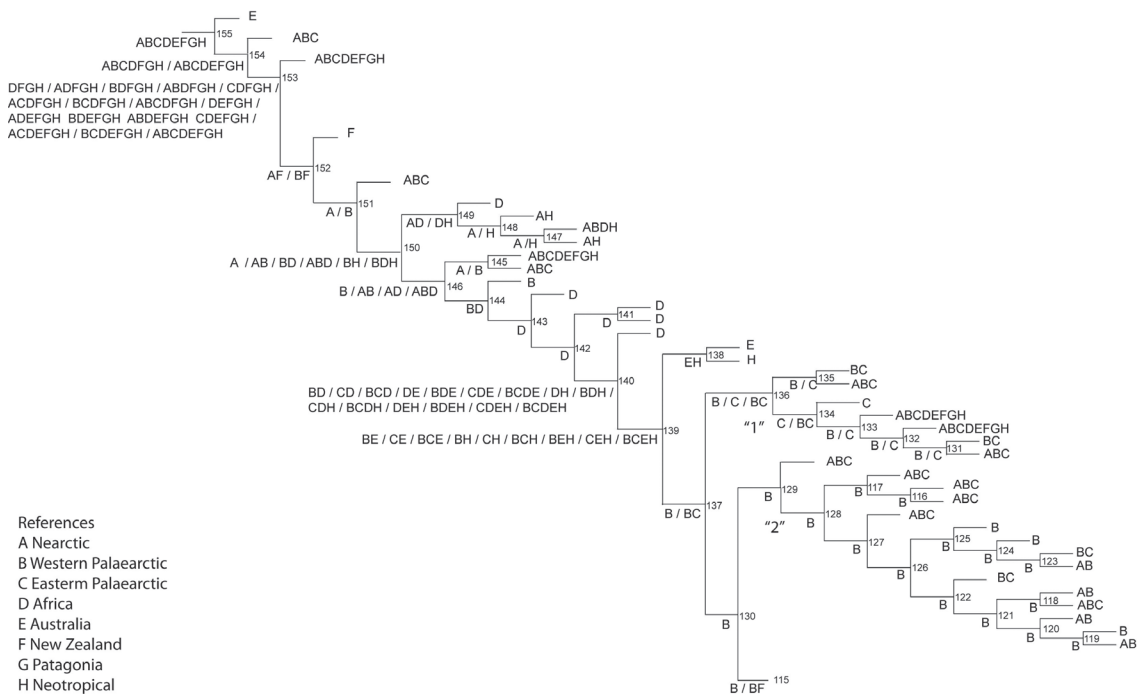

Fig. 1: Summary of optimal reconstructions of ancestral distributions of basal nodes of the cladogram based on a dispersal-vicariance analysis (DIVA). When more than one reconstruction is possible, alternative distributions are separated with “/”.

Resumen de las reconstrucciones de distribuciones ancestrales óptimas de los nodos basales del cladograma basado en un estudio de dispersión-vicarianza (DIVA). Cuando más de una reconstrucción es posible, las distribuciones alternativas están separadas por “/”.

The possible ancestral distributions obtained for the basal nodes (153-155) include all the regions present in this analysis (Fig. 1), as a single area at nodes 155 and 154 or in different combinations at node 153. The most frequent vicariance events at these nodes (153-155) are the separation of Australia (E) from all the remaining areas (Table 1); the separation of the Nearctic, the eastern and western Palaearctic regions (ABC) from Africa, Australia, New Zealand, Patagonia, and the Neotropics (DEFGH); and the separation of the Nearctic, the eastern and western Palaearctic regions (ABC) from Africa, New Zealand, Patagonia, and the Neotropics (DFGH) (Table 1).

Between nodes 141 and 152 the ancestral distributions are placed in the Nearctic (A),

the western Palaearctic region (B), Africa (D) and the Neotropics (H) in different combinations or isolated, except for node 152, which includes New Zealand (F) along with the Nearctic (A) and the western Palaearctic regions (B). At nodes 146 to 150 the most frequent vicariance event is the separation of the western Palaearctic regions from the Nearctic and Africa (B-AD). And at nodes 141 to 152 dispersion is assumed at node 147 from the Nearctic (A) or Neotropical region (H) to the western Palaearctic region and Africa (A-H→B,D); and at node 145 from the Nearctic (A) or the western Palaearctic region to all the remaining regions (A-B→C, D, E, F, G, H) in one terminal (corresponding to the cosmopolitan *F. canicularis*) and to eastern Palaearctic in the other (A-B→C) (Table 2).

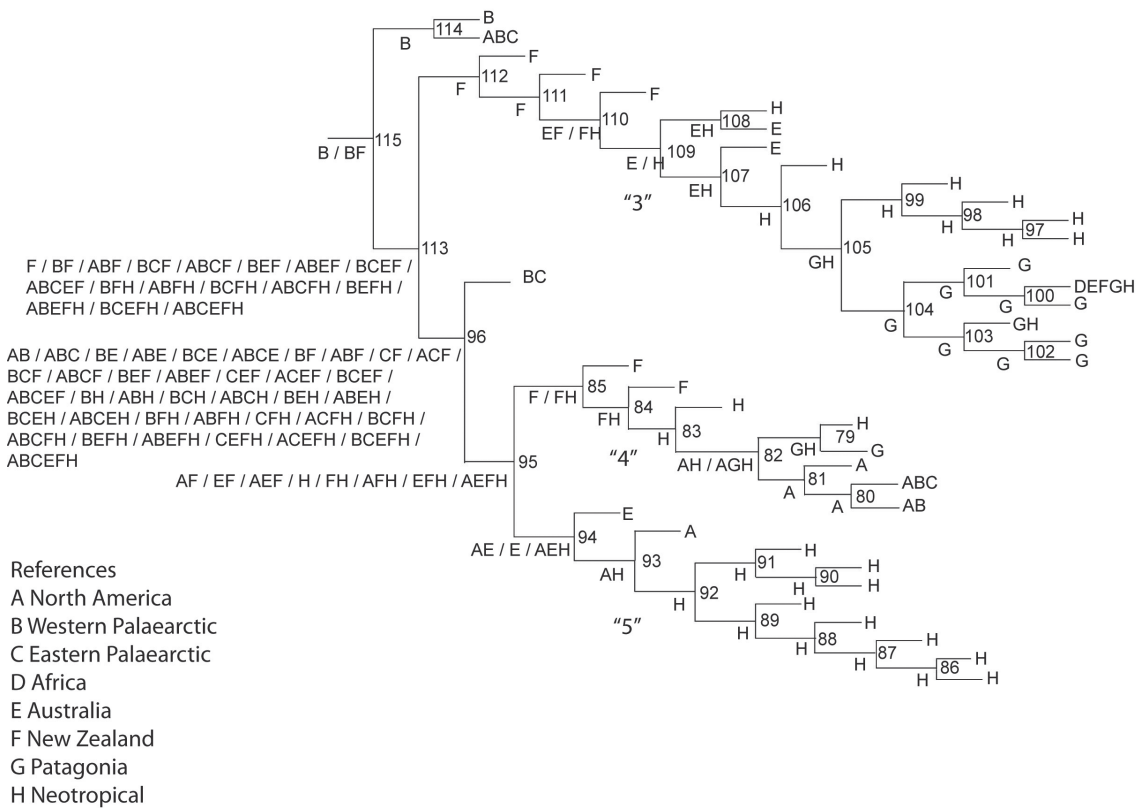

Fig. 2: Summary of optimal reconstructions of ancestral distributions of apical nodes of the cladogram based on a dispersal-vicariance analysis (DIVA). When more than one reconstruction is possible, alternative distributions are separated with “/”.

Resumen de las reconstrucciones de distribuciones ancestrales óptimas de los nodos apicales del cladograma basado en un estudio de dispersión-vicarianza (DIVA). Cuando más de una reconstrucción es posible, las distribuciones alternativas están separadas por “/”.

TABLE 1

Ancestral distribution assignment to each node, vicariance events, frequency of vicariance events, and shared vicariance events. Areas are referred to as A (North America), B (Western Palaearctic), C (Eastern Palaearctic), D (Africa), E (Australia), F (New Zealand), G (Patagonia), H (Neotropical).

Distribuciones ancestrales asignadas a cada nodo, eventos de vicarianza, frecuencia de eventos de vicarianza y eventos de vicarianza compartidos. Las áreas están representadas por A (América del Norte), B (Paleártico occidental), C (Paleártico Oriental), D (África), E (Australia), F (Nueva Zelanda), G (Patagonia), H (Neotropical).

Node	Distribution assignment	Vicariance event	Frequency	Shared with node:
79	GH			
80	A			
81	A			
82	AH			
	AGH	A-GH	511.500	
83	H			
84	FH			
85	F			
	FH			
86	GH			
87	H			
88	H			
89	H			
90	H			
91	H			
92	H			
93	AH			
94	AE			
	EH			
	AEH	E-AH	511.500	
95	AF			
	EF			
	AEF	AE-F	328.583	
	H			
	FH			
	AFH	F-AH	164.292	
	EFH	F-EH	328.583	
	AEFH	F-AEH	477.228	
96	AB			
	ABC	A-BC	62.587	
	BE			
	ABE	B-AE	31.294	
	BCE			
	ABCE	BC-AE	62.587	
	BF			
	ABF	B-AF	46.940	113
		AB-F	125.175	113
	CF			
	ACF	C-AF	15.647	

(Cont. Table 1)

Node	Distribution assignment	Vicariance event	Frequency	Shared with node:
96	BCF	BC-F	292.074	113
	ABCF	BC-AF	78.234	113
		ABC-F	62.587	113
	BEF	B-EF	62.587	113
		BE-F	156.468	113
	ABEF	B-AEF	39.117	113
	ABE-F	41.725	113	
	CEF	C-EF	20.862	113
	ACEF	C-AEF	7.823	113
	BCEF	BC-EF	104.312	113
		BCE-F	78.234	113
	ABCEF	BC-AEF	70.411	
		ABCE-F	20.862	
	BH			
	ABH	B-AH	20.862	139
	BCH	BC-H	231.515	
	ABCH	BC-AH	41.725	139
	BEH	B-EH	475.490	
	ABEH	B-AEH	20.862	139
	BCEH	BC-EH	379.870	
	ABCEH	BC-AEH	41.725	113
	BFH	B-FH	46.940	113
		F-BH	135.606	113
	ABFH	B-AFH	26.078	113
		F-ABH	31.294	
	CFH	C-FH	15.647	
	ACFH	C-AFH	5.216	113
	BCFH	BC-FH	78.234	113
		F-BCH	67.803	113
	ABCFH	BC-AFH	46.940	113
		F-ABCH	15.647	113
	BEFH	B-EFH	39.117	113
		F-BEH	41.725	113
	ABEFH	B-AEFH	23.470	113
		F-ABEH	10.431	
	CEFH	C-EFH	7.823	
	ACEFH	C-AEFH	2.608	113
	BCEFH	BC-EFH	70.411	113
		F-BCEH	20.862	113
	ABCEFH	BC-AEFH	44.333	113
		F-ABCEH	5.216	
97	H			
98	H			
99	H			
100	G			
101	G			
102	G			
103	G			
104	G			
105	GH			
106	H			
107	EH			
108	EH			

(Cont. Table 1)

Node	Distribution assignment	Vicariance event	Frequency	Shared with node:
109	E			
	H			
110	EF			
	FH			
111	F			
112	F			
113	F			
	BF			
	ABF	B-AF	46.940	96
		AB-F	125.175	96
	BCF	BC-F	292.074	96
	ABCF	BC-AF	78.234	96
		ABC-F	62.587	96
	BEF	B-EF	62.587	96
		BE-F	156.468	96
	ABEF	B-AEF	39.117	96
		ABE-F	41.725	96
	BCEF	BC-EF	104.312	96
		BCE-F	78.234	96
	ABCEF	BC-AEF	70.411	96
		ABCE-F	20.862	96
	BFH	B-FH	46.940	96
		F-BH	135.606	96
	ABFH	B-AFH	26.078	96
		F-ABH	31.294	96
	BCFH	BC-FH	78.234	96
		F-BCH	67.803	96
	ABCFH	BC-AFH	46.940	96
		F-ABCH	15.647	96
	BEFH	B-EFH	39.117	96
		F-BEH	41.725	96
113	ABEFH	B-AEFH	23.470	96
		F-ABEH	10.431	96
	BCEF	BC-EFH	70.411	96
		F-BCEH	20.862	96
	ABCEF	BC-AEFH	44.333	96
		F-ABCEH	5.216	96
114	B			
115	B			
	BF			
116	B			
117	B			
118	B			
119	B			
120	B			
121	B			
122	B			
123	B			
124	B			
125	B			
126	B			
127	B			
128	B			
129	B			

(Cont. Table 1)

Node	Distribution assignment	Vicariance event	Frequency	Shared with node:
130	B			
131	B			
	C			
132	B			
	C			
133	B			
	C			
134	C			
	BC			
135	B			
	C			
136	B			
	C			
	BC			
137	B			
	BC			
138	EH			
139	BE			
	CE			
	BCE	BC-E	231.515	
	BH			
	CH			
	BCH	BC-H	231.515	96
	BEH	B-EH	475.490	96
	CEH	C-EH	148.065	96
	BCEH	BC-EH	379.870	96
	BD			
140	CD			
	BCD	BC-D	63.457	
	DE			
	BDE	D-BE	169.218	
	CDE	D-CE	84.609	
	BCDE	D-BCE	42.304	
	DH			
	BDH	B-DH	155.757	
	D-BH	169.218		
	CDH	D-CH	84.609	
	BCDH	D-BCH	42.304	
	DEH	D-EH	105.761	
	BDEH	D-BEH	84.609	
	CDEH	D-CEH	42.304	
	BCDEH	D-BCEH	21.152	
141	D			
142	D			
143	D			
144	BD			
145	A			
	B			
146	B			
	AB			
	AD			
	ABD	A-BD	155.757	150
		B-AD	311.51	150
147	A			
	H			

(Cont. Table 1)

Node	Distribution assignment	Vicariance event	Frequency	Shared with node:
148	A			
	H			
149	AD			
	DH			
150	A			
	AB			
	BD			
	ABD	A-BD	155.757	
		B-AD	311.514	
	BH	B-DH		
	BDH	D-BH	155.757	
			169.218	
151	A			
	B			
152	AF			
	BF			
153	DFGH	F-DGH	35.694	
	ADFGH	A-DFGH	10.852	
		F-ADGH	30.036	
		AF-DGH	10.852	
	BDFGH	B-DFGH	13.083	
		F-BDGH	28.922	
		BF-DGH	13.083	
	ABDFGH	A-BDFGH	10.852	
		B-ADFGH	13.083	
		F-ABDGH	23.487	
		AF-BDGH	10.852	
		BF-ADGH	13.083	
	CDFGH	F-CDGH	35.694	
	ACDFGH	A-CDFGH	10.852	
		F-ACDGH	30.036	
		AF-CDGH	B10.852	
	BCDFGH	CDFGH	13.083	
		F-BCDGH	28.922	
		BF-CDGH	A-13.083	
	ABCDFGH	BCDFGH	66.081	154
		B-ACDFGH	68.760	154
		AB-CDFGH	C-162.963	154
		ABDFGH	AC-54.490	154
		BDFGH	BC-162.963	154
		ADFGH	162.963	154
		ABC-DFGH	381.696	154
		F-ABCDGH	23.487	154
		AF-BCDGH	10.852	154
		BF-ACDGH	F-13.083	154
	DEFGH	DEGH	71.389	
	ADEFGH	A-DEFGH	21.459	
		F-ADEGH	61.541	
		AF-DEGH	B21.459	
	BDEFGH	DEFGH	25.515	
		BF-DEGH	59.488	
		F-BDEGH	25.515	
	ABDEFGH	A-BDEFGH	21.459	
		B-ADEFGH	25.515	

(Cont. Table 1)

Node	Distribution assignment	Vicariance event	Frequency	Shared with node:
153		BF-ADEGH	48.562	
		AF-BDEGH	21.459	
		F-ABDEGH	5.515	
	CDEFGH	F-CDEGH	71.389	
	ACDEFGH	AF-CDEGH	21.459	
		F-ACDEGH	61.541	
		A-CDEFGH	21.459	
	BCDEFGH	B-CDEFGH	25.515	
		BF-CDEGH	59.488	
		F-BCDEGH	25.515	
	ABCDEFHGA	ABCDEFHGA	49.491	154-155
		B-ACDEFHGA	54.091	154-155
		AB-CDEFHGA	82.499	154-155
		BF-ACDEGH	27.720	154-155
		AC-BDEFHGA	25.515	154-155
		BC-ADEFHGA	82.499	154-155
		ABC-DEFHGA	230.504	154-155
		E-ABCDEFHGA	511.500	154-155
		F-ABCDEFHGA	48.562	154-155
		AF-BCDEGH	21.459	154-155
		C-ABDEFHGA	82.499	154-155
154	ABCDFGH	A-BCDFGH	66.081	153
		B-ACDFGH	68.760	153
		AB-CDFGH	C162.963	153
		ABDFGH	AC54.490	153
		BDFGH	BC162.963	153
		ADFGH	162.963	153
		ABC-DFGH	381.696	153
		F-ABCDGH	23.487	153
		AF-BCDGH	10.852	153
		BF-ACDGH	13.083	153
	ABCDEFHGA	ABCDEFHGA	49.491	153-155
		B-ACDEFHGA	54.091	153-155
		AB-CDEFHGA	82.499	153-155
		BF-ACDEGH	27.720	153-155
		AC-BDEFHGA	25.515	153-155
		BC-ADEFHGA	82.499	153-155
		ABC-DEFHGA	230.504	153-155
		E-ABCDEFHGA	511.500	153-155
		F-ABCDEFHGA	48.562	153-155
		AF-BCDEGH	21.459	153-155
		C-ABDEFHGA	82.499	153-155
155	ABCDEFHGA	ABCDEFHGA	49.491	153-154
		B-ACDEFHGA	54.091	153-154
		AB-CDEFHGA	82.499	153-154
		BF-ACDEGH	27.720	153-154
		AC-BDEFHGA	25.515	153-154
		BC-ADEFHGA	82.499	153-154
		ABC-DEFHGA	230.504	153-154
		E-ABCDEFHGA	511.500	153-154
		F-ABCDEFHGA	48.562	153-154
		AF-BCDEGH	21.459	153-154
		C-ABDEFHGA	82.499	153-154



TABLE 2

Frequency of dispersal events between two areas. Areas are referred to as A (North America), B (Western Palaearctic), C (Eastern Palaearctic), D (Africa), E (Australia), F (New Zealand), G (Patagonia), H (Neotropical).

Frecuencia de las dispersiones entre dos áreas. Las áreas están representadas por A (América del Norte), B (Paleártico occidental), C (Paleártico Oriental), D (África), E (Australia), F (Nueva Zelanda), G (Patagonia), H (Neotropical).

From	→	To	Frequency
B	→	A	511.500
A	→	H	511.500
B	→	D	54.764
B	→	E	157.310
B	→	F	511.500
B	→	H	511.500
C	→	B	511.500
C	→	E	511.500
C	→	H	84.319
D	→	A	511.500
D	→	B	240.076
D	→	C	511.500
D	→	E	21.152
D	→	H	21.152
E	→	A	155.757
E	→	B	409.583
E	→	C	126.913
E	→	F	211.522
E	→	H	367.279
F	→	A	54.764
F	→	B	63.457
F	→	C	21.152
H	→	F	46.940
F	→	H	511.500
G	→	H	489.115
H	→	A	511.500
H	→	B	33.901
H	→	C	511.500
H	→	D	511.500
H	→	E	511.500
H	→	G	511.500
F	→	E	63.457
A	→	B	21.152
A	→	D	55.757
A	→	E	511.500
A	→	F	93.881
B	→	C	511.500

The ancestral distribution of node 140 is placed in different combination of the western Palaearctic region (B), the eastern Palaearctic region (C), Africa (D), Australia (E) and the Neotropics (H) (Fig. 1). The same regions have been assigned as ancestral to node 139, excluding Africa (D) (Fig. 1). The most frequent vicariance events at node 140 are: the separation of the western Palaearctic region from Africa and the Neotropics (B-DH), and the separation of the western Palaearctic region from Africa and the Neotropical region (B-DH) (Table 1). At node 139 the most frequent vicariance events are the separation of the western Palaearctic and eastern Palaearctic regions from the Neotropical regions (BC-H); the western Palaearctic from Australia and the Neotropical region (B-EH) and the separation of the the western and eastern Palaearctic regions from Australia and the Neotropical region (BC-EH).

Ancestral distributions of nodes 131 to 138 are placed in both the western and eastern Palaearctic regions, or in one of these regions separately, except for node 138 that has an Australian/Neotropical ancestor. Among nodes 131 to 136 dispersions are assumed between the eastern and western Palaearctic regions (BC) to the Nearctic (A) and to all the remaining regions, in the terminals that corresponds to the cosmopolitan *F. scalaris* and *F. incisurata* (Table 2).

Ancestral distributions of nodes 116 to 130 are placed exclusively in the western Palaearctic region (B) and dispersions are assumed from this region (B) towards the eastern Palaearctic region (C) and Asia and the Nearctic (A) (Fig. 1, Table 2).

Nodes 113 and 96 (Fig. 2) present in ambiguous ancestral distributions, these are placed in all the areas considered in this analysis except for Patagonia (G) and Africa (D). Node 113 contains two clades: a first clade with ancestral distributions in Australia (E), New Zealand (F), Patagonia (G), and the Neotropics (H), and a second clade with ancestral distributions in the Nearctic (A) Australia (E), New Zealand (F), and the Neotropics (H).

Nodes 113 and 96 (Fig. 2) show a high number of possible reconstructions and consequently of possible vicariance events (Fig. 2, Table 1). At node 113 (Fig. 2) the most

frequent vicariance event is the separation of the western and eastern Palaearctic regions from New Zealand (BC-F) (Table 1). Node 96 also shows this vicariance event (the separation of the western and eastern Palaearctic (BC) regions from New Zealand (F)) in the same frequency (Table 1); but two other vicariance events are more frequent: the separation of the western Palaearctic region from Australia and the Neotropics (B-EH), and the separation of the western and eastern Palaearctic regions from Australia and the Neotropics (BC-EH).

In the portion of the tree containing nodes 79 to 96, dispersions from Australia (E), New Zealand (F) and the Neotropics (H) to the Nearctic region (A) are assumed when this area (A) is not included in the ancestral distribution. For example, at node 94 one of the options, among the three ambiguous distributions proposed, is Australia and Neotropics (EH); therefore, in order to explain the inclusion of the Nearctic region in the ancestral distribution of node 93, the program assumes a dispersion. But when any of the other two possible reconstructions are considered, that is the Nearctic and Australia (AE), or the Nearctic, Australia and the Neotropics (AEH), the presence of (A) in the ancestral distribution of node 93 is explained by a vicariance event.

#### DISCUSSION

Our analysis shows an ancestor of the Fanniidae widely distributed over different regions of the world (Fig. 1). The basal nodes of the tree are placed in all the regions considered in the analysis. This could be avoided, by constraining ancestral distributions, not allowing the program to include all areas in the alternative ancestral distributions at each node (using the "maxareas" command). However, we have not done so because it would have resulted in different combinations of all areas included. Ronquist (1996) warns that this "primitive cosmopolitanism" is a pitfall in dispersal vicariance analysis, and that the state at the root node is the least reliable of the entire tree.

Furthermore, Cranston (2005) points out that many recent dipteran families are globally distributed at present, and it is therefore

tempting to argue for past Pangeic distributions, but present day "Pangeic" distributions may reflect only the effects of subsequent stochastic intra-hemispheric dispersal. Nevertheless, according to Cranston (2005), the existence of higher taxon sister clades, each restricted to one of the major Jurassic land masses of Laurasia and Gondwana may reflect deep historical association with the sundering Pangea. Cranston (2005) mentions examples of this distribution among the Anisopodoidea (Amorim & Tozoni 1994), the Chironomidae (Brundin 1966) and the Apioceridae and Mydidae (Yeates & Irwin 1996).

Our analysis shows two apical sister groups with disjoint distributions: a clade with species occurring only in the Holarctic region (Fig. 1, node 137), and a clade which groups mostly all species of the Neotropical, Australian, and New Zealand region (Fig. 2); and vicariance events throughout nodes 139 to 155 (Table 1) that support the association between the pattern in this portion of the Fanniidae tree and the division of the Pangea.

If this vicariance event (i.e. the separation of the Laurasic and Gondwanic fauna), is considered as a reference, an older age than that previously proposed for this family can be estimated.

Hennig (1965) proposed that the family Fanniidae could belong to the Upper Cretaceous. Hennig's (1965) estimation of this age was based on his proposals for the age of faunal interchange between North and South America and on the sister group relationship between Fanniidae and Muscidae. Hennig (1965), following Chillcott (1961a), proposed that the Neotropical Region may have been colonized by four clades of fanniids from the Holarctic region, in two immigration stada: one thought to have taken place in the late Cenozoic or between the Cenozoic and the Cretaceous (edentate strata), and a second in the Pliocene or late Miocene. Therefore, according to Hennig (1965) the family must have been present in the upper Cretaceous. Furthermore, Hennig (1965) considered that being Fanniidae the sister group of Muscidae, both groups must be of the same age, that he estimated to be upper Cretaceous.

Very few biogeographical studies have dealt with the history of the higher Diptera,

and most proposals are contradictory, offering very different hypotheses regarding the age of the Schizophora. According to Grimaldi & Cumming (1999) the first fossil evidence for the Schizophora is from Eocene Baltic amber (Hennig 1965), which contains muscoids considered primitive at generic levels, and therefore Grimaldi & Cumming (1999), based in fossil evidence, consider that the radiations of the Schizophora are Cenozoic and that definitive calyptrates did not appear until de Cenozoic. Nevertheless, Amorim & Silva (2002) indicate that when assessing the age of Diptera groups, palaeontology and biogeography correspond to two sources of evidence with incongruent results: the age of origin of groups proposed based on vicariant biogeographical methods is much older than that indicated by palaeontological evidence. The difference may be due to the fact that fossil records provide a minimal age for a group but can not deny it existed before (Amorim & Silva 2002). On the other hand, vicariance-based estimates suggest absolute ages, because they are linked to process-related events (Lundberg 1998, Nihei & Carvalho 2004).

Our results indicate that the family could have a Pangeic origin, and therefore could have been present in Late Jurassic or early Cretaceous times, when the separation of the Gondwanan landmasses began (Pitman et al. 1993). The same pattern has been found in the family Muscidae that is one of the few families of higher Diptera (along with Anthomyiidae) for which historical biogeographical hypothesis have been proposed. Couri & Carvalho (2003) in a study of the systematic relations among *Philornis* Meinert, *Passeromyia* Rodhain & Villeneuve and allied genera suggest an older age than the upper Cretaceous origin proposed by Hennig (1965) for the Muscidae; Couri & Carvalho (2003) point out that the species among the genera of Renwarditiinae and of a monophyletic group within the Dichaetomyiinae subfamily show a distributional pattern that resembles a Gondwanan pattern, suggesting that the ancestor of these genera could have appeared before the upper Cretaceous. Another example of higher diptera that could be placed in this time frame is the genus *Coenopsia* Malloch (Anthomyiidae); in a taxonomic, cladistic, and

biogeographic analysis of this genus Nihei & Carvalho (2004) discussed that a Gondwanan origin could be a competing hypothesis, along with the North to South dispersal proposed by Michelsen (1991) to explain the origin of the family Anthomyiidae.

Chillcott (1961a) proposed that the great diversity of species of the Palaearctic region indicated that this area contained the centre of origin of the family, and that faunal interchange occurred, from very early times, with the Nearctic region across the Beringian land bridge, and from the holarctic region to South America. And as mentioned before Hennig (1965) also assumed a holarctic origin for the family. Our analysis shows the existence of two distinct clades that correspond to the two mayor landmasses that formed the Pangea allows the proposal of a new hypothesis of the biogeographic history of the family. The South American, as well as the Australian and New Zealand species of Fanniidae could have originated in the Gondwanan landmasses and therefore their distribution could be explained on the basis of the Gondwanan fragmentation scheme instead of the north to south migrations waves proposed by Chillcott (1961a) and Henning (1965). The holarticist view of Chillcott (1961a) and Hennig (1965) can be in part explained because many species of Fanniidae from Australia and New Zealand, and many Neotropical were not known to these authors.

In our analysis, most of the species of Fanniidae distributed in the Nearctic and in the eastern and western Palaearctic regions (nodes 116-136) are grouped in two clades: in one clade (clade "1") the ancestral distributions are placed in different combinations of the eastern and western Palaearctic regions, and in the other clade (clade "2") all ancestral distributions are placed in the western Palaearctic region.

Cranston (2005) in a review of biogeographic patterns in the evolution of Diptera points out that in contrast to the striking patterns found in many groups of Diptera from the southern hemisphere that show an association with the fragmentation of Gondwana, northern hemisphere patterns tend to be more complex and difficult to interpret. According to Sanmartín & Ronquist (2001) this may be because the large landmasses that

form the Holarctic region may have been in contact in numerous ways, and in different time periods, creating a reticulate pattern; or because the northern biota derives from stochastic recolonization processes following the disruption caused by the Pleistocene glaciations (Cranston 2005). Another problem, also mentioned by Cranston (2005) is that in many groups of Diptera northern taxa tend to be distributed widely across the Palaearctic and Nearctic regions, which is the case in the holarctic species of Fanniidae included here.

The assignment of the western Palaearctic region as the ancestral area in clade 2 is therefore questionable, although not in terms of costs in the sense of the amount of dispersals considered by the program as being most parsimonious but in a biogeographic sense.

The following hypothetical cases (Figs. 3A, 3B and 3C) show the optimizations given by DIVA 1.1 for different situations where terminals are distributed in more than one area, and illustrate the problems that arise when analyzing with DIVA a phylogeny with a large number of paralogous areas. In the first hypothetical case (Fig. 3A) we assume that all terminals are distributed in three areas which we have named C, D, and E. In this example, when all areas are present in equal number (five), DIVA 1.1 gives three equally parsimonious reconstructions, all of which involve a vicariance event at the base of the cladogram (C-DE; D-CE; CD-E), and dispersals from either C, D or E towards the remaining two areas. For example, it is equally parsimonious to assume dispersals from C to D and E, or from D to C and E. In Fig. 3B, terminals are distributed in all three areas as in the anterior hypothetical case, except for one terminal which is distributed in areas D and E (not in C). In this case DIVA 1.1 gives two equally parsimonious reconstructions, which also involve a vicariance event at the base (the separation of either CE from D or CD from E), assuming dispersal from either D or E to the remaining two areas. It is important to note that in this case, the number of "C" = 4, "D" = 5, and "E" = 5. It seems therefore to be more parsimonious for the program to assume dispersals from the most numerous terminal areas, than to assume a single extinction of area C. In Fig. 1, at nodes 131 to 131 this example explains the ancestral distribution

assignments: all three terminals have the same number of "B" and "C", and therefore these two areas are assigned as ancestral to the three nodes, and all the other areas present in the terminals are explained through dispersion. The third hypothetical case (Fig. 3C) shows terminals distributed in all regions except for one terminal which is only present in D. In this case DIVA 1.1 gives only one most parsimonious solution, which involves a vicariance event at the base that separates D from CE and dispersals in the following nodes from D, to the remaining areas. The remaining two examples (Figs. 3D and 3E) have a similar node assignment as Fig. 3C, and show that the program will assign the most numerous areas present in terminals, in this case area D, assuming a vicariance event at the base and dispersals towards the remaining areas of the cladogram.

The results in the clade that includes nodes 116 to 136, of our analysis are therefore incongruent with most biogeographic hypotheses for the northern hemisphere. According to Cranston (2005) the most commonly observed track followed by northern hemisphere Diptera is the trans-Atlantic track, elaborated by Matile (1988) for Keroplatidae (Mycetophiloidea), which has been placed in the Eocene/Oligocene. Nevertheless, Chillcott (1961a) and Hennig (1965) in their historical biogeographical hypotheses for the Fanniidae proposed that the faunal interchange between the Palaearctic region and the Nearctic occurred in the late Cenozoic or between the Cenozoic and the Cretaceous (edentate strata) and in the Pliocene or late Miocene across the Beringian land bridge. Congruent beringian patterns link East Asia with non-glaciated, northwestern Nearctic and were first identified among currently boreal insects (Cranston 2005). Tangelder (1988) proposed that in the Tipulid *Nephrotoma dorsalis* group the interactions between the Palaearctic and Nearctic involved Beringia, as well as in the simuliid genus *Gymnomyias* (Wood 1978) and in anthomyiid genus *Strobilomyia* (Michelsen 1988) (Cranston 2005). Furthermore, with regard to the ancestral area resulting in our analysis, Gaimari & Irwin (2000) proposed that three separate clades of the Therevid tribe Cyclotelini migrated from Asia through Beringia, making the western Palaearctic region (Asia) a more

realistic assignment to the nodes that group the holarctic species of Fanniidae. Nevertheless, in this scenario we would have obtained a high frequency of dispersions from the western Palaearctic region to the Nearctic region (A), which is not the case in this study (Table 2).

On the other hand, the representatives of Fanniidae distributed in the southern hemisphere show a pattern of vicariance and dispersal concordant with an orderly sequence of fragmentation of Gondwana. There are numerous examples of distributional patterns among Dipteran taxa that show an evident Gondwanic origin (see Cranston 2005).

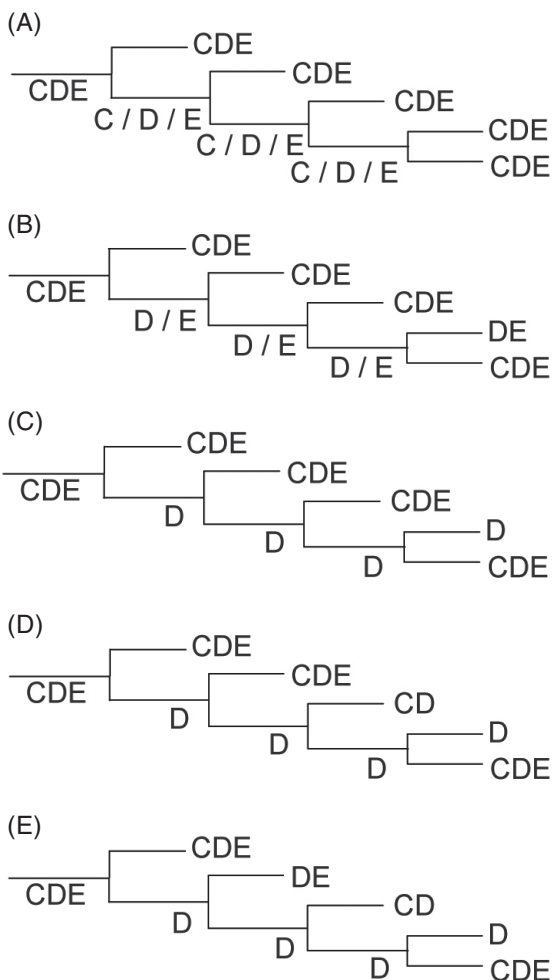

*Figs 3:* Hypothetical cases, in which the terminals occupy three areas in different combinations, that show ancestral distributions given by the program DIVA 1.1.

Casos hipotéticos en los cuales los terminales ocupan diferentes combinaciones de tres áreas y que muestran las distribuciones ancestrales dadas por el programa DIVA 1.1.

Fig. 2, at node 112 (clade 3) shows a first separation of New Zealand from a centre of origin situated in the Nearctic (A), eastern and western Palaearctic (B, C), Australia (E) New Zealand (F), Neotropics, followed by the separation of Australia (E) and the Neotropics (H). In the apical portion of this clade, the separation Patagonia (G) or the Andean region from a centre of origin situated in Neotropics and Patagonia (GH) from a centre of origin situated in the Neotropics and Australia. A similar pattern is found at node 85 (clade 4), that shows a first separation of New Zealand, and the subsequent separation of Australia and the Neotropics. This pattern, and more importantly the absence of South African representatives, fits into what Matile (1990) termed the “anphinotic track”, and involves cool temperate areas. The connection of New Zealand with Antarctica was through Marie Bird Land prior to the subsidence of the Campbell Plateau, in the late Cretaceous (Zinsmeister 1987). New Zealand began its drift away from the Australian-Antarctic margin of Gondwana (Flemming 1975), and became progressively more isolated about 82 million years ago (Flemming 1975, Cooper & Millener 1993), while Australia, Antarctica, and South America remained in contact until the Eocene, about 56 million years ago (Flemming 1975, Drinnan & Crane 1989). This fact could explain why many taxa from South America have sister groups among taxa distributed in Australia and just a few groups are confined to New Zealand and southern South America, but absent from Australia (Watt 1975). Several groups of Diptera show this pattern such as the genus *Cnephia* Prosimuliini (Davies & Györkös 1988, Crosskey 1990, Coscarón & Coscarón-Arias 1998, Roig-Juñent & Coscarón 2001), many Mycetophiloidea (Munroe 1974, Matile 1990, Amorim & Pires 1996), Scatopsidae (Amorim 1989), Canthylloscelidae (Hennig & Wygodzinsky 1966, Amorim 2000) and Chironomidae (Brundin 1966).

Clade 5 (node 94) in Fig. 2, shows a first separation of Australia from either North America and Australia (AE), or Australia and the Neotropics (EH), or from all three areas (North America, Australia, the Neotropics). Furthermore, clade 4 also shows ancestral distributions in North America. This pattern could better fit into what Matile’s (1990)

tropical gondwanan track, because numerous species of Fanniidae of Gondwanic origin are presently distributed in tropical regions (e.g., *F. bella* Albuquerque, *F. bahiensis* Albuquerque from Brazil) and because the tropical Gondwanan track includes what Matile (1990) termed “recent extensions” into the Holarctic regions. Examples of this pattern are found in the Lygistorrhinidae (Sciaroidea) and in the Anisopodidae (Amorim & Pires 1996). The dispersion of representatives of Gondwanan fauna to the Holarctic region could indicate that the faunal interchange between North and South America may have occurred from South America to North America, contrary to the North-South direction proposed by Chillcott (1961a) and Hennig (1965). Nevertheless, which of the faunal elements in each continent were there since continents were connected and which arrived afterwards, the age of this family and its relationship to Pangea, the relationship between the Laurasic and Gondwanan fauna and biogeographic events occurring in these landmasses are questions that also apply to other groups of animal and plants. The addition of more distributional information, a better comprehension of available fossils, as well as the comparison of phylogenetic studies of this and other families of Diptera would surely allow a better understanding of these questions.

ACKNOWLEDGEMENTS: This project was supported by Consejo Nacional de Investigaciones Científicas y Técnicas (Argentina) through the following grant: PIP #112-200801-01869; CONICET for doctoral and postdoctoral fellowships to M.C.D.; “Fundación Antorchas” and the British Council for an Award for advanced studies in the U. K. to M.C.D.; and Dr. Adrian C. Pont for sharing his knowledge on Fannid Taxonomy. We are also very grateful to Néida Horak for her help with the English.

#### LITERATURE CITED

- ALBUQUERQUE DDO, D PAMPLONA & CJB CARVALHO (1981) Contribuição ao conhecimento dos *Fannia* R.D., 1830 da região neotropical (Diptera, Fanniidae). Archivos do Museo Nacional Rio de Janeiro 56: 9-34.
- AMORIM DS (1989) A new species of the genus *Diamphidicus* cook (Diptera: Bibionimorpha, Scatopsidae) from Chile. Revista Brasileira de Entomologia 33: 477-482.
- AMORIM DS (2000) A new Phylogeny and phylogenetic classification for the Canthyloscelidae (Diptera: Psicomorpha). Canadian Journal of Zoology 78: 1067-1077.
- AMORIM DS & MRS PIRES (1996) Neotropical biogeography and a method for maximum biodiversity estimation. In: Bicudo CEM & NA Menezes (eds) Biodiversity in Brazil: A first approach: 183-219. CNPq, San Paulo.
- AMORIM DS & VC SILVA (2002) How far advanced was Diptera evolution in the Pangea? Annales de la Société Entomologique de France 38: 177-200.
- AMORIM DS & SHS TOZONI (1994) Phylogenetic and biogeographic analysis of the Anisopodidae (Diptera: Biobionimorpha) with an area cladogram for intercontinental relationships. Revista Brasileira de Entomologia 38: 517-543.
- BRUNDIN L (1966) Transantarctic relationships and their significance, as evidenced by chironomid midges with a monograph of the subfamilies Podonominae and Aphroteniinae and the austral Heptagyiidae. Kungliga Svenska Vetenskapsakademiens Handlingar 11: 1-472.
- CARVALHO CJB, AC PONT, MS COURI & D PAMPLONA (2003) A catalogue of the Fanniidae (Diptera) of the Neotropical Region. Zootaxa 219: 1-32.
- CHILLCOTT JG (1961a) A revision of the Nearctic species of Fanniinae (Diptera: Muscidae). The Canadian Entomologist Suppl. 14: 1-295.
- CHILLCOTT JG (1961b) Ten new species of *Fannia* R.-D. (Diptera: Muscidae) from the Palaearctic and Oriental regions. The Canadian Entomologist 93: 81-92.
- COOPER RA & MILLENER PR (1993) The New Zealand biota. Historical background and new research. Trends in Ecology and Evolution 8: 429-433.
- COSCARÓN S & CL COSCARÓN-ARIAS (1998) Simuliidae. In: Morrone JJ & S Coscarón (eds) Biodiversidad de artrópodos argentinos: 304-313. Ediciones Sur, La Plata, Argentina.
- COURI MS & CJB CARVALHO (2003) Systematic relations among *Philornis* meinert, *Passeromyia* Rodhain & Villeneuve and allied genera (Diptera, Muscidae). Brazilian Journal of Biology 63: 223-232.
- COX CB (1974) Vertebrate palaeodistributional patterns and continental drift. Journal of Biogeography 1: 75-94.
- CRANSTON P (2005) Biogeographic patterns in the evolution of Diptera. In: Yeates DK & BM Wiegmann (eds) The evolutionary biology of flies: 274-311. Columbia University Press, New York.
- CRAW R (1982) Phylogenetics, areas, geology and the biogeography of Croizat: A radical view. Systematic Zoology 31: 304-316.
- CRISCI JV, MM CIGLIANO, JJ MORRONE & SA ROIG-JUNENT (1991) Historical Biogeography of Southern South America. Systematic Zoology 40: 152-171.
- CROIZAT L, G NELSON & DE ROSEN (1974) Centres of origin and related concepts. Systematic Zoology 23: 265-287.
- CROSSKEY RW (1990) The Natural History of Blackflies. John Wiley and Sons Ltd., Chichester, UK.
- DARLINGTON PJ (1965) Biogeography of the southern end of the World. Distribution and history of far southern life and land, with an assessment of continental drift. Harvard University Press, Cambridge MA.

- DAVIES DM & H GYÖRKÖS (1988) Two new Australian species of Simuliidae (Diptera). *Journal Australian of Entomological Society* 27: 105-115.
- DOMÍNGUEZ MC (2007) A taxonomic revision of the southern South American species of the genus *Fannia* Robineau-Desvoidy (Diptera: Fanniidae). *Papeís Avulsos de Zoología* 47: 289-347.
- DOMÍNGUEZ MC & FH ABALLAY (2008) A new species of the genus *Fannia* Robineau-Desvoidy (Diptera: Fanniidae) collected on pig carrion in Mendoza, Argentina. *Annales Zoologici* 58: 819-824
- DOMÍNGUEZ MC & SA ROIG-JUÑENT (2008) A phylogeny of the family Fanniidae Schnabl (Insecta: Diptera: Calyptratae) based on morphological characters, with special reference to the austral species of the genus *Fannia*. *Invertebrate Systematics* 22: 563-587.
- DRINNAN AN & PR CRANE (1989) Cretaceous paleobotany and its bearing on the biogeography of austral angiosperms. In: Taylor TN & EL Taylor (eds) *Antarctic paleobiology. Its role in the reconstruction of Gondwana*: 192-219. Springer, New York.
- FLEMMING CA (1975) The geological history of New Zealand and its biota. In: Kuschel G (ed) *Biogeography and ecology in New Zealand*: 1-86. Dr. W. Junk, The Hague.
- GAIMARI SD & ME IRWIN (2000) Phylogeny, classification, and biogeography of the cycloteline Therevinae (Insecta: Diptera: Therevidae). *Zoological Journal of the Linnean Society* 129: 129-240.
- GRANT T & A KLUGE (2003) Data exploration in phylogenetic inference: Scientific, heuristic, or neither. *Cladistics* 19: 379-418.
- GRIMALDI D & J CUMMINGS (1999) Brachyceran Diptera in Cretaceous ambers and Mesozoic diversifications of the Eremoneura. *Bulletin of the American Museum of Natural History* 239: 1-124.
- HEADS M (1999) Vicariance biogeography and terrane tectonics in the South Pacific: Analysis of the genus *Abrotanella* (Compositae). *Biological Journal of the Linnean Society* 67: 391-432.
- HENNIG W & P WYGODZINSKY (1966) The Diptera fauna of New Zealand as a problem in systematics and zoogeography. *Pacific Insects Monograph* 9: 1-81.
- HENNIG W (1965) Vorarbeiten zu einem phylogenetischen system der Muscidae (Diptera: Cyclorrhapha). *Stuttgarter Beiträge zur Naturkunde* 141: 1-100.
- HOLLOWAY BA (1985) Larvae of New Zealand Fanniidae (Diptera: Calyptrata). *New Zealand Journal of Zoology* 11: 239-257.
- HUMPHRIES CJ (2001) Vicariance biogeography. In: Levin S (ed) *Encyclopedia of biodiversity*. Vol 5: 676-779. Academic press, San Diego, CA.
- LUNDBERG JG (1998) The temporal context for the diversification of Neotropical fishes. In: Malabarba LR, RE Reis, RP Vari, ZMS Lucena & CAS Lucena (eds) *Phylogeny and classification of Neotropical fishes*: 49-68. EDIPUCRS, Porto Alegre.
- MATILE L (1990) Recherches sur la systématique et l'évolution des Keroplatidae (Diptera: Mycetophiloidae). *Memoirs du Museum National d'Histoire Naturelle (France)*. Nouvelle Serie. Serie A. *Zoologie* 148: 1-682.
- MAZZA S & HR ORIBE (1939) Miasis urinaria por *Fannia fusconata* Rondani, en Formosa. In: *Investigaciones sobre dipteros argentinos*: 66-69. I Miasis. Publicaciones Misión de Estudios de Patología Regional Argentina, Jujuy.
- MICHELSSEN V (1988) A world revision of the genus *Strobilomyia* new genus and the anthomyiid seed pests of conifers (Diptera: Anthomyiidae). *Systematic Entomology* 13: 271-314.
- MICHELSSEN V (1991) Revision of the aberrant New World genus *Coenosopsia* (Diptera: Anthomyiidae), with a discussion of anthomyiid relationships. *Systematic Entomology* 16: 85-104.
- MOORES A & J SAVAGE (2005) A taxonomic revision of *Piezura* Rondani (Diptera: Fanniidae). *Zootaxa* 1096: 41-59.
- MORRONE JJ (2001) *Biogeografía de América Latina y el Caribe*. Volumen 3. M y T- Manuales & Tesis SEA. Sociedad Entomológica Aragonesa, Zaragoza.
- MORRONE JJ & J CRISCI (1995) Historical biogeography: Introduction to methods. *Annual Review of Ecology and Systematics* 26: 373-401.
- MUNROE DD (1974) The systematics, phylogeny, and zoogeography of *Symmerus* Walker and *Australosymmerus* Freeman (Diptera: Mycetophilidae: Ditomyiinae). *Memoirs of the Entomological Society of Canada* 92: 1-183.
- NELSON G & NI PLATNICK (1981) *Systematics and biogeography: Cladistics and vicariance*. Columbia University Press, New York.
- NIHEI SS & CJB CARVALHO (2004) Taxonomy, cladistics and biogeography of *Coenosopsia* Malloch (Diptera, Anthomyiidae) and its significance to the evolution of anthomyiids in the Neotropics. *Systematic Entomology* 29: 260-275.
- OLIVA A (1997) Insectos de interés forense de Buenos Aires (Argentina). Primera lista ilustrada y datos bionómicos. *Revista del Museo de Ciencias Naturales "Bernardino Rivadavia" e Instituto Nacional de Investigaciones de las Ciencias Naturales, Entomología (Argentina)* 7: 13-59.
- PITMAN WC, S CANDE, J LABRECQUE & J PINDELL (1993) Fragmentation of Gondwana: The separation of Africa and South America. In: Goldblatt P (ed) *Biological relationships between Africa and South America*: 15-34. Yale University Press, New Haven.
- PONT AC (1977) A revision of Australian Fanniinae (Diptera: Calyptrata). *Australian Journal of Zoology Supplement* 51: 1-60.
- PONT AC (1980) Family Fanniidae. In: Crosskey RW (ed) *Catalog of the Diptera of the Afrotropical Region*: 719-720. British Museum (Natural History), London.
- PONT AC & CJB CARVALHO (1994) Neotropical Fanniidae (Diptera): A key to the *Fannia anthracina*-group. *Entomologist's Monthly Magazine* 130: 229-238.
- POSADAS P, JV CRISCI & L KATINAS (2006) Historical biogeography: A review of its basic concepts and critical issues. *Journal of Arid Environments* 66: 389-403.
- QUIROGA NI & MC DOMÍNGUEZ (2010) A new species of the genus *Fannia* Robineau-Desvoidy (Diptera: Fanniidae) belonging to the *canicularis* species group, collected on pig carrion in the Yungas of the province of Jujuy, Argentina. *Studies on Neotropical Fauna and Environment* 45: 95-100.

- ROIG-JUÑENT SA & S COSCARÓN (2001) Biogeographical history of the Neotropical and Neantarctic Simuliidae (Diptera). *Revista del Museo Argentino de Ciencias Naturales (Argentina)* 3: 119-134.
- RONQUIST F (1996) DIVA v. 1.1. Computer program for MasOS and Win32. URL: <http://morphbank.ebc.uu.se/DIVA> (accessed December 10, 2008).
- RONQUIST F (1997) Dispersal-vicariance analysis: A new approach to the quantification of historical biogeography. *Systematic Biology* 46: 195-203.
- RONQUIST F (1998) Phylogenetic approaches in coevolution and biogeography. *Zoologica scripta* 26: 313-322.
- RONQUIST F (2002) Parsimony analysis of coevolving species associations. In: RDM Page (ed) *Cospeciation*: 22-64. Chicago University Press, Chicago IL.
- ROZKOSNY R, G FRANTISEK & AC PONT (1997) The European Fanniidae (Diptera). *Acta Scientiarum Naturalium Academiae Scientiarum Bohemicae Brno* 31: 1-80.
- SANMARTÍN I, IH ENGHOF & F RONQUIST (2001) Patterns of animal dispersal, vicariance and diversification in the Holarctic. *Biological Journal of the Linnean Society* 73: 345-390.
- SANMARTÍN I & F RONQUIST (2004) Southern hemisphere biogeography inferred by event-based models: Plant versus animal patterns. *Systematic Biology* 53: 216-243.
- SANMARTÍN I (2007) Event-based Biogeography: Integrating patterns, processes, and time. In: Ebach MC & RS Tangney (eds) *Biogeography in a changing world*: 135-159. The systematics association special volume series 70, CRC press, Boca Raton.
- SIDDAL ME & AG KLUGE (1997) Probabilism and phylogenetic inference. *Cladistics* 13: 313-336.
- SMITH KGV (1986) *A manual of forensic entomology*. London: The Trustees of the British Museum.
- TANGELDER IRM (1988) The biogeography of the Holarctic *Neprotoma-dorsalis* species group (Diptera: Tipulidae). *Neauforti* 31: 1-35.
- WATT JC (1975) The terrestrial insects. In: Kuschel G (ed) *Biogeography and ecology in New Zealand*: 507-533. Dr W. Junk b.v. The Hague, The Netherlands.
- WINKWORTH RC, SJ WAGSTAFF, D GLENNY & PJ LOCKHART (2002) Plant dispersal N.E.W.S. from New Zealand. *Trends in Ecology and Evolution* 17: 514-520.
- WOOD DM (1978) Taxonomy of the Nearctic species of *Twinnia* and *Gymnopais* (Diptera: Simuliidae) and a discussion of the ancestry of Simuliidae. *Canadian Entomologist* 110: 1297-1338.
- YEATES DK & ME IRWIN (1996) Apioiceridae (Insecta: Diptera): Cladistic reappraisal and biogeography. *Zoological Journal of the Linnean Society* 116: 247-301
- ZINSMEISTER WJ (1987) Cretaceous paleogeography of Antarctica. *Paleogeography, Paleoclimatology and Paleocology* 59: 197-206.

*Associate Editor: Marco Méndez*

*Received February 23, 2010; accepted January 14, 2011*



## APPENDIX

Species included in the biogeographical analysis and their geographical distribution according to Chillcott (1961a, 1961b), Pont (1977, 1980), Albuquerque et al. (1981), Holloway (1985), Pont & Carvalho (1994), Carvalho et al. (2003), Rozkosny et al. (1997), Moore & Savage (2006) and Domínguez (2007).

Lista de las especies incluidas en el análisis biogeográfico y su distribución geográfica de acuerdo a Chillcott (1961a, 1961b), Pont (1977, 1980), Albuquerque et al. (1981), Holloway (1985), Pont & Carvalho (1994), Carvalho et al. (2003), Rozkosny et al. (1997), Moore & Savage (2006) y Domínguez (2007).

Genus	Species group	Species	Distribution	Reference in text and figures
<i>Australofannia</i>		<i>A. spiniclunis</i> Pont	Australia	E
<i>Piezura</i>		<i>P. graminicola</i> (Zetterstedt)	Holarctic	ABC
<i>Euryomma</i>		<i>E. peregrinum</i> (Meigen)	Cosmopolitan	ABCDEFGH
<i>Fannia</i>	<i>anthracina</i>	<i>F. albitarsis</i> Stein	Africa, Australia, New Zealand, Neotropical, Patagonia	DEFGH
		<i>F. anthracina</i> (Walker)	Neotropical, Patagonia	GH
		<i>F. bigoti</i> (Stein)	Patagonia	G
		<i>F. confusa</i> Pont & Carvalho	Patagonia	G
		<i>F. pusilla</i> (Bigot)	Patagonia	G
		<i>F. schnusei</i> Stein	Patagonia	G
		<i>F. setosa</i> (Bigot)	Patagonia	G
		<i>benjamini</i>	<i>F. benjamini</i> Malloch	Nearctic
		<i>F. clavata</i> Chillcott	Nearctic	A
	<i>carbonaria</i>	<i>F. carbonaria</i> (Meigen)	Nearctic, western Palaearctic	AB
		<i>F. minutipalpis</i> (Stein)	Western Palaearctic	B
		<i>F. norvegica</i> Ringdahl	Holartic	ABC
		<i>F. polychaeta</i> (Stein)	Western Palaearctic	B
	<i>canicularis</i>	<i>F. aequilineata</i> Ringdahl	Western Palaearctic	B
		<i>F. canicularis</i> (Linnaeus)	Western Palaearctic	B
		<i>F. difficilis</i> (Stein)	Holarctic	ABC
		<i>F. femoralis</i> (Stein)	Nearctic, Neotropical	AH
		<i>F. lucidula</i> (Zetterstedt)	Holarctic	ABC
		<i>F. pusio</i> (Wiedemann)	Nearctic, western Palaearctic, Africa, Neotropical	ABDH
		<i>F. trimaculata</i>	Nearctic, Neotropical	AH
<i>F. petrocchia</i> Shannon & Del Ponte		Neotropical	H	
<i>flavipalpis</i>	<i>F. flavipalpis</i> Stein	Neotropical	H	
	<i>F. grandis</i> Malloch	Neotropical	H	
<i>grandis</i>	<i>F. bahiensis</i> Albuquerque	Neotropical	H	
<i>heydenii</i>	<i>F. bella</i> Albuquerque	Neotropical	H	
	<i>F. heydenii</i> (Wiedemann)	Neotropical	H	
	<i>F. pennicilaris</i> Stein	Neotropical	H	
	<i>F. tucumanensis</i> Albuquerque	Neotropical	H	
	<i>F. tumidifemur</i> Stein	Neotropical	H	
	<i>F. armata</i> (Meigen)	Nearctic, western Palaearctic	AB	
	<i>hirticeps</i>	<i>F. hirticeps</i> (Stein)	Nearctic, western Palaearctic	AB
		<i>F. nidica</i> Collin Western	Palaearctic	B
	<i>F. lepida</i> (Wiedemann)	Holarctic	ABC	
<i>lepida</i>	<i>F. genualis</i> (Stein)	Nearctic, western Palaearctic	AB	

(Cont. Appendix)

Genus	Species group	Species	Distribution	Reference in text and figures
	<i>lugubrina</i>	<i>F. lugubrina</i> (Zetterstedt)	Nearctic, western Palaearctic	AB
		<i>F. metallipenis</i> (Verrall)	Holarctic	ABC
<i>metallipenis</i>		<i>F. hirtifemur</i> (Stein)	Neotropical	H
<i>obcurinervis</i>		<i>F. obcurinervis</i> Stein	Neotropical	H
		<i>F. postica</i> (Stein)	Nearctic, western Palaearctic	AB
<i>postica</i>		<i>F. ringdahlana</i> Collin	Eastern and western Palaearctic	BC
		<i>F. spathiophora</i> Malloch	Holarctic	ABC
		<i>F. umbrosa</i> (Stein)	Western Palaearctic	B
		<i>F. posticata</i> (Meigen)	Palaearctic	BC
<i>posticata</i>		<i>F. fuscula</i> (Fallén)	Holarctic	ABC
<i>scalaris</i>		<i>F. incisurata</i> (Zetterstedt)	Cosmopolitan	ABCDEFGH
		<i>F. lustrator</i> (Harris)	Palaearctic	BC
		<i>F. scalaris</i> (Fabricius)	Cosmopolitan	ABCDEFGH
		<i>F. nigra</i> Malloch	Palaearctic	BC
<i>serena</i>		<i>F. sociella</i> (Zetterstedt)	Holarctic	ABC
		<i>F. serena</i> (Fallén)	Holarctic	ABC
		<i>F. rondanii</i> (Strobl)	Holarctic	AB
		<i>F. mollissima</i>	Holarctic	ABC
		<i>F. anteroventralis</i> Pont	Australia	E
		<i>F. capitalis</i> Pont	Australia	E
		<i>F. coxata</i> Shannon & Del Ponte	Neotropical	H
		<i>F. fasciata</i> Stein	Africa	D
		<i>F. flavicornis</i> Stein	Neotropical	H
		<i>F. fruticosa</i> Stein	Africa	D
		<i>F. fusconotata</i> (Rondani)	Neotropical	H
		<i>F. hermani</i> Domínguez	Neotropical	H
		<i>F. howei</i> Pont	Australia	E
		<i>F. losgateados</i> Domínguez	Neotropical	H
		<i>F. norfolki</i> Pont	Australia	E
		<i>F. perpulchra</i> Bezzi	Africa	D
		<i>F. prolata</i> Chillcott Eastern	Palaearctic	C
		<i>F. punctiventris</i> Malloch	Patagonia	G
		<i>F. roigi</i> Domínguez	Neotropical	H
		<i>F. setigena</i> Villeneuve	Africa	D
		<i>F. suturalis</i> Stein	Africa	D
		<i>F. tasmaniae</i> Pont	Australia	E
		sp 1-6	New Zealand	F