

SPECIES DELIMITATION WITH ABC AND OTHER COALESCENT-BASED METHODS: A TEST OF ACCURACY WITH SIMULATIONS AND AN EMPIRICAL EXAMPLE WITH LIZARDS OF THE *LIOLAEMUS DARWINII* COMPLEX (SQUAMATA: LIOLAEMIDAE)

Arley Camargo,^{1,2} Mariana Morando,³ Luciano J. Avila,³ and Jack W. Sites, Jr.¹

¹Department of Biology & Monte L. Bean Museum, Brigham Young University, Provo, Utah 84602

²E-mail: arley.camargo@gmail.com

³CONICET-CENPAT, Boulevard Almirante Brown 2915, U9120ACD, Puerto Madryn, Chubut, Argentina

Received April 16, 2011

Accepted March 7, 2012

Data Archived: Dryad: doi:10.5061/dryad.4409k652

Species delimitation is a major research focus in evolutionary biology because accurate species boundaries are a prerequisite for the study of speciation. New species delimitation methods (SDMs) can accommodate nonmonophyletic species and gene tree discordance as a result of incomplete lineage sorting via the coalescent model, but do not explicitly accommodate gene flow after divergence. Approximate Bayesian computation (ABC) can incorporate gene flow and estimate other relevant parameters of the speciation process while testing alternative species delimitation hypotheses. We evaluated the accuracy of BPP, SpeDeSTEM, and ABC for delimiting species using simulated data and applied these methods to empirical data from lizards of the *Liolaemus darwinii* complex. Overall, BPP was the most accurate, ABC showed an intermediate accuracy, and SpeDeSTEM was the least accurate under most simulated conditions. All three SDMs showed lower accuracy when speciation occurred despite gene flow, as found in previous studies, but ABC was the method with the smallest decrease in accuracy. All three SDMs consistently supported the distinctness of southern and northern lineages within *L. darwinii*. These SDMs based on genetic data should be complemented with novel SDMs based on morphological and ecological data to achieve truly integrative and statistically robust approaches to species discovery.

KEY WORDS: Divergence, gene flow, gene trees, simulation, speciation.

The practice of species delimitation is a major research focus in evolutionary biology because the accurate assessment of species boundaries is a prerequisite for the study of speciation. Progress has been made in the species concept (de Queiroz 2011; Hausdorf 2011) but the issue of delimiting species in practice has received little attention (Wiens 2007). However, species delimitation

has been a growing topic in the literature (see results of database searches in Appendix S1) and criteria continue to be introduced (reviewed in Marshall et al. 2006). These include inference keys with assessments of gene flow (Wiens and Penkrot 2002), measures of lineage exclusivity (Cummings et al. 2008), a statistical fit of the threshold between inter- and intraspecific

divergence (Pons et al. 2006), and more recently, optimization approaches for minimizing gene tree discordance across species limits (O'Meara 2010). The practice of species delimitation with molecular data is expanding rapidly due in part to the development of the multispecies coalescent (Rannala and Yang 2003; Degnan and Rosenberg 2009), and the application of this framework for inference of species relationships (Edwards 2009).

Most coalescent-based species delimitation methods (SDMs) can accommodate incomplete lineage sorting (ILS) via the coalescent model (Knowles and Carstens 2007). In this context, large ancestral population sizes and shallow divergence times are expected to increase levels of ILS (Funk and Omland 2003). One approach consists of hypothesizing a species tree and associated species boundaries, and then calculating the probability of all gene trees under that species history. Subsequently, likelihoods are calculated for nested species histories (as when two species are collapsed into one) and a likelihood ratio statistic is used to test the null hypothesis of no-speciation (Knowles and Carstens 2007). However, when models of species limits are nonnested, a more appropriate approach uses Akaike information criteria (AIC) to test alternatives (Carstens and Dewey 2010). This method is implemented in the java pipeline SpeDeSTEM 0.1.1 (Ence and Carstens 2011), based on the program STEM 1.0, assuming that gene trees are known without error (point estimates) and that population sizes have remained constant along the species tree (Kubatko et al. 2009). In this approach, a molecular clock is enforced on estimated gene trees, the mutation rate parameter (θ) is estimated from the data, and species trees are reestimated for each species delimitation hypothesis.

An alternative Bayesian approach consists of sampling from the posterior distribution of models of species limits using reversible-jump Markov chain Monte Carlo (rjMCMC) as implemented in the program BPP 2.1 (Yang and Rannala 2010). This approach uses a fixed, fully resolved guide tree of species lineages, which is used to derive alternative models of species limits by sequentially collapsing internal nodes. Priors should be given for population sizes and divergence times of the species tree in addition to the priors and proposal mechanisms of the regular MCMC chains for estimating gene trees. Therefore, in this approach, the uncertainty in the gene trees is explicitly incorporated in the models, θ is estimated and allowed to vary along the species tree, but a fixed species tree topology should be provided a priori.

Coalescent methods used in current species delimitation approaches do not explicitly accommodate for gene flow after divergence (Yang and Rannala 2010; Ence and Carstens 2011). However, because speciation with limited gene flow appears to be common in nature (Nosil 2008; Pinho and Hey 2010), species delimitation should also take into account the process of divergence with gene flow (Hey 2009, 2010). Most often, disruptive selection is the main cause of divergence in spite of gene flow

(Pinho and Hey 2010), but intraspecific gene flow might also play a role (Zhou et al. 2010). If two species have diverged with occasional gene flow, SDMs accommodating only ILS are expected to collapse these species into a single lineage due to the homogenizing effect of gene flow. Alternatively, if species are not collapsed, gene flow could instead lead to underestimates of divergence times between species (Nielsen and Wakeley 2001). However, it is possible that even if gene flow is not accounted for, some SDMs may still be robust to the impact of gene flow and correctly separate species (Ence and Carstens 2011).

One way of incorporating gene flow into species delimitation is via approximate Bayesian computation (ABC) methods. The use of ABC techniques started in the field of population genetics in 1997, but they have become very popular in phylogeography, ecology, epidemiology, and phylogenetics (Beaumont 2010; Bertorelle et al. 2010; Csilléry et al. 2010a; Fan and Kubatko 2011), and the literature shows an important increase in the number of published studies that have used ABC in recent years (Appendix S1). ABC represents a group of likelihood-free algorithms that in their most basic formulation consist of (1) sampling parameter values from prior distributions to generate simulated data; (2) calculating summary statistics (SuSt) from simulated and observed data and the Euclidean distance between them; and (3) approximating the posterior distribution of parameters with a rejection algorithm that retains those simulations that have an Euclidean distance smaller than a prespecified threshold or tolerance (Lopes and Beaumont 2010). This procedure represents the original ABC formulation known as rejection-ABC, but step (3) has been modified to include a weighted local linear regression to correct the discrepancy between observed and simulated SuSt for increasing accuracy (regression-ABC) (Beaumont et al. 2002).

In addition to parameters, different demographic models can be compared to select models based on posterior probabilities and/or Bayes factors. For example, in the context of rejection-ABC, the frequency of retained simulations generated under one model relative to all retained simulations represents its posterior probability, given that all models have the same prior number of simulations (Pritchard et al. 1999). An improved and more accurate estimator of model probabilities includes an adjustment using weighted multinomial logistic regression (Beaumont 2008). Recently, a machine learning approach based on nonlinear neural networks regression has been introduced for parameter estimation and model choice that relaxes assumptions and outperforms linear regression-ABC (Blum and François 2010). A complete ABC analysis requires not only simulating and estimating parameters of models, but also validating and testing the accuracy of the selected model using predictive tests (Bertorelle et al. 2010; Csilléry et al. 2010a). Despite some recent criticisms about incoherent and illogical model inference (Templeton 2009, 2010a,b), several authors have defended the validity of model comparison

with ABC within a Bayesian framework (Beaumont et al. 2010; Berger et al. 2010; Csilléry et al. 2010b). In addition, the pitfalls of ABC in terms of model and prior misspecification, number and kind of SuSt, and number of simulations, can be addressed with quality controls based on pseudo-observed data and exploratory simulations (Bertorelle et al. 2010).

We applied SDMs to lizards of the *Liolaemus darwini* complex (Squamata, Liolaemidae) that occupy sandy habitats in the southern and central portions of the Monte Desert in Argentina (Etheridge 1993). The complex includes *L. darwini*, *L. grosseorum*, and *L. laurenti*, which form a clade within the more inclusive *L. darwini* group (Camargo et al. 2012). Detailed morphological studies revealed that *L. laurenti* (Catamarca, La Rioja, and San Juan Provinces), and *L. grosseorum* from (Mendoza, Neuquén, La Pampa, and Río Negro Provinces), were distinct species from *L. darwini* based on diagnostic meristic characters (scale and preloacal pores), male color patterns, and tail and body proportions (Etheridge 1992, 2001). The remaining geographic distribution of *L. darwini* has been partitioned into northern (*L. darwini*-N) and southern (*L. darwini*-S) populations based on an apparent distributional gap in central Mendoza Province (see Fig. 1), scale count/color variation, and genetic differentiation (Etheridge 2001; Morando et al. 2004; Abdala 2007). A mtDNA study recovered a single southern (= *L. darwini*-S) and several northern (N1 and N2 = *L. darwini*-N) clades, which were interpreted as candidate species (Morando et al. 2004). In addition, based on paraphyletic patterns in the mtDNA gene tree, geographic distributions, and coalescent expectations, ILS and/or introgression was inferred to occur between *L. darwini*-N versus *L. laurenti*, and between *L. darwini*-S and *L. grosseorum* (Morando et al. 2004). Subsequently, Abdala (2007) assigned *L. darwini*-N and two lineages of *L. darwini*-S to different terminals in his phylogenetic analyses, and concluded that they probably represent different species pending more detailed analyses. These studies also found that a morphologically distinct and probably parthenogenetic form appears nested among *L. darwini*-S and *L. darwini*-N (Morando et al. 2004; Abdala 2007).

Species trees based on multilocus datasets recovered a sister relationship between *L. laurenti* and *L. grosseorum* (Camargo et al. 2012). Based on these relationships, two different diversification patterns appear to have occurred in this complex: (1) a morphologically divergent species pair (*L. laurenti* vs. *L. grosseorum*) with fully allopatric distributions; and (2) a morphologically more conserved pair of lineages (*L. darwini*-N vs. *L. darwini*-S) with nearly parapatric distributions. Herein, we (1) introduce an ABC approach for delimiting species, (2) compare the accuracy of ABC and other coalescent-based SDMs using simulations, and (3) apply these methods to empirical data of the *L. darwini* complex, after excluding the parthenogen form because its possible hybrid parentage (M. Morando, unpubl. data)

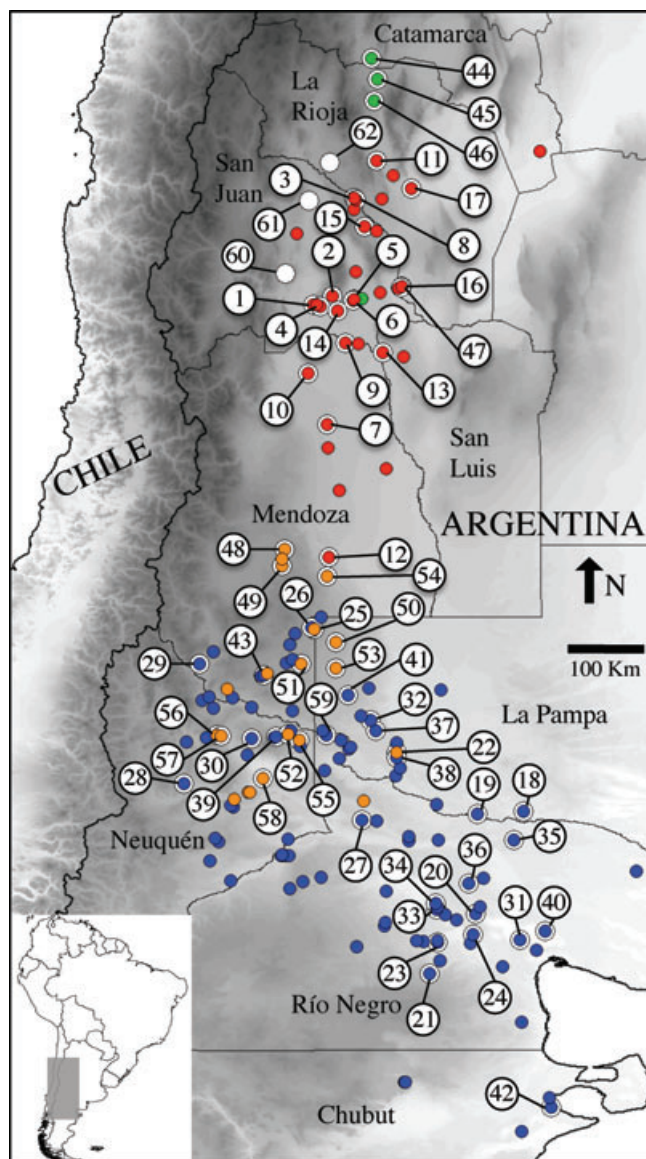

Figure 1. Map of central Argentina showing localities for species of the *Liolaemus darwini* complex. Blue dots, *L. darwini*-S; red dots, *L. darwini*-N; green dots, *L. laurenti*; orange dots, *L. grosseorum*; open dots, *L. olongasta* (used in species tree only). Numbers in open circles represent the localities sampled in this study, which are listed in Appendix S2.

cannot be handled by the SDMs used in this study (all assume strictly bifurcating species trees).

Methods

SIMULATION TESTING

We simulated sequence data for the same speciation model used by Ence and Carstens (2011), which consisted of four lineages (A, B, C, and D) (Fig. 2A). We simulated 100 coalescent replicates with the program *ms* (Hudson 2002) for a total of 61 gene copies

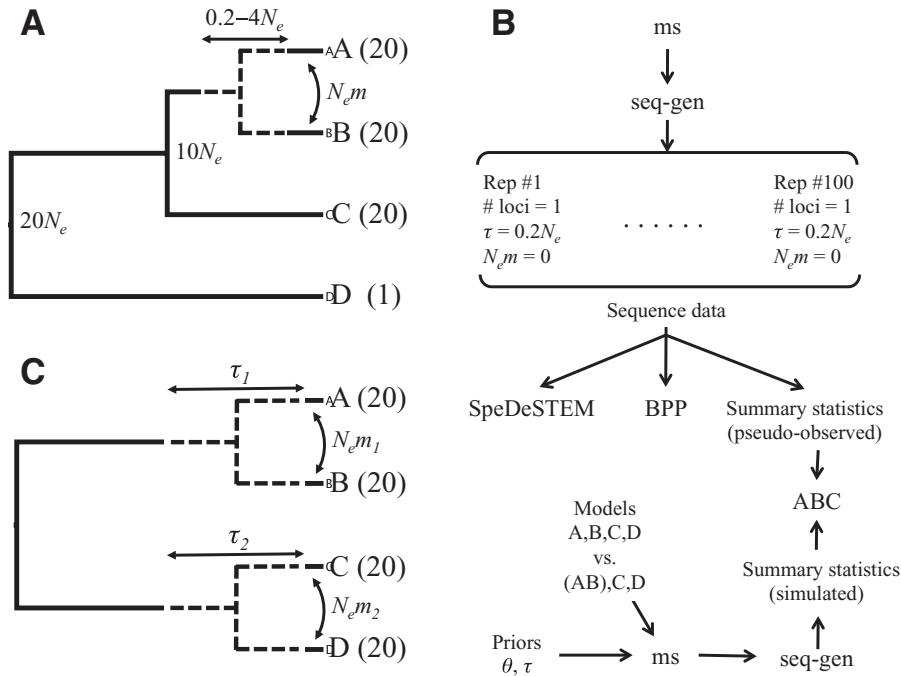

Figure 2. Speciation models and simulation design for testing accuracy and analyzing empirical data with approximate Bayesian computation (ABC). The speciation model (A) was used to generate pseudo-observed treatments that were subsequently analyzed with SpeDeSTEM, BPP, and ABC (B). The speciation model (C) was used to test for speciation and estimate demographic parameters in the *Liolaemus darwini* complex. Numbers in parentheses represent sample sizes used in simulations.

(20 for A, B, and C, and one for D) and a variable number of loci (1, 2, 4, and 10 loci) (Fig. 2B). A constant population size was used for all lineages ($\theta = 4N_e\mu = 7$) derived from the mean empirical value among lineages in the observed data. The divergence time (τ) between lineages A and B varied between $0.2N_e$ and $4N_e$ generations and the migration rate between these lineages (m , the proportion of gene copies replaced by immigrant gene copies each generation) was set to either $N_e m = 0$ (no migration) or $N_e m = 0.5$ (moderate migration). Each combination of number of loci, divergence time, migration rate was considered as a separate treatment for analysis. Subsequently, we generated sequence data for these coalescent genealogies using seq-gen (Rambaut and Grassly 1997) and the same settings of Ence and Carstens (2011), for a total of 500 base pairs (bp) and approximately 50 variable sites per locus, similar to the observed values in our empirical data (see Results). Sequence data for each locus in nexus format was transformed to the phylip format for analysis with BPP using the “seqConverter.pl v1.2” Perl script written by O. Bininda-Emonds (available at <http://www.molekularesystematik.uni-oldenburg.de/33997.html>). Nexus files were also transformed to the input format of popABC (Lopes et al. 2009) with the “nexus2table” script available from the following website: <http://code.google.com/p/popabc/>.

The nexus files were used as input for analysis with SpeDeSTEM using θ per site = 0.014, which equals θ per lo-

cus = 7. We ran 10 replicated analyses for each simulated dataset using the same settings for the substitution models as those used in seq-gen and subsampling five sequences per lineage in each replicate. Based on AIC values, we calculated accuracy as the mean model probabilities (ω_i , the probability that model i is the best model of the set) values across the 100 simulations of each treatment for the model that considered the lineages A and B as separate species.

The input files in phylip format were analyzed in BPP with algorithm 0 and the fine-tune parameter $\epsilon = 15$. The θ prior followed a gamma distribution with parameters $\alpha = 2$ and $\beta = 143$, which results in a mean $\theta = 0.014$. The τ prior for the root was also a gamma distribution with $\alpha = 2$ and $\beta = 57$ to produce a mean $\tau = 0.035$ ($\sim 20N_e$). The step lengths for proposals in the MCMC were automatically adjusted to obtain optimal acceptance rates during the analysis that consisted of a burn-in phase of 50,000 steps and 100,000 posterior samples sampled every five steps. We measured accuracy as the mean speciation probability (the sum of the models supporting speciation between A and B; following Leaché and Fujita 2010) across the 100 replicates of each treatment.

The input files in popABC format (.len) were processed with the “summdata” program of popABC to generate 12 global SuSt (Table S1) to be used as pseudo-observed data (pods) in ABC analyses. We excluded the population-specific SuSt because they

cannot be compared between models with different numbers of populations. We generated simulated SuSt for the speciation model above (Fig. 2A) with the same fixed θ and $N_e m$, but with uniform priors for τ ranging between 0.04 and $6N_e$. In addition, we also simulated a model of no-speciation where A and B were collapsed into a single lineage (Fig. 2B). One million simulations for each model were concatenated into a single prior file including a binary index parameter that identified the model under which the simulations were generated (e.g., 0 = speciation, 1 = no-speciation) and the same 12 SuSt.

To evaluate the accuracy of ABC to distinguish between speciation versus no-speciation models, we input the prior file into the R package “abc” version 1.4 (Csilléry et al. 2012, <http://cran.r-project.org/web/packages/abc/index.html>) to run the model selection function “postpr.” This procedure was repeated for each of the 100 pods simulated for each treatment to evaluate accuracy in selecting the speciation model with the neural-network ABC algorithm, which has been shown to outperform other algorithms (Blum and François 2010). Tolerance was set to 0.0001 to retain 200 accepted simulations for estimating posterior distributions. We calculated the mean posterior probability of the speciation model across 100 pods to measure the accuracy under each treatment. Even though posterior probabilities and model probabilities are not comparable directly, we applied the criterion that a method successfully delimited species when their accuracies were >95% across the 100 pods.

All simulations were run in the marylou5 supercomputer cluster in the Fulton Supercomputing Lab at BYU (<https://marylou.byu.edu/>). Perl scripts written for generating sequence data and SuSt under different treatments are deposited in Dryad (doi:10.5061/dryad.4409k652).

Empirical Data

We sampled 398 individuals of *L. darwini* from 134 localities including the distribution of southern and northern lineages, 69 individuals of *L. grosseorum* from 20 localities, and 38 individuals of *L. laurenti* from eight localities (Fig. 1, Appendix S2). Tissue samples from liver and/or tail muscle were preserved in absolute ethanol and stored at -20°C . Specimens were fixed in 10–20% formalin, later transferred to 70% ethanol, and deposited in the herpetological collection of the Centro Nacional Patagónico (LJAMM-CNP, CENPAT-CONICET; <http://www.cenpat.edu.ar/nuevo/colecciones03.html>) and the Bean Life Science Museum, Brigham Young University (<http://mlbean.byu.edu/ResearchCollections/Collections/ReptilesandAmphibians.aspx>).

Genomic DNA was extracted with the DNAeasy Qiagen kit (Qiagen, Valencia, CA). We used the Green Go Taq PCR kit (Promega, Madison, WI) for all PCR reactions in PTC-200 DNA Engine (MJ Research, Waltham, MA) or GeneAmp PCR

9700 thermal cyclers (Applied Biosystems, Inc., Carlsbad, CA). Sequencing reactions used the Big-Dye Terminator version 3.1 Cycle Sequencing Kit (Applied Biosystems, Inc.) in a GeneAmp PCR 9700 thermal cycler (Applied Biosystems, Inc.). Sequencing products were cleaned with Sephadex G-50 Fine (GE Healthcare Bio-Sciences AB, Piscataway, NJ) and sequenced in an ABI 3730xl DNA Analyzer (Applied Biosystems, Inc.). We sequenced the cytochrome *b* (*cyt b*) mtDNA gene for all available individuals of *L. darwini* (including north and south lineages), *L. grosseorum*, and *L. laurenti* (~500 individuals) following protocols in Morando et al. (2004). We subsampled 10 individuals across the geographic distribution of each lineage representing the variation found in mtDNA haplotypes for screening three anonymous nuclear loci (ANL) (Appendix S2). We sequenced three ANL (A1D, A9C, and B6B) that were developed from the genomic DNA of an *L. darwini* individual (LJAMM-CNP 7097) following protocols in Noonan & Yoder (2009). We generated approximately 200 random fragments, cloned, sequenced, and BLAST searched these to confirm they were anonymous, then designed primers for fragments with confirmed anonymity and used the PCR temperature profile of Noonan & Yoder (2009) to amplify ANL in all sampled individuals.

Chromatograms were checked by eye and ambiguity codes were used to represent polymorphisms of heterozygous individuals in Sequencher 4.7 (Gene Codes Corporation, Ann Arbor, MI). Gametic phase of heterozygotes was resolved with the program Phase 2.1.1 (Stephens et al. 2001). Sequences were aligned with ClustalX 2.0.10 (Larkin et al. 2007) and inspected by eye to check that there were no fixed heterozygotes at any polymorphic site to insure we were not using multiple-copy markers (Thomson et al. 2010). Alignments were tested for recombination with the program RDP3 beta35 (Martin et al. 2005). We estimated a gene tree for each locus using BEAST 1.6.1 (Drummond and Rambaut 2007) based on a coalescent tree prior, 10 million generations sampled every 1000 states, and a burn-in of 1000 trees. After selecting an appropriate burn-in period with Tracer version 1.5 (Rambaut and Drummond 2007), the collection of posterior trees was summarized as the consensus tree with the maximum clade credibilities in TreeAnnotator (Drummond and Rambaut 2007). For estimation of a species tree, we selected three individuals to represent each lineage from localities distant from haplotype boundaries or contact zones to minimize the potential impact of intermixed/migrant individuals (Leaché 2009). We included also *L. olongasta*, a closely related species to the focal clade in this study, and *L. boulengeri*, an outgroup of the *L. darwini* group.

EMPIRICAL SPECIES DELIMITATION

We first evaluated alternative demographic scenarios for the *L. darwini* complex assuming that they actually consisted of four

separate lineages using the program IMA2 (Hey 2010). Following recommendations of the program's manual, we ran 20 Metropolis-coupled Monte Carlo Markov chains (MC³) with geometric heating ($h1 = 0.96$, $h2 = 0.90$). We also followed the author's suggestions and after preliminary runs, we set the upper bounds for θ (100), τ (25), and M (10), and sampled 100,000 states after discarding 250,000 initial states. We provided the species tree estimated with *BEAST (see below) to be used as the guide tree and specified a full model with migration between sampled populations only (option -j3). Subsequently, we used log-likelihood values to rank the full and the nested demographic models based on information-theoretic criteria (Carstens et al. 2009). We evaluated a total of 20 nested models of the full migration model (all migration rates estimated as different parameters), where migration rates were either set to be equal between sister species or set to zero. The divergence time parameter estimated in mutation units was multiplied by $2/\theta$ to transform to coalescent units (Liu et al. 2010).

We delimited species in the *L. darwinii* complex with ABC via simulating a new speciation model consisting of a symmetric four-species tree (with symmetric migration between sister species) and a no-speciation model of two species that results from collapsing each sister species pair of the speciation model (Fig. 2C). We simulated four loci for both models and 20 gene copies per lineage. Uniform priors for θ ranged between 0.1 and 30, prior τ between 0.04 and $8N_e$, and prior $N_e m$ between 0.01 and 0.5. Using the same procedure as in the simulation testing section, we calculated 12 global SuSt for the simulated sequence data and for the empirical data. Again, simulated and observed SuSt were input into R to perform ABC analysis with the *postpr* command for estimating the posterior probability of the speciation model with four species. Moreover, to obtain parameter estimates for comparison with the results from IMA2, we generated a new prior with 44 (global and population-specific) SuSt for the four-species model and for the observed data (Table S2). Simulated and observed SuSt were analyzed with the *abc* command of the R-package "abc" (Csilléry et al. 2012), using logistic transformation to insure that parameter estimates were within the prior bounds used in simulations. In addition, we used 100 pods to assess bias in parameter estimates as the difference between the real parameter value and the mean estimated value. We also calculated the relative bias with respect to the range of the prior distributions, and parameter coverage, which is the percentage of simulations where the true value falls within the 95% highest posterior density (HPD). We assessed how well the simulated models fit the observed data via a principal components analysis (PCA) of simulated SuSt and observed SuSt. A good fit in this prior predictive plot was interpreted when the observed SuSt occurred within the cloud of simulated SuSt. Perl scripts written to gen-

erate simulated SuSt for species delimitation and for parameter estimation with ABC are deposited in Dryad (doi:10.5061/dryad.4409k652).

We analyzed the empirical dataset with SpeDeSTEM 0.9.4 (Ence and Carstens 2011) and BPP 2.1 (Yang and Rannala 2010) for comparison with the ABC results. SpeDeSTEM is a java-based pipeline that uses gene trees obtained with PAUP* to estimate maximum-likelihood species trees with the program STEM (Kubatko et al. 2009) for alternative models of species limits that are evaluated with AIC (Ence and Carstens 2011). Best-fit substitution models for the species delimitation dataset were estimated with jModelTest 0.1.1 from the pool of 88 competing models using the Bayesian information criterion (Posada 2008). Relative mutation rates of loci and average θ across lineages were calculated with Migrate-n 3.2.1 (Beerli and Palczewski 2010), using two independent maximum-likelihood runs each consisting of 10 short chains and five long chains sampled every 50 steps, for a total of 2000 and 30,000 generations, respectively, and a burn-in period of 20,000 steps. The relative mutation rate of *cyt b* was divided by 2 to account for the haploid status of this locus (Kubatko et al. 2009). In SpeDeSTEM, we randomly subsampled five sequences from each lineage in 50 replicates following the manual's recommendations (Ence and Carstens 2011) and tested species limits for the sister-lineage pairs *L. darwinii*-N versus *L. darwinii*-S and *L. laurenti* versus *L. gosseorum*.

We estimated a species tree with BEAST version 1.6.1 (Drummond and Rambaut 2007; *BEAST, Heled and Drummond 2010) to be used as a guide tree in BPP analyses. We ran two independent MCMC analyses for 50 million generations with samples taken every 4000 generations, and with the same prior distributions and model settings used in a recent study of the complete *L. darwinii* group (Camargo et al. 2012). Log files were inspected in Tracer version 1.5 (Rambaut and Drummond 2007) to determine an appropriate burn-in sample to estimate the posterior distribution of species trees. In BPP, we analyzed 20 sequences per lineage and per locus (except *L. laurenti*, 16 sequences for *cyt b*) using both algorithms 0 ($\epsilon = 5$ and 10) and 1 ($\alpha = 2$, $m = 1$ and $\alpha = 1$, $m = 2$) to specify the rjMCMC moves between alternative models of species delimitation. In both cases, we varied the parameters α and β of the gamma-distributed priors for θ and τ to take into account a range of speciation histories: large population size/deep divergence (both priors with $\alpha = 2$ and $\beta = 2000$), small population size/shallow divergence (both priors with $\alpha = 1$ and $\beta = 10$), and large population size/shallow divergence ($\alpha = 2$ and $\beta = 2000$ for θ prior; $\alpha = 1$ and $\beta = 10$ for τ prior) (Leaché and Fujita 2010). We used the same relative rates per locus as specified in the SpeDeSTEM analyses. All runs consisted of 50,000 samples taken every five steps with a burn-in period of 10,000 steps.

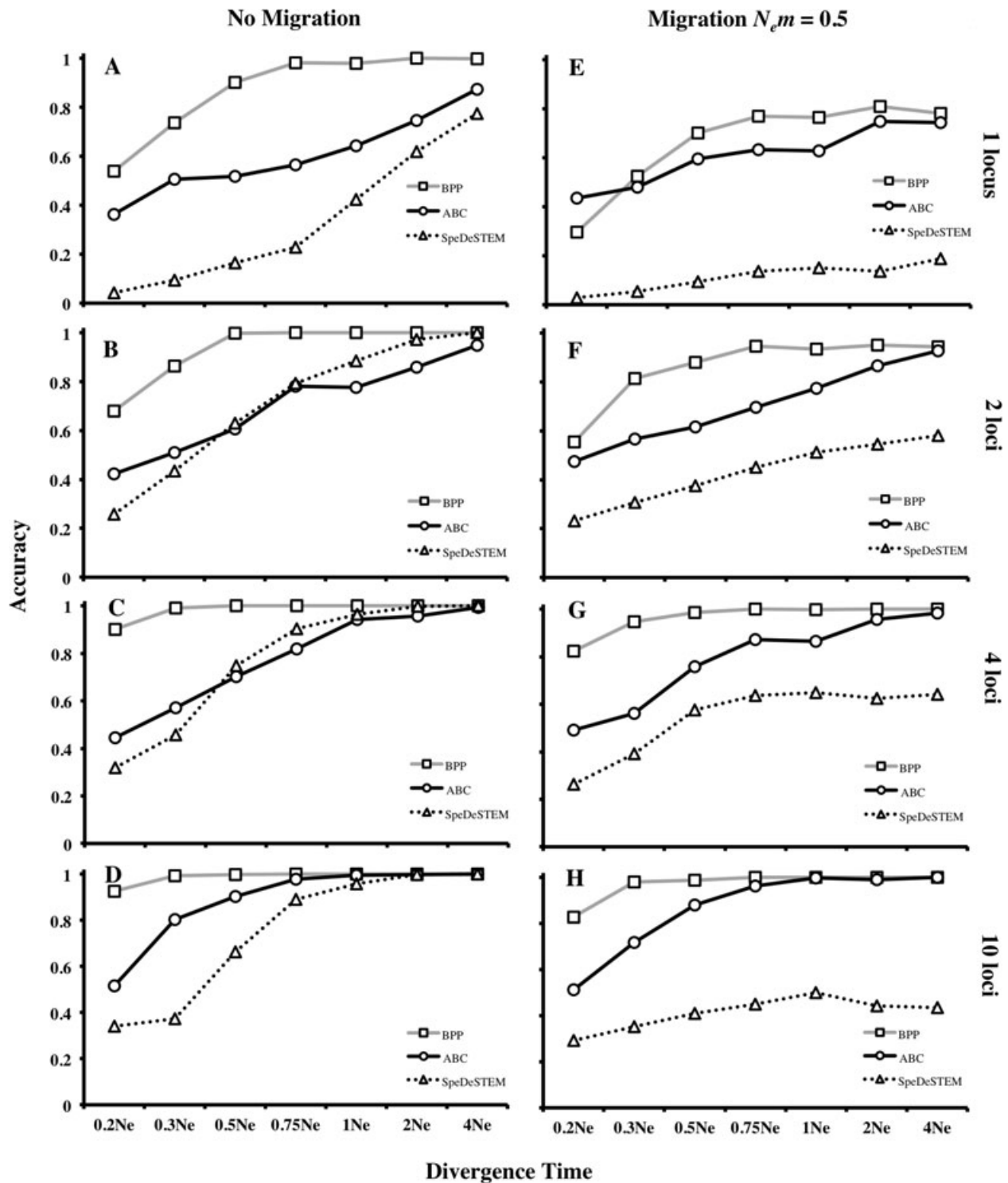

Figure 3. Accuracy of the BPP, SpeDeSTEM, and approximate Bayesian computation (ABC) methods for species delimitation under varying numbers of loci (1–10 loci), divergence times (0.2– $4N_e$), and migration ($N_e m = 0$ –0.5). Accuracy represents the mean posterior probability (for BPP and ABC) or the mean model probability (for SpeDeSTEM) of the correct speciation model (see Fig. 2A).

Results

SIMULATION TESTING

Overall, BPP had the highest accuracy and SpeDeSTEM had the lowest while ABC was intermediate under most conditions

(Fig. 3). In the absence of migration, the limit of accuracy for BPP was at very shallow divergences ($0.3N_e$) using four loci (Fig. 3C), whereas ABC needed 10 loci to distinguish species that diverged at $0.75N_e$ (Fig. 3D), and SpeDeSTEM detected species divergence

at $1N_e$ with either four or 10 loci (Fig. 3C, D). Moreover, BPP was able to delimit species successfully with only one locus at $0.75N_e$ whereas ABC and SpeDeSTEM failed to detect speciation even at $4N_e$ (Fig. 3A). When gene flow occurred during the speciation process, both BPP and ABC were fairly robust showing only slight decreases in accuracy, but SpeDeSTEM was heavily impacted because it was unable to delimit species under all simulated conditions (Fig. 3E–H). In addition, none of the methods was able to delimit species under any conditions with a single locus if there was speciation despite gene flow (Fig. 3E). In relative terms, the accuracy of ABC was basically unaffected when gene flow was included in the simulations (an average decrease across all conditions of 0.05%), while BPP showed a drop of 8%, and SpeDeSTEM decreased in accuracy by almost 27%.

EMPIRICAL SPECIES DELIMITATION

We sequenced 713 bp for *cyt b*, 692 bp for A1D, 481 bp for A9C, and 415 bp for B6B. Twenty sequences were sampled per lineage and per locus, but 16 *cyt b* sequences were obtained for *L. laurenti*, and 12 A1D and 14 B6B sequences were included for *L. darwinii*-S. The program Phase resolved the gametic phase of 73% (82 out of 113) heterozygous base calls from A1D, 93% (140 out of 150) from A9C, and 72% (58 out of 81) from B6B, at the 0.95 confidence level. The most likely, reconstructed haplotype pairs were used in subsequent analyses for those sequences with uncertain phases. No gaps were found in the multiple sequence alignments in any locus. We did not find any fixed heterozygotes at any polymorphic site, suggesting that ANL were single-copy markers (Thomson et al. 2010), and we did not find evidence of recombination in any of the loci analyzed in this study. The most variable locus was *cyt b* with 19% of polymorphic sites (136 out of 713 bp) and in decreasing order of variation: A9C (6.9%, 33 out of 481 bp), A1D (6.6%, 46 out of 700 bp), and B6B (3.1%, 13 out of 415 bp). Gene trees show considerable discordance among them and are not monophyletic within any of the four putative species lineages (Fig. 4). Sequence data are deposited in GenBank with the accession numbers given in Appendix S2.

The simplest demographic model selected in IMA2, with a model probability of $\omega_i = 0.21$, was the one with no migration between *L. darwinii*-N and *L. darwinii*-S, and with migration from *L. laurenti* to *L. grosseorum* (Table S3). The estimated number of migrants per generation from *L. laurenti* to *L. grosseorum* was $N_e m \sim 0.05$, based on $M_{3>2} = 0.0587$ and $\theta_3 = 3.4$ ($4N_e m = M\theta$, see IMA2 manual). The estimated divergence times between *L. darwinii*-N and *L. darwinii*-S were $\tau = 0.45$ substitutions/locus ($=0.4N_e$) and $\tau = 0.83$ for the *L. laurenti*-*L. grosseorum* pair ($=1.1N_e$) (Table 1).

The ABC model selection for the pair *L. darwinii* complex resulted in higher support for the speciation model with a posterior probability of 0.996 compared to the no-speciation model. The

first three PC axes extracted approximately 65% of the total variance out of the 12 SuSt used for species delimitation with good discrimination between the four-species versus two-species models when comparing PC 1 versus 2 and PC 1 versus 3 (Fig. 5A, B). However, the observed SuSt was an outlier suggesting poor model fitting (Fig. 5A–C). Error in parameter estimates ranged between 14% and 18% for θ and τ parameters, but reached 27% for the migration parameter (Table 1). Only 40% of the variance in the 44 SuSt used for parameter estimation was extracted with the first three PC axes and the observed SuSt also appears as an outlier (Fig. 5D–F). The computation time of the prior file containing 2 million simulations of 12 SuSt for species delimitation (1 million from each model) was reduced by running 20 independent jobs in the marylou5 cluster (100,000 simulations per job), each of which took approximately 2.8 h. If using a MacBook Pro laptop with a 2.4 GHz Intel Core 2 Duo processor and 4 GB of memory (2×2 GB 1067 MHz DDR3), the generation of the same prior file would have taken approximately 138 h, based on the computation time of 100 simulations. Model choice and parameter estimates with the ABC procedure in R took less than 1 min in a MacBook Pro laptop.

The relative mutation rates for loci were: 1.75 (*cyt b*), 0.83 (A1D), 1.00 (A9C), and 0.42 (B6B). Mean θ per site across the four lineages analyzed was 0.0072. Based on the substitution models for each locus, relative mutation rates, and mean θ per site, SpeDeSTEM analyses selected the model with all four lineages as separate species with strong AIC support (Table 2). This model had a model probability of $\omega_i \sim 0.99$, indicating that it has a 99% chance of being the best model among the four alternatives analyzed. The model collapsing *L. darwinii*-N and *L. darwinii*-S had very low support, whereas other models had nonsignificant model likelihoods (Table 2). The computation time with SpeDeSTEM in a MacBook Pro laptop was approximately 25 min.

Two independent runs in *Beast recovered an identical species tree with *L. darwinii*-N and *L. darwinii*-S as a strongly supported clade, the pair *L. laurenti* and *L. grosseorum* as a clade with moderate support, and these two species pairs recovered as sister clades with strong support (Fig. S1). Based on this guide tree and the estimated relative mutation rates, BPP consistently found very high speciation probabilities (1.0) for all internal nodes across multiple analyses with different algorithms and prior distributions. Each separate analysis with BPP using different prior settings took approximately 6.5 h in a MacBook Pro laptop.

Discussion

SPECIES DELIMITATION WITH ABC AND OTHER METHODS

ABC is a powerful and flexible approach for model choice and parameter estimation including, for example, the number of

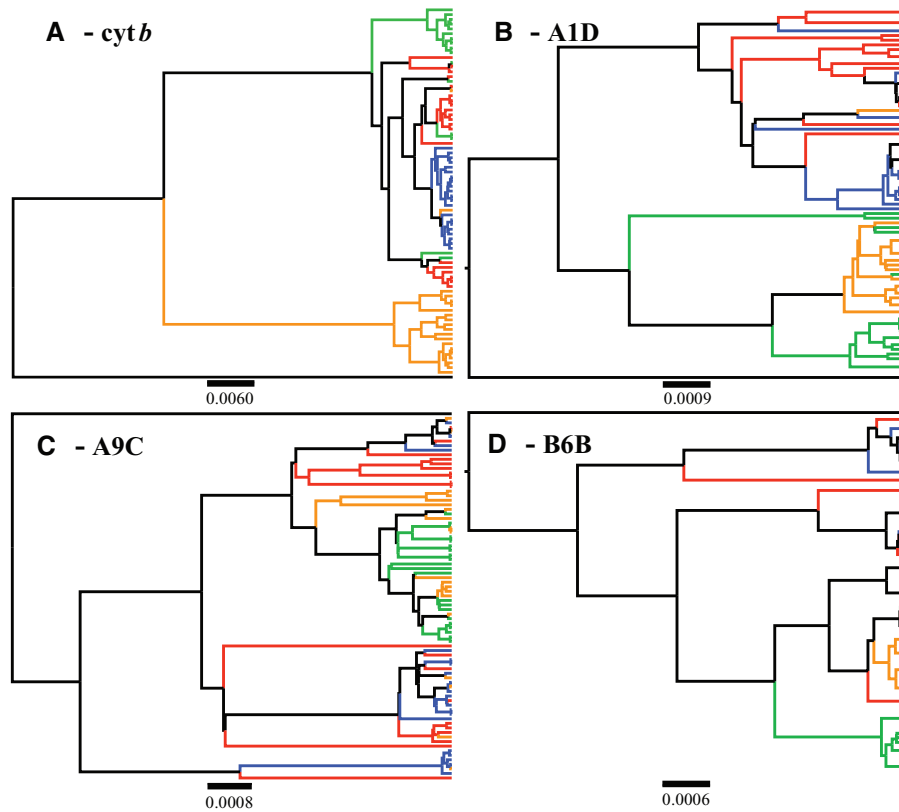

Figure 4. Gene trees of loci sampled for species delimitation analyses. (A) *cyt b*, (B) A1D, (C) A9C, and (D) B6B. Each species lineage is color-coded: *L. darwinii*-N (red), *L. darwinii*-S (blue), *L. laurenti* (green), and *L. grosseorum* (orange). Scale bars represent substitutions per site.

Table 1. Demographic parameter estimates of the *Liolaemus darwinii* complex using IMA2 (based on best model, see Table S3) and approximate Bayesian computation analyses. Subscripts of θ parameters identify populations used in the analysis: 0 = *L. darwinii*-N, 1 = *L. darwinii*-S, 2 = *L. laurenti*, and 3 = *L. grosseorum*. Subscripts of τ (divergence time) parameters represent the two diverging populations. τ_a is the divergence time of the *L. darwinii* complex. $N_e m$ refers to the migration rate parameter (estimated number of migrants per generation) from *L. laurenti* to *L. grosseorum*.

Method	θ_0	θ_1	θ_2	θ_3	τ_{01}	τ_{23}	τ_a	$N_e m$
IMa2	6.80	2.33	2.63	3.41	$0.40N_e$	$1.10N_e$	$3.09N_e$	0.05
ABC	11.9	9.0	13.2	11.2	$0.98N_e$	$3.08N_e$	$5.14N_e$	0.27
Absolute bias	5.14	5.00	4.95	5.40	0.14	0.15	0.32	0.54
Relative bias	17%	17%	17%	18%	14%	15%	8%	27%

populations (Bertorelle et al. 2010). Based on the capabilities of new computer programs for simulation with novel summary statistics (i.e., popABC), and more sophisticated algorithms for model choice (i.e., nonlinear regression-ABC), we applied this approach to species delimitation. We found that BPP outperformed ABC and SpeDeSTEM in most cases but, as we expected, the accuracy of the ABC method in detecting speciation did not decrease when there was gene flow, while BPP, and particularly SpeDeSTEM, showed important decreases in accuracy. In addition, ABC successfully detected two speciation events in the *L. darwinii* complex, despite biased estimates of demographic pa-

rameters. These findings of accurate model choice but estimation error in model parameters are consistent with a recent ABC-based study that was able to distinguish statistically between alternative demographic models in spite of imprecise parameter estimates (Peter et al. 2010).

Our study is the first to apply and evaluate the accuracy of an ABC approach for species delimitation but previous studies have also assessed the accuracy of SpeDeSTEM and BPP. Previous simulations with SpeDeSTEM show that two species that have diverged as recently as $0.5N_e$ generations ago can be distinguished as separate lineages when $\theta = 10$, and five loci and five sequences

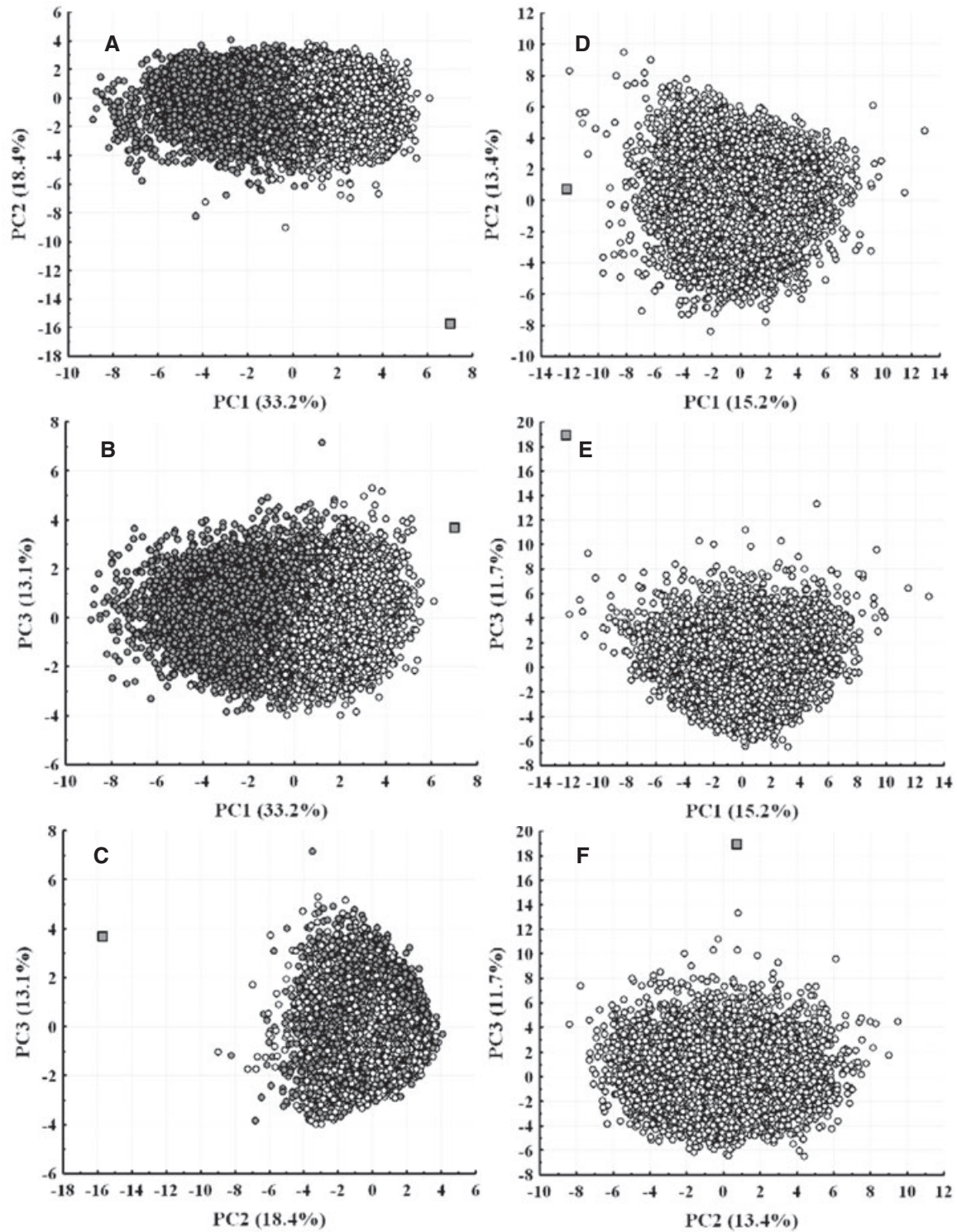

Figure 5. Prior predictive distributions of summary statistics (SuSt) used in approximate Bayesian computation analyses for species delimitation (A, B, and C) and parameter estimation (D, E, and F) of the *Liolaemus darwini* complex. PC, principal component, open dots, simulated SuSt from the four-species model; gray dots, simulated SuSt from the two-species model (A, B, and C), gray square, observed SuSt based on sequence data of four loci of the *L. darwini* complex.

per species are sampled (Ence and Carstens 2011). In comparison, we obtained lower accuracies for similar conditions (accuracy of $\sim 75\%$ at $0.5N_e$ with four loci, Fig. 3C) but this might be due to the lower θ we used in our simulations ($\theta = 7$). The low accuracy of SpeDeSTEM is consistent with the low accuracy of STEM for estimating species trees when there is limited information in the data (which is often the case in recent speciation events), leading to high uncertainty in gene trees and the estimated species tree (Leaché and Rannala 2011).

Simulations with BPP found that this method could not distinguish separate species when they diverged $0.4N_e$ generations ago without gene flow using five loci, five sequences per species, and $\theta = 10$ (mean accuracy $\sim 60\%$) but reached approximately 100% accuracy using 10 loci (Yang and Rannala 2010). Our results are consistent with previous simulations because we also obtained very high accuracies ($> 95\%$) at $0.3N_e$ when sampling four to 10 loci but with more sequences per species (20) (Fig. 3C, D). A recent, thorough evaluation of BPP under varying sampling intensities (loci and sequences), model parameters, and population models (Zhang et al. 2011) found that BPP can delimit species with only one locus when 15–20 sequences per species are sampled, similar to our simulation results (Fig. 3A). However, when there was high migration ($N_e m = 1$), BPP was unable to separate species with a single locus even at very long divergence times ($\tau = 4N_e$), in agreement with our results (see Fig. 3E), and supporting the notion that species delimitation based on a single locus (e.g., DNA barcoding approaches, Hebert et al. 2004; Hebert and Gregory 2005) will likely fail to detect new forms that are (or have) diverged with gene flow. More generally, previous simulations and our results suggest that BPP has lower accuracy in the critical range $0.1 < N_e m < 1$, unless more loci and sequences are included in the analyses.

Even though our implementation of ABC was not the most accurate SDM in this study, ABC appeared to be almost immune to the effects of gene flow for detecting lineage separation. This ideal property of ABC for species delimitation probably derives from the explicit incorporation of migration in the models and also from using two SuSt in the analyses (mean and standard deviation of MFS, see Table S1) that record information about migration regimes in populations (Wakeley and Aliacar 2001). Although ABC was less accurate than BPP, it should be noted that we specified very informative priors for BPP in the simulations (expected θ and τ matched the true values), while we used uninformative (uniform) priors for ABC. Given the significant impact of priors in these analyses (Zhang et al. 2011), we expect that the accuracy of ABC could be improved with a different prior specification (see next section). In addition, ABC might be the least computationally efficient SDMs because it spends a considerable time in the generation of prior data even for analyzing small datasets. Nonetheless, the computational advantage of ABC approaches is

fully realized when very large datasets can be summarized in a few SuSt, and/or when multiple processors can be used for generating, and subsequently, concatenating prior data from independent simulations.

All three SDMs used in this study consistently detected four separate species within the *L. darwinii* complex despite variable population sizes and speciation with gene flow in the complex (based on IMA2 estimates), both of which violate different assumptions of these SDMs. These results suggest that these methods might be robust to the effects of limited gene flow, that our study system represents an easy delimitation problem, or both. In one scenario, long divergence times combined with little or no gene flow and small population sizes facilitate species delimitation (Ence and Carstens 2011). In the opposite scenario, shallow divergence times, large population sizes, and postdivergence gene flow make species delimitation more challenging due to extensive gene tree conflict (ILS) and poorly resolved gene trees (Yang and Rannala 2010). The comparison of the demographic estimates from IMA2 and the results of the accuracy testing of SDMs based on simulations, support the idea that the *L. darwinii* complex fits the first, easy-delimitation scenario. The species-pair *L. darwinii*-N versus *L. darwinii*-S diverged $0.4N_e$ without gene flow and *L. laurenti* versus *L. grosseorum* diverged at $1.1N_e$ with very little gene flow ($N_e m \sim 0.1$), scenarios under which BPP showed approximately 100% accuracy using four loci (Fig. 3C). In addition, ABC and SpeDeSTEM were approximately 95% accurate (at $1N_e$) and approximately 60% at $0.4N_e$ (extrapolating from the accuracy at 0.3 and $0.5N_e$), suggesting that the combination of long divergence times and/or limited gene flow probably led to congruent results among the three SDMs.

IMPROVING ABC

The flexibility and ease of implementation of the ABC framework will probably encourage more systematists to use and improve its accuracy for species delimitation and parameter estimation. To improve the accuracy of the ABC method, a number of components of the approach can be adjusted, including: model complexity, number and kinds of SuSt, and parameter priors.

ABC methods can accommodate highly parameterized models and to exploit this ability to its maximum potential, more realistic models can be conceived and compared with simpler versions (Bertorelle et al. 2010). For example, population sizes could be allowed to vary between and within lineages to account for population expansion or contraction, while models including population structure can also be formulated for correctly testing between stable or varying population sizes (Peter et al. 2010). The inclusion of population substructure within lineages in these models will also help to evaluate the impact of intraspecific gene flow in maintaining species distinctness in spite of interspecific gene flow (Zhou et al. 2010).

Table 2. Model selection with AIC criteria of alternative species delimitation profiles estimated with SpeDeSTEM based on 50 subsampling replicates. Collapsed lineages are shown in parentheses. AIC, Akaike information criterion; k , number of parameters; Δ_i , AIC – AIC_{min}; ω_i , model probability. Lineages: dN, *L. darwinii*-N; dS, *L. darwinii*-S; LI, *L. laurenti*; Lg, *L. grosseorum*.

Model	Mean AIC	k	Δ_i	ω_i	Model-likelihood
dN, dS, LI, Lg	715.0534	3	0	0.986736	1
(dN-dS), LI, Lg	723.6726	2	8.61920	0.013261	0.013439
dN, dS, (LI-Lg)	739.9219	2	24.86847	3.93E-06	3.98E-06
(dN-dS), (LI-Lg)	750.2925	1	35.23914	2.20E-08	2.23E-08

Improvements of the ABC procedure might also include using priors different from the uniform distributions used in this study. Based on empirical patterns of variation in nature, the migration rate and the divergence time parameters are frequently sampled from exponential distributions whereas mutation rate parameters are often drawn from log-uniform distributions (Bertorelle et al. 2010). In addition, other kinds of SuSt can be used that are more sensitive to detecting the relative contributions of migration versus isolation in generating the observed genetic data, such as the variance of pairwise sequence differences (Wakeley 1996; Nielsen and Wakeley 2001). This SuSt might capture enough signal in the distribution of genetic variation between lineages to discriminate between speciation in isolation versus with gene flow, and it has been used in previous ABC approaches for assessing simultaneous divergence among multiple taxon pairs (Huang et al. 2011). Instead of increasing the number and dimensionality of SuSt, which can affect the accuracy and efficiency of ABC techniques (Beaumont et al. 2002; Csilléry et al. 2010a), optimal combinations of informative SuSt about the parameter of interest could be selected using a variety of approaches (Joyce and Marjoram 2008; Wegmann et al. 2009; Blum and François 2010).

SPECIES LIMITS IN THE *L. DARWINII* COMPLEX

Species delimitation analyses with three different, coalescent-based SDMs supported the distinctness of two sister lineages: *L. darwinii*-N from *L. darwinii*-S. Previously, Etheridge (2001) found some differences in male coloration (albeit not discrete differences), and possible disjunct distributions between these forms in south-central Mendoza Province. Later, based on a phylogeographic analysis of the *cyt b* mtDNA gene, Morando et al. (2004) found that populations of *L. darwinii*-S form a single, well-supported clade with shallow divergences, whereas populations of *L. darwinii*-N did not comprise a single clade, because the morphologically distinct *L. laurenti* was nested among the *L. darwinii*-N terminals. More recently, Abdala (2007) also recovered *L. darwinii*-N and *L. darwinii*-S as sister taxa relative to *L. laurenti* and *L. grosseorum* in a broad phylogenetic analysis of the *L. boulengeri* group. Although *L. laurenti* and *L. grosseorum* are already recognized as separate species given their morphological

distinctness (Etheridge 1992, 2001), new morphological analyses will be required to establish diagnostic criteria for formal description of *L. darwinii*-N as a new species because the type locality of *L. darwinii* occurs within the range of *L. darwinii*-S (Etheridge 1993).

Our study supported the distinctness of four species in the *L. darwinii* complex using coalescent-based, multilocus SDMs despite gene exchange between partially sympatric or parapatric lineages. The overlapping ranges of *L. darwinii*-S and *L. grosseorum* in the south, and at least two sympatric localities between *L. darwinii*-N and *L. laurenti* (localities 8 and 9, see Fig. 1), probably account for the high migration estimates between these nonsister lineages based on the selected IMA2 model (Table S3). More interestingly, the inference of gene flow between *L. laurenti* and *L. grosseorum* is surprising because the nearest localities between these species are separated by approximately 330 km (localities 9 and 48, Fig. 1). Further studies, combining phylogeographic and paleoclimatic niche modeling (Knowles et al. 2007; Richards et al. 2007), will be necessary to evaluate whether gene flow only occurred in the past as a result of geographic contact between the historical ranges of these species. Similar instances of occasional gene flow and hybridization have also been shown for closely related species of *Liolaemus* based on genetic and morphological data (Olave et al. 2011).

The hypothesized parthenogenetic form (a morphologically distinct collection of all-female samples), which appears nested between *L. darwinii*-N and *L. darwinii*-S, was not included in the delimitation analysis because of its possible hybrid origin (M. Morando, unpubl. data). Although this parthenogen is probably reproductively isolated from other lineages and therefore a valid new species, SDMs can still be applied to confirm the genetic distinctness of this lineage within an ABC framework via an admixture model, and/or with new likelihood-based approaches that can test for hybrid speciation (Kubatko 2009).

Conclusions

While ABC approaches are demonstrating the benefits of simultaneous model choice and parameter estimation in phylogeographic inference (Carstens and Knowles 2010), our results also suggest

that the model-based ABC framework represents an appropriate solution to the problem of species delimitation, especially in the face of divergence with gene flow. The ABC approach used in this study can delimit species while incorporating one critical parameter, the migration rate, which can potentially erase a signature of species divergence and hamper the ability to detect separate species. However, caution should be used when applying ABC because poorly fitting models can lead to biased estimates and therefore, model checking should be an integral part of the ABC methodology (Bertorelle et al. 2010; Csilléry et al. 2010a).

In addition to the coalescent-based SDMs evaluated and applied in this study, there are multiple other methods that have been introduced and used empirically with genetic data, including: clustering methods (Pritchard et al. 2000; Huelsenbeck and Andolfatto 2007; Hausdorf and Hennig 2010), networks (Chen et al. 2010; Flot et al. 2010), a mixed Yule-coalescent model (Pons et al. 2006), measures of genealogical exclusivity (Cummings et al. 2008), and non- and semi-parametric approaches (O'Meara 2010). In practice, these new SDMs enable the discovery of cryptic, evolutionary independent lineages, but traditional taxonomic practices still demand formal morphological descriptions before applying valid names to new forms (Bauer et al. 2011). Nevertheless, a genealogical and statistical perspective for discovering and describing new species will be required to achieve the ultimate goal of a phylogenetically informed and stable taxonomy (Fujita and Leaché 2011) consistent with current views about species concepts (de Queiroz 2011).

In addition to SDMs based on genetic data, other kinds of data can be used to aid in species delimitation when genetic data are unavailable or uninformative. For example, new criteria have been introduced to delimit species with ecological (Raxworthy et al. 2007; Rissler and Apodaca 2007) and morphological data (Ezard et al. 2010; Zapata and Jiménez 2012), and integrative approaches comparing patterns of divergence across multiple traits are becoming common practice for species delimitation (Harrington and Near 2012). A fully integrated approach with different types of data will consist of a single, joint analysis instead of evaluating concordance between several independent analyses. Moreover, this approach could also incorporate other processes generating gene tree discordance (i.e., gene flow, etc.) and infer species trees and species boundaries using individual-based data with uncertain species assignments (O'Meara 2010). However, there still are major challenges that new SDMs should address including the oversplitting effect due to intraspecific structure (Niemiller et al. 2012), and the delimitation of species with very few (even single) specimens in extremely rare species that appear to be rather common in nature (Lim et al. 2012).

ACKNOWLEDGMENTS

We thank two anonymous reviewers and the AE (L. Kubatko) for providing valuable criticisms that helped to improve the original manuscript. We

also thank A. Leaché and M. Hickerson for comments on an earlier draft of this manuscript. We acknowledge help from B. Noonan for ANL development and support from students and postdocs of Sites, Morando, and Avila labs throughout the completion of this study. AC thanks his graduate committee for feedback on his dissertation research/manuscripts. Specimens were collected following local regulations and permits issued by Administración de Parques Nacionales, Direcciones Provinciales de Fauna de Río Negro, Chubut, Neuquén, La Pampa, Mendoza, Catamarca, and Administración de Áreas Protegidas de Neuquén y Mendoza (Argentina). AC acknowledges financial support from the Brigham Young University Department of Biology and Graduate Studies Office through research, mentoring, and travel scholarships, as well as support from the Society for Systematic Biologists and the Society for the Study of Amphibians and Reptiles for research and travel grants. Funding for this study was provided by the National Science Foundation "Partnership for International Research and Education" award (OISE 0530267) for collaborative research on Patagonian biodiversity, granted to the following institutions (listed alphabetically): Brigham Young University, Centro Nacional Patagónico, Dalhousie University, Darwinion Botanical Institute, George Washington University, Universidad Nacional de Córdoba, Universidad Austral de Chile, Universidad Nacional del Comahue, and the Universidad de Concepción. LJA and MM acknowledge several grants under programs PIP & IBol (CONICET) and FONCYT PICT (ANPCYT) (Argentina).

LITERATURE CITED

- Abdala, C. S. 2007. Phylogeny of the *boulengeri* group (Iguania: Liolaemidae, *Liolaemus*) based on morphological and molecular characters. *Zootaxa* 1538:21–33.
- Bauer, A. M., J. F. Parham, R. M. Brown, B. L. Stuart, L. Grismer, T. J. Papenfuss, W. Böhme, J. M. Savage, S. Carranza, J. L. Grismer, et al. 2011. Availability of new Bayesian-delimited gecko names and the importance of character-based species descriptions. *Proc. R. Soc. Lond. Ser. B* 278:490–492.
- Beaumont, M. A. 2008. Joint determination of topology, divergence time and immigration in population trees. Pp. 135–154 in S. Matsamura, P. Forster, and C. Rrenfrew, eds. *Simulation, genetics and human prehistory*. McDonald Institute for Archaeological Research, Cambridge, U.K.
- . 2010. Approximate Bayesian computation in evolution and ecology. *Annu. Rev. Ecol. Evol. Syst.* 41:379–405.
- Beaumont, M. A., W. Zhang, and D. J. Balding. 2002. Approximate Bayesian computation in population genetics. *Genetics* 162:2025–2035.
- Beaumont, M. A., R. Nielsen, C. Robert, J. Hey, O. Gaggiotti, L. Knowles, A. Estoup, M. Panchal, J. Corander, M. Hickerson, et al. 2010. In defence of model-based inference in phylogeography. *Mol. Ecol.* 19: 436–446.
- Berli, P., and M. Palczewski. 2010. Unified framework to evaluate panmixia and migration direction among multiple sampling locations. *Genetics* 185:313–326.
- Berger, J. O., S. E. Fienberg, A. E. Raftery, and C. P. Robert. 2010. Incoherent phylogeographic inference. *Proc. Natl. Acad. Sci. USA* 107:E157.
- Bertorelle, G., A. Benazzo, and S. Mona. 2010. ABC as a flexible framework to estimate demography over space and time: some cons, many pros. *Mol. Ecol.* 19:2609–2625.
- Blum, M. G. B., and O. François. 2010. Non-linear regression models for approximate Bayesian computation. *Stat. Comput.* 20:63–73.
- Camargo, A., L. J. Avila, M. Morando, and J. W. Sites, Jr. 2012. Accuracy and precision of species trees: effects of locus, individual, and base-pair sampling on inference of species trees in lizards of the *Liolaemus darwini* group (Squamata, Liolaemidae). *Syst. Biol.* 61:272–288.

- Carstens, B. C., and T. A. Dewey. 2010. Species delimitation using a combined coalescent and information-theoretic approach: an example from North American *Myotis* bats. *Syst. Biol.* 59:400–414.
- Carstens, B. C., and L. L. Knowles. 2010. Navigating the unknown: model selection in phylogeography. *Models of population structure: tools for thinkers.* *Mol. Ecol.* 19:4582–4582.
- Carstens, B. C., H. N. Stoute, and N. M. Reid. 2009. An information-theoretical approach to phylogeography. *Mol. Ecol.* 18:4270–4282.
- Chen, H., M. Strand, J. L. Norenburg, S. Sun, H. Kajihara, A. V. Chernyshev, S. A. Maslakova, and P. Sundberg. 2010. Statistical parsimony networks and species assemblages in cephalotrichid nemerteans (Nemertea). *PLoS One* 5:e12885.
- Csilléry, K., M. G. Blum, O. E. Gaggiotti, and O. François. 2010a. Approximate Bayesian computation (ABC) in practice. *Trends Ecol. Evol.* 25:410–418.
- Csilléry, K., M. G. B. Blum, O. E. Gaggiotti, and O. François. 2010b. Invalid arguments against ABC: reply to A. Templeton. *Trends Ecol. Evol.* 25:490–491.
- Csilléry, K., O. François, and M. G. B. Blum. 2012. abc: an R package for approximate Bayesian computation (ABC). *Method. Ecol. Evol.* doi: 10.1111/j.2041-210X.2011.00179.x.
- Cummings, M. P., M. C. Neel, and K. L. Shaw. 2008. A genealogical approach to quantifying lineage divergence. *Evolution* 62:2411–2422.
- Degnan, J. H., and N. A. Rosenberg. 2009. Gene tree discordance, phylogenetic inference and the multispecies coalescent. *Trends Ecol. Evol.* 24:332–340.
- de Queiroz, K. 2011. Branches in the lines of descent: Charles Darwin and the evolution of the species concept. *Biol. J. Linn. Soc.* 103:19–35.
- Drummond, A. J., and A. Rambaut. 2007. BEAST: Bayesian evolutionary analysis by sampling trees. *BMC Evol. Biol.* 7(214):1–8.
- Edwards, S. V. 2009. Is a new and general theory of molecular systematics emerging? *Evolution* 63:1–19.
- Ence, D. D., and B. C. Carstens. 2011. SpedeSTEM: a rapid and accurate method for species delimitation. *Mol. Ecol. Res.* 11:473–480.
- Etheridge, R. 1992. A new psammophilus lizard of the genus *Liolaemus* (Squamata: Tropicuridae) from northwestern Argentina. *B. Mus. Reg. Sci. Nat.* 10:1–19.
- . 1993. Lizards of the *Liolaemus darwini* complex (Squamata: Iguania: Tropicuridae) in Northern Argentina. *B. Mus. Reg. Sci. Nat.* 11:137–199.
- . 2001. A new species of *Liolaemus* (Reptilia: Squamata: Tropicuridae) from Mendoza Province, Argentina. *Cuad. Herpetol.* 15:3–15.
- Ezard, T. H. G., P. N. Pearson, and A. Purvis. 2010. Algorithmic approaches to aid species' delimitation in multidimensional morphospace. *BMC Evol. Biol.* 10(175):1–11.
- Fan, H., and L. S. Kubatko. 2011. Estimating species trees using approximate Bayesian computation. *Mol. Phylogenet. Evol.* 59:354–363.
- Flot, J. F., A. Couloux, and S. Tillier. 2010. Haplowebs as a graphical tool for delimiting species: a revival of Doyle's "field for recombination" approach and its application to the coral genus *Pocillopora* in Clipperton. *BMC Evol. Biol.* 10(372):1–14.
- Fujita, M. K., and A. D. Leaché. 2011. A coalescent perspective on delimiting and naming species: a reply to Bauer et al. *Proc. R. Soc. B* 278:493–495.
- Funk, D. J., and K. E. Omland. 2003. Species-level paraphyly and polyphyly: frequency, causes, and consequences, with insights from animal mitochondrial DNA. *Annu. Rev. Ecol. Evol. Syst.* 34:397–423.
- Harrington, R. C., and T. J. Near. 2012. Phylogenetic and coalescent strategies of species delimitation in snubnose darters (Percidae: *Etheostoma*). *Syst. Biol.* 61:63–79.
- Hausdorf, B. 2011. Progress toward a general species concept. *Evolution* 65:923–931.
- Hausdorf, B., and C. Hennig. 2010. Species delimitation using dominant and codominant multilocus markers. *Syst. Biol.* 59:491–503.
- Hebert, P. D., and T. R. Gregory. 2005. The promise of DNA barcoding for taxonomy. *Syst. Biol.* 54:852–859.
- Hebert, P. D., M. Y. Stoeckle, T. S. Zemlak, and C. M. Francis. 2004. Identification of birds through DNA barcodes. *PLoS Biol.* 2:1657–1663.
- Heled, J., and A. J. Drummond. 2010. Bayesian inference of species trees from multilocus data. *Mol. Biol. Evol.* 27:570–580.
- Hey, J. 2009. On the arbitrary identification of real species. Pp. 15–28 *in* R. K. Butlin, J. Bridle, and D. Schluter, eds. *Speciation and patterns of diversity.* Cambridge Univ. Press, Cambridge, UK.
- . 2010. Isolation with migration models for more than two populations. *Mol. Biol. Evol.* 27:905–920.
- Huang, W., N. Takebayashi, Y. Qi, and M. J. Hickerson. 2011. MTML-msBayes: approximate Bayesian comparative phylogeographic inference from multiple taxa and multiple loci with rate heterogeneity. *BMC Bioinform.* 12(1):1–14.
- Hudson, R. R. 2002. Generating samples under a Wright-Fisher neutral model. *Bioinformatics* 18:337–338.
- Huelsenbeck, J. P., and P. Andolfatto. 2007. Inference of population structure under a Dirichlet process model. *Genetics* 175:1787–1802.
- Joyce, P., and P. Marjoram. 2008. Approximately sufficient statistics and Bayesian computation. *Stat. Appl. Genet. Mol. Biol.* 7(1):1–116.
- Knowles, L. L., and B. C. Carstens. 2007. Delimiting species without monophyletic gene trees. *Syst. Biol.* 56:887–895.
- Knowles, L. L., B. C. Carstens, and M. L. Keat. 2007. Coupling genetic and ecological-niche models to examine how past population distributions contribute to divergence. *Curr. Biol.* 17:940–946.
- Kubatko, L. S. 2009. Identifying hybridization events in the presence of coalescence via model selection. *Syst. Biol.* 58:478–488.
- Kubatko, L. S., B. C. Carstens, and L. L. Knowles. 2009. STEM: species tree estimation using maximum likelihood for gene trees under coalescence. *Bioinformatics* 25:971–973.
- Larkin, M. A., G. Blackshields, N. P. Brown, R. Chenna, P. A. McGettigan, H. McWilliam, F. Valentin, I. M. Wallace, A. Wilm, R. Lopez, et al. 2007. Clustal W and Clustal X version 2.0. *Bioinformatics* 23:2947–2948.
- Leaché, A. D. 2009. Species tree discordance traces to phylogeographic clade boundaries in North American fence lizards (*Sceloporus*). *Syst. Biol.* 58:547–559.
- Leaché, A. D., and M. K. Fujita. 2010. Bayesian species delimitation in West African forest geckos (*Hemidactylus fasciatus*). *Proc. R. Soc. B* 277:3071–3077.
- Leaché, A. D., and B. Rannala. 2011. The accuracy of species tree estimation under simulation: a comparison of methods. *Syst. Biol.* 60:126–137.
- Lim, G. S., M. Balke, and R. Meier. 2012. Determining species boundaries in a world full of rarity: singletons, species delimitation methods. *Syst. Biol.* 61:165–169.
- Liu, L., L. Yu, and S. V. Edwards. 2010. A maximum pseudo-likelihood approach for estimating species trees under the coalescent model. *BMC Evol. Biol.* 10(302):1–18.
- Lopes, J. S., and M. A. Beaumont. 2010. ABC: a useful Bayesian tool for the analysis of population data. *Infect. Genet. Evol.* 10:826–833.
- Lopes, J. S., D. Balding, and M. A. Beaumont. 2009. PopABC: a program to infer historical demographic parameters. *Bioinformatics* 25:2747–2749.
- Marshall, J. C., E. Arevalo, E. Benavides, J. L. Sites, and J. W. Sites, Jr. 2006. Delimiting species: comparing methods for mendelian characters using lizards of the *Sceloporus grammicus* (Squamata : Phrynosomatidae) complex. *Evolution* 60:1050–1065.
- Martin, D. P., C. Williamson, and D. Posada. 2005. RDP2: recombination detection and analysis from sequence alignments. *Bioinformatics* 21:260–262.

- Morando, M., L. J. Avila, J. Baker, and J. W. Sites, Jr. 2004. Phylogeny and phylogeography of the *Liolaemus darwini* complex (Squamata : Liolaemidae): evidence for introgression and incomplete lineage sorting. *Evolution* 58 (12):842–861.
- Nielsen, R., and J. Wakeley. 2001. Distinguishing migration from isolation: a Markov chain Monte Carlo approach. *Genetics* 158:885–896.
- Niemiller, M. L., T. J. Near, and B. M. Fitzpatrick. 2012. Delimiting species using multilocus data: diagnosing cryptic diversity in the southern cavefish, *Typhlichthys subterraneus* (Teleostei: Amblyopsidae). *Evolution* 66:846–866.
- Noonan, B., and A. D. Yoder. 2009. Anonymous nuclear markers for Malagasy plated lizards (*Zonosaurus*). *Mol. Ecol. Res.* 9:402–404.
- Nosil, P. 2008. Speciation with gene flow could be common. *Mol. Ecol.* 17:2103–2106.
- Olave, M., L. E. Martinez, L. J. Avila, J. W. Sites, Jr., and M. Morando. 2011. Evidence of hybridization in the Argentinean lizards *Liolaemus gracilis* and *Liolaemus bibronii* (Iguania: Liolaemini): an integrative approach based on genes and morphology. *Mol. Phylogenet. Evol.* 61:381–391.
- O'Meara, B. C. 2010. New heuristic methods for joint species delimitation and species tree inference. *Syst. Biol.* 59:59–73.
- Peter, B. M., D. Wegmann, and L. Excoffier. 2010. Distinguishing between population bottleneck and population subdivision by a Bayesian model choice procedure. *Mol. Ecol.* 19:4648–4660.
- Pinho, C., and J. Hey. 2010. Divergence with gene flow: models and data. *Annu. Rev. Ecol. Evol. Syst.* 41:215–230.
- Pons, J., T. G. Barraclough, J. Gomez-Zurita, A. Cardoso, D. P. Duran, S. Hazell, S. Kamoun, W. D. Sumlin, and A. P. Vogler. 2006. Sequence-based species delimitation for the DNA taxonomy of undescribed insects. *Syst. Biol.* 55:595–609.
- Posada, D. 2008. jModelTest: phylogenetic model averaging. *Mol. Biol. Evol.* 25:1253–1256.
- Pritchard, J. K., M. T. Seielstad, A. Perez-Lezaun, and M. W. Feldman. 1999. Population growth of human Y chromosomes: a study of Y chromosome microsatellites. *Mol. Biol. Evol.* 16:1791–1798.
- Pritchard, J. K., M. Stephens, and P. Donnelly. 2000. Inference of population structure using multilocus genotype data. *Genetics* 155:945–959.
- Rambaut, A., and A. J. Drummond. 2007. Tracer v1.4. Available at <http://beast.bio.ed.ac.uk/Tracer>.
- Rambaut, A., and N. C. Grassly. 1997. Seq-Gen: an application for the Monte Carlo simulation of DNA sequence evolution along phylogenetic trees. *Comput. Appl. Biosci.* 13:235–238.
- Rannala, B., and Z. Yang. 2003. Bayes estimation of species divergence times and ancestral population sizes using DNA sequences from multiple loci. *Genetics* 164:1645–1656.
- Raxworthy, C. J., C. M. Ingram, N. Rabibisoa, and R. G. Pearson. 2007. Applications of ecological niche modeling for species delimitation: a review and empirical evaluation using day geckos (*Phelsuma*) from Madagascar. *Syst. Biol.* 56:907–923.
- Richards, C. L., B. C. Carstens, and L. L. Knowles. 2007. Distribution modelling and statistical phylogeography: an integrative framework for generating and testing alternative biogeographical hypotheses. *J. Biogeogr.* 34:1833–1845.
- Rissler, L. J., and J. J. Apodaca. 2007. Adding more ecology into species delimitation: ecological niche models and phylogeography help define cryptic species in the black salamander (*Aneides flavipunctatus*). *Syst. Biol.* 56:924–942.
- Stephens, M., N. Smith, and P. Donnelly. 2001. A new statistical method for haplotype reconstruction from population data. *Am. J. Hum. Genet.* 68:978–989.
- Templeton, A. R. 2009. Statistical hypothesis testing in intraspecific phylogeography: nested clade phylogeographical analysis vs. approximate Bayesian computation. *Mol. Ecol.* 18:319–331.
- . 2010a. Coherent and incoherent inference in phylogeography and human evolution. *Proc. Natl. Acad. Sci. USA* 107:6376–6381.
- . 2010b. Correcting approximate Bayesian computation. *Trends Ecol. Evol.* 25:488–489.
- Thomson, R. C., I. J. Wang, and J. R. Johnson. 2010. Genome-enabled development of DNA markers for ecology, evolution and conservation. *Mol. Ecol.* 19:2184–2195.
- Wakeley, J. 1996. The variance of pairwise nucleotide differences in two populations with migration. *Theor. Popul. Biol.* 49:39–57.
- Wakeley, J., and N. Aliacar. 2001. Gene genealogies in a metapopulation. *Genetics* 145:847–855.
- Wegmann, D., C. Leuenberger, and L. Excoffier. 2009. Efficient approximate Bayesian computation coupled with Markov chain Monte Carlo without likelihood. *Genetics* 182:1207–1218.
- Wiens, J. J. 2007. Species delimitation: new approaches for discovering diversity. *Syst. Biol.* 56:875–878.
- Wiens, J. J., and T. A. Penkrot. 2002. Delimiting species using DNA and morphological variation and discordant species limits in spiny lizards (*Sceloporus*). *Syst. Biol.* 51:69–91.
- Yang, Z., and B. Rannala. 2010. Bayesian species delimitation using multilocus sequence data. *Proc. Natl. Acad. Sci. USA* 107:9264–9269.
- Zapata, F., and I. Jiménez. 2012. Species delimitation: inferring gaps in morphology across geography. *Syst. Biol.* 61:179–194.
- Zhang, C., D.-X. Zhang, T. Zhu, and Z. Yang. 2011. Evaluation of a Bayesian coalescent method of species delimitation. *Syst. Biol.* 60:747–761.
- Zhou, Y. F., R. J. Abbott, Z. Y. Jiang, F. K. Du, R. I. Milne, and J. Q. Liu. 2010. Gene flow and species delimitation: a case study of two pine species with overlapping distributions in southeast China. *Evolution* 64:2342–2352.

Associate Editor: L. Kubatko

Supporting Information

The following supporting information is available for this article:

Figure S1. Species tree of the *L. darwinii* complex based on a Bayesian analysis in *BEAST.

Table S1. Summary statistics (SuSt) of the priors, the observed data, and the posterior of ABC analyses for species delimitation.

Table S2. Summary statistics (SuSt) of the prior, the observed data, and the posterior of ABC analyses for parameter estimation.

Table S3. Model selection with AIC criteria of alternative demographic models estimated with IMA2.

Appendix S1.

Figure S1. Number of references published between 1981 and 2010 retrieved from the ISI Web of Science that contained the keyword "species delimitation".

Figure S2. Number of references published between 1992 and 2010 retrieved from the ISI Web of Science that contained the keyword "approximate bayesian computation".

Appendix S2. List of specimens sequenced for this study.

Supporting Information may be found in the online version of this article.

Please note: Wiley-Blackwell is not responsible for the content or functionality of any supporting information supplied by the authors. Any queries (other than missing material) should be directed to the corresponding author for the article.