



Characterization of small-spored *Alternaria* from Argentinean crops through a polyphasic approach



Lucía da Cruz Cabral^{a,*}, Marcela Rodruigero^b, Sebastián Stenglein^c, Kristian Fog Nielsen^d, Andrea Patriarca^a

^a Universidad de Buenos Aires, Facultad de Ciencias Exactas y Naturales, Departamento de Química Orgánica, Laboratorio de Microbiología de Alimentos, Buenos Aires, Argentina

^b Universidad de Buenos Aires, Facultad de Ciencias Exactas y Naturales, Departamento de Ecología, Genética y Evolución, Instituto de Ecología, Genética y Evolución de Buenos Aires (IEGEB - CONICET/UBA), Grupos de Investigación en Filogeografía y Filogenias Moleculares, Buenos Aires, Argentina

^c Laboratorio de Biología Funcional y Biotecnología (BIOLAB)-CICBA-INBIOTEC, CONICET, Área de Microbiología, Facultad de Agronomía, UNCPBA, Azul, Buenos Aires, Argentina

^d Technical University of Denmark, Department of Systems Biology, Kgs. Lyngby, Denmark

ARTICLE INFO

Keywords:

Alternaria
Endopolygalacturonase gene
Polyphasic approach
Metabolites profile
Food

ABSTRACT

Small-spored *Alternaria* have been isolated from a wide variety of food crops, causing both economic losses and human health risk due to the metabolites produced. Their taxonomy has been discussed widely, but no scientific consensus has been established in this field to date. Argentina is a major exporter of agricultural products, so it is essential to thoroughly understand the physiological behaviour of this pathogen in a food safety context. Thus, the objective of this work was to characterize small-spored *Alternaria* spp. obtained from tomato fruits, pepper fruits, wheat grains and blueberries from Argentina by a polyphasic approach involving metabolomic and phylogenetic analyses based on molecular and morphological characters. Morphological analysis divided the population studied into three groups; *A. arborescens* sp.-grp., *A. tenuissima* sp.-grp., and *A. alternata* sp.-grp. However, when these characters were simultaneously analysed with molecular data, no clearly separated groups were obtained. Haplotype network and phylogenetic analysis (both Bayesian and maximum parsimony) of a conserved region yielded the same result, suggesting that all isolates belong to the same species. Furthermore, no correlation could be established between morphological species-groups and a metabolite or group of metabolites synthesized. Thus, the whole set of analyses carried out in the present work supports the hypothesis that these small-spored *Alternaria* isolates from food belong to the same species. Identification at species level through classical morphology or modern molecular techniques does not seem to be a useful tool to predict toxicological risk in food matrices. The detection of any small-spored *Alternaria* from Section *Alternaria* (D.P. Lawr., Gannibal, Peever & B.M. Pryor 2013) in food implies a potential toxicological risk.

1. Introduction

Alternaria is a ubiquitous fungal genus, associated with a wide variety of substrates including seeds, plants, animals, and soil. Due to its capability to colonize plants, either as pathogen or saprophyte, it causes economic losses to several crops worldwide. In Argentina, *Alternaria* spp. have been reported as contaminants of wheat, blueberries, tomato fruit, tomato puree, peaches, apples, sorghum, rice, soybean seeds and citrus fruits (Brogi et al., 2007; Greco et al., 2012; Patriarca et al., 2007; Peres et al., 2003; Pose et al., 2004; Pose et al., 2010; Robiglio and Lopez, 1995; Somma et al., 2011).

Morphological identification at the species level for *Alternaria* is

currently based on the taxonomic key proposed by Simmons (2007), which describes 275 species organized in 13 species-groups (sp.-grp.), according to colony morphology on standardized media and conidial chain branching patterns. Subsequent molecular studies have supported many of these groups as monophyletic lineages (Hong et al., 2006; Pryor and Bigelow, 2003; Pryor and Gilbertson, 2000). However, some *Alternaria* morphospecies may vary depending on the culture media, relative humidity and light intensity (Simmons, 1992). In particular, small-spored species closely related to *A. alternata* (members of *A. alternata* sp.-grp., *A. tenuissima* sp.-grp. and *A. arborescens* sp.-grp.) have been thoroughly studied because morphological characters are insufficient for species delimitation since they are strongly influenced by

* Corresponding author.

E-mail address: ldacruzcabral@qo.fcen.uba.ar (L. da Cruz Cabral).

small changes in the environment (Andrew et al., 2009). In addition, most characters frequently overlap among these species.

Sequencing of classical conserved regions, which have proved to be useful in the identification of other fungal genera (e.g. ITS, mtSSU, mtLSU, β -tubulin, actin, calmodulin), provided no resolution among these taxa (Chou and Wu, 2002; Peever et al., 2004; Pryor and Gilbertson, 2000; Serdani et al., 2002; Stewart et al., 2013). Lately, sequencing of alternative regions has been explored, such as a segment of an endopolygalacturonase (*endoPG*) gene; the *Alternaria* major allergen 1 (*Alt a1*) gene; translation machinery associated protein (*TMA22*); the CDP-diacylglycerol- glycerol-3-phosphate 3-phosphatidytransferase (*PGS1*); the catalytic subunit of DNA polymerase zeta (*REV3*) and two anonymous noncoding regions, OPA10-2 and OPA1-3 (Andrew et al., 2009; Armitage et al., 2015). In particular, *endoPG* showed variability among species isolated from citrus (Andrew et al., 2009; Peever et al., 2004), and has been used so far to characterize small-spored *Alternaria* from these and other substrates (Armitage et al., 2015; Stewart et al., 2013; Stewart et al., 2014).

Even though *Alternaria* is frequently isolated from Argentinean crops, little is known about the variability and differentiation of its populations in this country. This is important since some species are allergenic and may be opportunistic human pathogens in immunocompromised patients (Armitage et al., 2015). In addition, this genus is well known for its ability to synthesize diverse secondary metabolites, some of them recognized as mycotoxins, such as alternariol (AOH), alternariol monomethyl ether (AME), tenuazonic acid (TeA), altenuene (ALT), and altertoxins I, II, III (ATX-I, -II, -III) (Alexander et al., 2011; Ostry, 2008). Their toxic effects include human haematological disorders, oesophageal cancer and mutagenic activity (Andersen et al., 2015; Logrieco et al., 2009; Ostry, 2008). Other important bioactive compounds produced by *Alternaria* sp. include tentoxin (TEN) and dihydrotentoxin (DHTEN), both with phytotoxic activities; altenuisol (ALS), reported to have toxic effects in mammalian cells *in vitro* and altenusin (ALN), with antibacterial, antifungal and antiparasitic activities (Cota et al., 2008; Lou et al., 2013; Nemecek et al., 2012). In addition, some small-spored *Alternaria* species are able to produce host-specific toxins (HSTs), which are toxic to susceptible plants, such as AM-toxin in apple; AAL-toxins in tomato; AF-toxin in strawberry; and AK-toxin in Japanese pear (Lou et al., 2013; Tsuge et al., 2013).

Most Argentinean *Alternaria* isolates from food belong to small-spored *Alternaria* groups, with high metabolomic potential, implying a consequent toxicological risk for consumers. Considering Argentina is a major exporter of agricultural products worldwide, it is essential to thoroughly understand the physiological behaviour of this pathogen in a food safety context. Moreover, the European Food Safety Authority recently published a report on *Alternaria* toxins, considering their toxicokinetics, natural occurrence, and influence of food and feed processing in order to discuss the establishment of guideline limits (Alexander et al., 2011).

The aim of this work was to characterize small-spored *Alternaria* spp. isolates obtained from edible parts of crops of agronomical importance in Argentina using a polyphasic approach, involving metabolomic and phylogenetic analyses based on molecular and morphological characters. These data are crucial to the development of control strategies related to pest management and accumulation of toxic metabolites in foods.

2. Materials and methods

2.1. Fungal strains

Forty-five *Alternaria* strains were isolated from four Argentinean crops during the period 2010–2013. Fourteen strains were obtained from symptomatic tomato fruit (*Lycopersicon esculentum*, “T”), 14 from symptomatic red pepper (*Capsicum annuum*, “P”), and two from symptomless blueberries of the O’Neal variety (*Vaccinium angustifolium*; “B”),

all collected from organic producers in La Plata, Buenos Aires province. The remaining 15 isolates were obtained from symptomless wheat grains (*Triticum aestivum*, “W”) cultivated in the Argentinean wheat production area known as V-South (La Pampa and South West Buenos Aires provinces). Isolation was performed in DCMA (Dichloran Chloramphenicol Malt Agar) plates after 5–7 days of incubation at 25 °C. *Alternaria* isolates were kept in V8 agar plates. Three representative strains were used in this study: *A. alternata* EGS 34016, *A. tenuissima* EGS 34015, and *A. arborescens* EGS 39128, for comparison purposes.

2.2. Morphological characterization

Traditional morphological classification of *Alternaria* strains was performed according to Simmons (2007). Briefly, isolates were inoculated in Potato Carrot Agar (PCA) plates and incubated for seven days at 25 °C under an alternating light cycle consisting of 8 h of cool-white fluorescent daylight and 16 h of darkness. The three-dimensional sporulation pattern of the cultures was examined directly on the plates using a stereo-microscope ($\times 80$). Further examination (length of primary and secondary conidiophores, secondary conidiophores shape, conidial shapes, sizes, colours and ornamentation) was done at $\times 400$ magnification on slide preparations made by collecting spores from colony surface with transparent adhesive tape mounted in lactic acid. Colony characteristics (e.g. color, texture and diameter) were recorded from plates after the incubation period. The complete list of morphological characters registered is shown in Table S1.

2.3. Secondary metabolite production

For metabolite profiling, Dichloran Rose Bengal Yeast Extract Sucrose agar (DRYES, Samson et al., 2010) plates were inoculated at three points and incubated 14 days at 25 °C in darkness. Extraction was carried out on a micro-scale using a modified method for *Alternaria* metabolites (Andersen et al., 2005). Three agar plugs were cut from the centre of the three colonies and the nine plugs were placed in a 4 mL vial. Then 1 mL ethyl acetate containing 1% formic acid (vol/vol) was added to each vial and the plugs were extracted by sonication for 30 min. The extract was transferred to a clean 2 mL vial, evaporated to dryness in a gentle stream of N₂ and re-dissolved in 400 μ L methanol. The methanol extract was filtered through a 0.45 μ m PTFE filter into a clean 2 mL vial and kept at -18 °C prior to HPLC analysis.

Analyses were performed using ultra-high-performance liquid chromatography (UHPLC) with a diode array detector (DAD) and high-resolution (HR) maXis HD QTOF mass spectrometer (MS) (Bruker Daltonics, Bremen, Germany) equipped with an ESI source and connected to an Ultimate 3000 UHPLC system (Dionex, Sunnyvale, USA) equipped with a Kinetex 2.6- μ m C₁₈, 100 mm \times 2.1 mm column (Phenomenex, Torrance, CA). A linear water-acetonitrile gradient was used (buffered with 20 mM formic acid) starting from 10% (vol/vol) acetonitrile and increased to 100% in 10 min, maintained for 3 min before returning to the starting conditions. MS was performed in ESI⁺ and ESI⁻ in the scan range *m/z* 100–1000, with a mass accuracy < 1.5 ppm. UV/VIS spectra were collected at wavelengths from 200 to 700 nm. Data processing was performed using DataAnalysis 4.2 and TargetAnalysis 1.3 (Bruker Daltonics) by the aggressive dereplication approach (Klitgaard et al., 2014). For this study, a database of 678 known and putative compounds from *Alternaria*, *Lewia*, *Ulocladium* and other related genera were used, tentatively identifying them based on accurate mass (deviation < 1.5 ppm) and isotopic pattern (isotope fit < 50) and UV/Vis data (Klitgaard et al., 2014). For compounds not available as reference standards MS/HRMS were further conducted to match fragmentations with the molecular structure (Andersen et al., 2015; Nielsen and Larsen, 2015). All major peaks (observed in the BP chromatograms) not tentatively identified by the approach were added to the search list as unknown compounds for mapping. All major peaks (known and unknown) for the 48 extracts, corresponding to 45 wild

isolates and 3 representative strains, were subsequently ordered in a data matrix.

2.4. DNA analysis

Genomic DNA was extracted from mycelia grown on 9 cm 7-day-old PCA plates, following the method described by Stenglein and Balatti (2006). Briefly, mycelia were frozen in liquid nitrogen and ground in a mortar into a fine powder, which was mixed with 800 μ L of CTAB extraction buffer + β -mercaptoethanol + 0.01 g PVP. The slurry was heated at 60 °C for 30 min. Then, one volume of chloroform:isoamyl alcohol (12 + 1 v/v) was added, vortexed and centrifuged at 10000g for 7 min. The aqueous phase containing the DNA was transferred to a new tube and DNA precipitated overnight by adding isopropanol. The extract was centrifuged at 10,000g for 7 min. The pellet was washed with 200 μ L 10 mM ammonium acetate-75% ethanol (10,000g, 7 min) and then with cold 70% ethanol (10,000g, 7 min). Finally, the pellet was dried and re-dissolved in TE buffer. PCR amplification of a segment of the endopolygalacturonase gene (*endoPG*) was assayed using primers PG3 (5'-TACCATGGTTCTTTCCGA-3') and PG2b (5'-GAGAAATTCRC-ARTCRCTCYTGRTT-3'), according to Andrew et al. (2009). Each PCR reaction was performed in a 25 μ L mixture that contained 1–15 ng of genomic DNA, 5 mM MgCl₂, 0.03 mM of each dNTP, 10 \times PCR buffer, 0.4 mg/mL cresol, 1 μ M each of forward and reverse primers, 1 u Taq DNA polymerase (Higway Molecular Biology-InBio-UNICEN-Tandil), 0.0005% (w/v) Tween 20 and 0.0005% (w/v) Nonidet P-40. PCR reactions were carried out in a XP thermal cycler (BioerTechnology Co.), using the following cycling protocol: an initial denaturation step of 95 °C for 2 min; 29 cycles of 95 °C for 30 s, 55 °C for 30 s, 72 °C for 45 s; final extension of 72 °C for 2 min. Successful amplifications were confirmed by agarose gel electrophoresis. PCR products were purified with the PureLink™ PCR Purification kit (Invitrogen, Life Technologies, Carlsbad, CA, USA) and quantified with Qubit™ Fluorometer (Invitrogen, Life Technologies, Carlsbad, CA, USA) following the manufacturer's directions. The amplicons were sequenced commercially in both directions (Macrogen, Korea).

2.5. Data treatment

2.5.1. Metabolite data

A dendrogram was obtained based on the 48 strains and their production of 100 metabolites with both known and unknown chemical structures (67 known and 33 unknown compounds). The presence or absence of a particular metabolite for each strain was scored as 1 or 0, respectively. The binary matrix was subjected to cluster analysis using InfoStat v. 2014 software (Grupo InfoStat, FCA, Universidad Nacional de Córdoba, Argentina) without standardization. For distance matrices construction, different methods were assayed (Jaccard, Yule-Kendall and Simple Matching). The clustering method was UPGMA. The most appropriate dendrogram was selected using the cophenetic correlation coefficient.

2.5.2. Morphological phylogeny

Morphological dataset was analysed through maximum parsimony. Heuristic searches were conducted using TNT v. 1.1 (Goloboff and Catalano, 2016; Goloboff et al., 2008). Equal weights and no additive characters were used, and gaps were treated as missing data. Before searches, all uninformative characters were deactivated. The analyses were done using Multiple TBR + TBR applied to a series of 1000 random addition sequences retaining 10 cladograms per replicate. Bootstrap values were calculated from 1000 replicates. *Alternaria tomato* isolate was used as outgroup.

2.5.3. Sequences alignment and phylogenetic analysis

DNA sequences were edited using BioEdit v7.1.3.0 (Hall, 1999). Sequences were aligned with ClustalW (Thompson et al., 1994).

Alternaria tomato isolate BMP 2031 (GenBank Accession No. KF699423) was used as outgroup (Stewart et al., 2014).

In order to infer the relationships among haplotypes and assess levels of genetic diversity, a haplotype network was constructed using Software TCS v1.21 (Clement et al., 2000). We also accomplished a phylogenetic analysis using one representative sequence per haplotype and the reference strains. Two different methods were applied, Bayesian and maximum parsimony approaches. For Bayesian inference, the optimal model of nucleotide substitution was estimated with jModelTest v2.1.7 (Darriba et al., 2012; Posada, 2008) through Phylemon v2.0 (Sánchez et al., 2011) on the bases of the Bayesian Information Criterion (BIC), which was K80. Bayesian analysis were performed in MrBayes v3.2.3 (Ronquist et al., 2012) using the 'Metropolis-coupled Markov chain Monte Carlo' (MCMCMC) algorithm. Two independent analyses using four chains, one cold and three incrementally heated, were run using a random starting tree over 1,000,000 generations sampling every 500 generations. The average standard deviation of split frequencies stabilized to a difference of < 1% and the software Tracer v1.6.0 (Rambaut et al. 2003–2013) were used to assess convergence of the cold chain. The initial 250,000 generations from each run were discarded as "burn-in" when summarizing tree parameters and topology, which was visualized with FigTree v1.4.2 (Rambaut 2006–2014). Maximum parsimony analysis was performed under a traditional search in TNT v1.1 (Goloboff et al. 2008) as explained above, and using the same clade support parameters as before.

Finally, Bayesian and maximum parsimony phylogeny were also inferred for worldwide *endoPG* sequences in order to evaluate possible geographic isolation. For this purpose, sequences reported by Stewart et al. (2014) were retrieved from GenBank (see Accession Numbers in Table 1). Both phylogenetic analyses were performed as described before, using one representative sequence of each haplotype from Fig. 1A in Stewart et al. (2014), and K80 as model of nucleotide substitution for Bayesian inference.

2.5.4. Combined analysis with sequences and morphological data

To perform Bayesian phylogenetic analysis considering both morphological and *endoPG* datasets, a partitioned algorithm was used to account for heterogeneity in MrBayes. For the morphological dataset, the model was set considering the variable number of possible states for each character with default parameters (Nylander et al. 2004; Ronquist et al. 2012).

3. Results

3.1. Morphological characterization

Eleven out of 45 isolates (seven from tomato fruit, three from wheat and one from pepper) were identified as belonging to the morphological group "L" (*A. arborescens* sp.-grp.) from the manual by Simmons (2007). The main characteristics were long primary conidiophores with a terminal cluster of branching conidial chains. Secondary conidiophores originating mostly from conidial apex were regularly observed. Colonies on DRYES were sulcate and dark green. Twenty-nine isolates (the two from blueberries, ten from pepper, ten from wheat and seven from tomato fruit) exhibited a sporulation pattern corresponding to the *A. tenuissima* sp.-grp. (group "H" in Simmons (2007)), characterized by three-dimensional sporulation patterns with conidia formed in relatively long chains of conidia (up to 15), borne from primary conidiophores of varying length. Secondary conidiophores were infrequent, but when present, they mainly originated from the conidial body. On DRYES these strains exhibited light green to greyish colonies. Two more isolates (from pepper and wheat) presented short primary conidiophores with multi-branched chains of 4–10 conidia, frequently with lateral secondary conidiophores and were identified as *A. alternata* sp.-grp. (group "J" from the manual). Colonies on DRYES were sulcate and dark green, similar to "L" group. The three remaining isolates exhibited

Table 1

Alternaria isolates, source, morphological classification, haplotype ID and GenBank accession number. Isolates marked as (*) are the representative haplotypes selected for the subsequent analyses.

Code	Substrate	sp.-grp. ^a	Haplotype*	GenBank accession number	Country of origin	References
alter34016_J	Peanut	J	4*	KY969535	India	Simmons, 2007
arbo39128_L	Tomato	L	5c*	KY969538	USA	Simmons, 2007
ten34015_H	Carnation	H	3*	KY969552	United Kingdom	Simmons, 2007
B_31_H	Blueberry	H	2	KY969553	Argentina	This study
B_32_H	Blueberry	H	2	KY969554	Argentina	This study
P_33_H	Pepper	H	3*	KY969555	Argentina	This study
P_34_H	Pepper	H	3	KY969556	Argentina	This study
P_35_H	Pepper	H	3	KY969557	Argentina	This study
P_36_H	Pepper	H	3	KY969558	Argentina	This study
P_37_H	Pepper	H	3	KY969559	Argentina	This study
P_38_L	Pepper	L	5e*	KY969539	Argentina	This study
P_39_J	Pepper	J	5f*	KY969536	Argentina	This study
P_40_H	Pepper	H	5d*	KY969560	Argentina	This study
P_41_sp	Pepper	sp	5e	KY969549	Argentina	This study
P_42_H	Pepper	H	3	KY969561	Argentina	This study
P_43_H	Pepper	H	3	KY969562	Argentina	This study
P_44_sp	Pepper	sp	5d	KY969550	Argentina	This study
P_45_H	Pepper	H	3	KY969563	Argentina	This study
P_46_H	Pepper	H	3	KY969564	Argentina	This study
T_1_H	Tomato	H	2*	KY969582	Argentina	This study
T_10_L	Tomato	L	5e	KY969543	Argentina	This study
T_11_H	Tomato	H	2	KY969567	Argentina	This study
T_12_H	Tomato	H	2	KY969568	Argentina	This study
T_2_L	Tomato	L	5b*	KY969581	Argentina	This study
T_3_L	Tomato	L	5a*	KY969540	Argentina	This study
T_47_L	Tomato	L	5d	KY969544	Argentina	This study
T_48_L	Tomato	L	5c*	KY969545	Argentina	This study
T_49_H	Tomato	H	3	KY969569	Argentina	This study
T_5_H	Tomato	H	5e	KY969565	Argentina	This study
T_50_H	Tomato	H	2	KY969570	Argentina	This study
T_7_L	Tomato	L	5d	KY969541	Argentina	This study
T_8_H	Tomato	H	3	KY969566	Argentina	This study
T_9_L	Tomato	L	5e	KY969542	Argentina	This study
W_14_J	Wheat	J	5g*	KY969537	Argentina	This study
W_16_H	Wheat	H	2	KY969571	Argentina	This study
W_18_H	Wheat	H	3	KY969572	Argentina	This study
W_20_H	Wheat	H	3	KY969573	Argentina	This study
W_21_H	Wheat	H	2	KY969574	Argentina	This study
W_22_L	Wheat	L	2	KY969546	Argentina	This study
W_23_L	Wheat	L	5d	KY969547	Argentina	This study
W_25_sp	Wheat	sp	2	KY969551	Argentina	This study
W_26_H	Wheat	H	5e	KY969575	Argentina	This study
W_29_H	Wheat	H	3	KY969576	Argentina	This study
W_51_H	Wheat	H	2	KY969577	Argentina	This study
W_52_H	Wheat	H	1*	KY969578	Argentina	This study
W_53_L	Wheat	L	5e	KY969548	Argentina	This study
W_54_H	Wheat	H	3	KY969579	Argentina	This study
W_55_H	Wheat	H	2	KY969580	Argentina	This study
A. tomato_2031	Tomato	D-3	Outgroup	KF699423.1	Unknown	Stewart et al., 2014
ST_H10_C2	Citrus fruit	J	–	KF699418.1	Argentina	Stewart et al., 2014
ST_H12_C1	Citrus fruit	J	–	KF699415.1	Israel	Stewart et al., 2014
ST_H6_C3	Citrus fruit	J	–	KF699412.1	Italy	Stewart et al., 2014
ST_H8_C1	Citrus fruit	J	–	KF699411.1	Italy	Stewart et al., 2014
ST_H11_C1	Citrus fruit	J	–	KF699409.1	Spain	Stewart et al., 2014
ST_H1_C3	Citrus fruit	J	–	KF699404.1	Iran	Stewart et al., 2014
ST_H2_C3	Citrus fruit	J	–	KF699403.1	Iran	Stewart et al., 2014
ST_H4_C3	Citrus fruit	J	–	KF699399.1	Peru	Stewart et al., 2014
ST_H5_C3	Citrus fruit	J	–	KF699398.1	Peru	Stewart et al., 2014
ST_H13_C3	Citrus fruit	J	–	KF699394.1	Turkey	Stewart et al., 2014
ST_H3_C3	Citrus fruit	J	–	KF699393.1	South Africa	Stewart et al., 2014
ST_H9_C2	Citrus fruit	J	–	KF699391.1	Brazil	Stewart et al., 2014
ST_H7_C3	Citrus fruit	J	–	KF699390.1	Australia	Stewart et al., 2014

Sample code for citrus strains: reference work_original haplotype_original clade, according to Fig. 1A from Stewart et al. (2014).

^a Morphological classification in species-group according to Simmons (2007).

intermediate characteristics among the three mentioned groups and were referred to as *Alternaria* sp.

To objectively organise micro and macro examinations, a morphological matrix including reference strains was assembled (Table S2) and a parsimony tree was constructed (Fig. S1). The analysis yielded 1257 trees 152 steps long. A consensus tree showed only two groups with

extreme low support.

3.2. Cluster analysis of metabolite profiles

A total of 71 secondary metabolites produced by *Alternaria* from food substrates were detected; 26 corresponded to known and 45 to

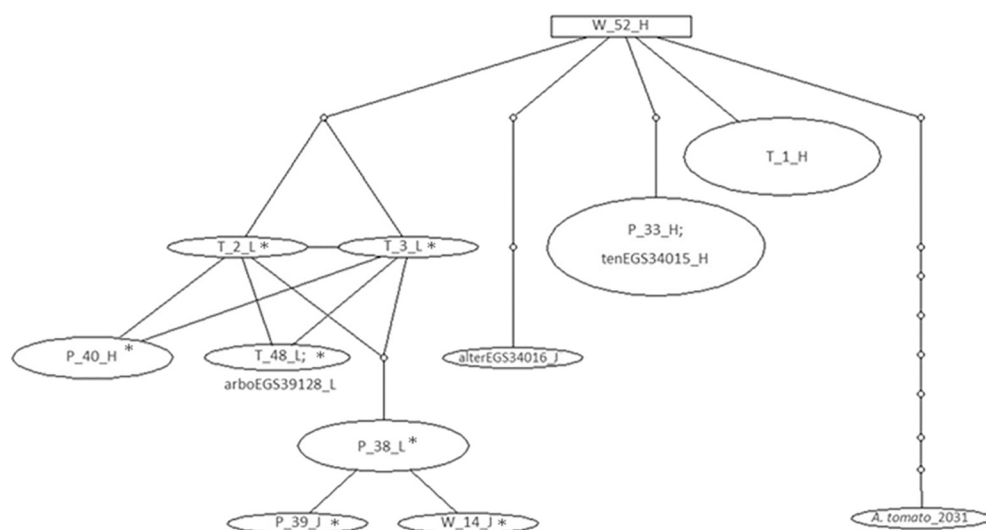

Fig. 1. Haplotype network constructed with 45 Argentinean *Alternaria* strains and three representative strains. Isolates belonging to each haplotype can be found in Table 1. The ancestral haplotype is represented as a square. Sample codes: substrate code_strain ID_species group ID, according to Table 1. Substrate code: B: blueberry; P: pepper; T: tomato; W: wheat. Species-group code: H: *A. tenuissima* sp.-grp.; J: *A. alternata* sp.-grp.; L: *A. arborescens* sp.-grp.; sp.: *Alternaria* sp. Haplotypes marked as (*) belong to the haplogroup HG-5.

unknown compounds.

Secondary metabolites suspected as mycotoxins were produced by most of the isolates belonging to the four substrates studied. AOH and AME were produced by all the *Alternaria* strains, and ALT by 44 out of 45 isolates. TeA and its isomers (valine tenuazonic acid, norvaline tenuazonic acid and isopropyl tetramic acid) were also frequently found in all species-groups except for *A. alternata* sp.-grp. TeA was produced by 32 and any of its isomers by 31 out of 45 isolates. In addition, ALS and ALN were detected in isolates from all the morphological species-groups (29 and 22 isolates, respectively), while the phytotoxins TEN and DHTEN were produced by all but the *A. alternata* sp.-grp. (26 and 16 isolates, respectively). The more toxic ATXs were detected less frequently; ATX-I was produced by 12 isolates, ATX-II by 5 and ATX-III was identified in only one strain. Interestingly, the three ATXs were only synthesized by isolates belonging to *A. tenuissima* sp.-grp. It is worth highlighting that all the strains were able to produce at least three metabolites with proven bioactivity, while 31% of the isolates synthesized six of these bioactive compounds. On the other hand, none of the isolates was able to produce host-specific toxins (HSTs) such as AM, AF, AAL or AK toxins under the studied conditions (data not shown). The list of bioactive compounds produced by *Alternaria* isolates is shown in Table 2. The complete list of metabolites detected for each

Table 2

Number of *Alternaria* isolates producer of bioactive metabolites *in vitro*. Numbers in brackets indicate total number of isolates in the correspondent column.

Metabolite	Total <i>Alternaria</i> producers (45)	<i>A. arborescens</i> sp.-grp. (11)	<i>A. alternata</i> sp.-grp. (2)	<i>A. tenuissima</i> sp.-grp. (29)	<i>Alternaria</i> sp. (3)
AOH	45	11	2	29	3
AME	45	11	2	29	3
ALT	44	11	2	28	3
TeA	32	7	0	24	1
Iso-TeA	31	7	0	23	1
ALS	29	10	2	16	1
TEN	26	6	0	19	1
ALN	22	5	2	13	2
DHTEN	16	1	0	15	0
ATX-I	12	0	0	12	0
ATX-II	5	0	0	5	0
ATX-III	1	0	0	1	0

AOH: alternariol; AME: alternariol monomethylether; ALT: altenuen; TeA: tenuazonic acid; Iso-TeA: TeA derivative (isoleucine substituted by valine or norvaline); ALS: Altenuisol; TEN: Tentoxin; ALN: Altenuisin; DHTEN: Dihydrotentoxin; ATX-I: Altertoxin-I; ATX-II: Altertoxin-II; ATX-III: Altertoxin-III.

isolate can be seen in Table S3.

Clustering generated by UPGMA using the Jaccard distance yielded the highest cophenetic coefficient (0.804), and is shown in Fig. 2. No correlation could be established between either source or morphological species-group and a metabolite or group of metabolites synthesized.

3.3. EndoPG phylogeny

Amplification of the partial endopolygalacturonase gene (*endoPG*) yielded amplicons that varied in length from 418 to 470 bp. Alignment length was 473 bp. *EndoPG* sequencing of 45 *Alternaria* isolates from different food matrices revealed a total of 11 haplotypes (GenBank accession numbers KY969535 to KY969582, Table 1). Haplotype network can be seen in Fig. 1. The ancestral haplotype (“W_52_H”, depicted as a square in the network) consisted in one isolate from wheat morphologically classified in “H” from the Simmons manual. One of its derivatives, haplotype “T_1_H”, comprises six isolates from wheat, four from tomato and two from blueberries belonging mainly to the “H” Simmons species-group, except for one isolate from the “L” group and one identified as *Alternaria* sp. Haplotype “P_33_H” included 15 “H” isolates obtained from pepper, wheat and tomato (nine, four and two, respectively) and the reference strain *A. tenuissima* EGS 34015. *Alternaria alternata* EGS34016 was a separate haplotype. The remaining isolates showed to be more related to each other than with the above mentioned, forming a haplogroup named as HG-5. This group comprises seven haplotypes. Two of them (“T_2_L” and “T_3_L”) consisted of one isolate each, both “L” from tomato. Another (“T_48_L”) consisted in two isolates belonging to the same species-group, being one of them the reference strain (*A. arborescens* EGS 39128) and the other from tomato fruit. Two other haplotypes (“P_39_J” and “W_14_J”) presented only one isolate each. Haplotype “P_40_H” involved three “L” strains, one “H” and one *Alternaria* sp. acquired from pepper, wheat and tomato (two, one and two, respectively). The remaining seven isolates of this haplotype (“P_38_L”) were morphologically identified as *A. arborescens* sp.-grp. (4), *A. tenuissima* sp.-grp. (2) and *Alternaria* sp. (1), and were obtained from pepper, wheat and tomato (2, 2 and 3, respectively). Overall, haplotype network depicts low levels of genetic diversity within Argentinean isolates of *Alternaria*, and there is no correspondence between haplotypes and host plants. We selected one sequence representing each haplotype for subsequent phylogenetic analyses (marked as * in Table 1).

Bayesian analysis tree topology is shown in Fig. 3. In addition, maximum parsimony analysis retrieved one tree 24 steps long (Fig. S2). Both topologies agree with relationships depicted by the haplotype

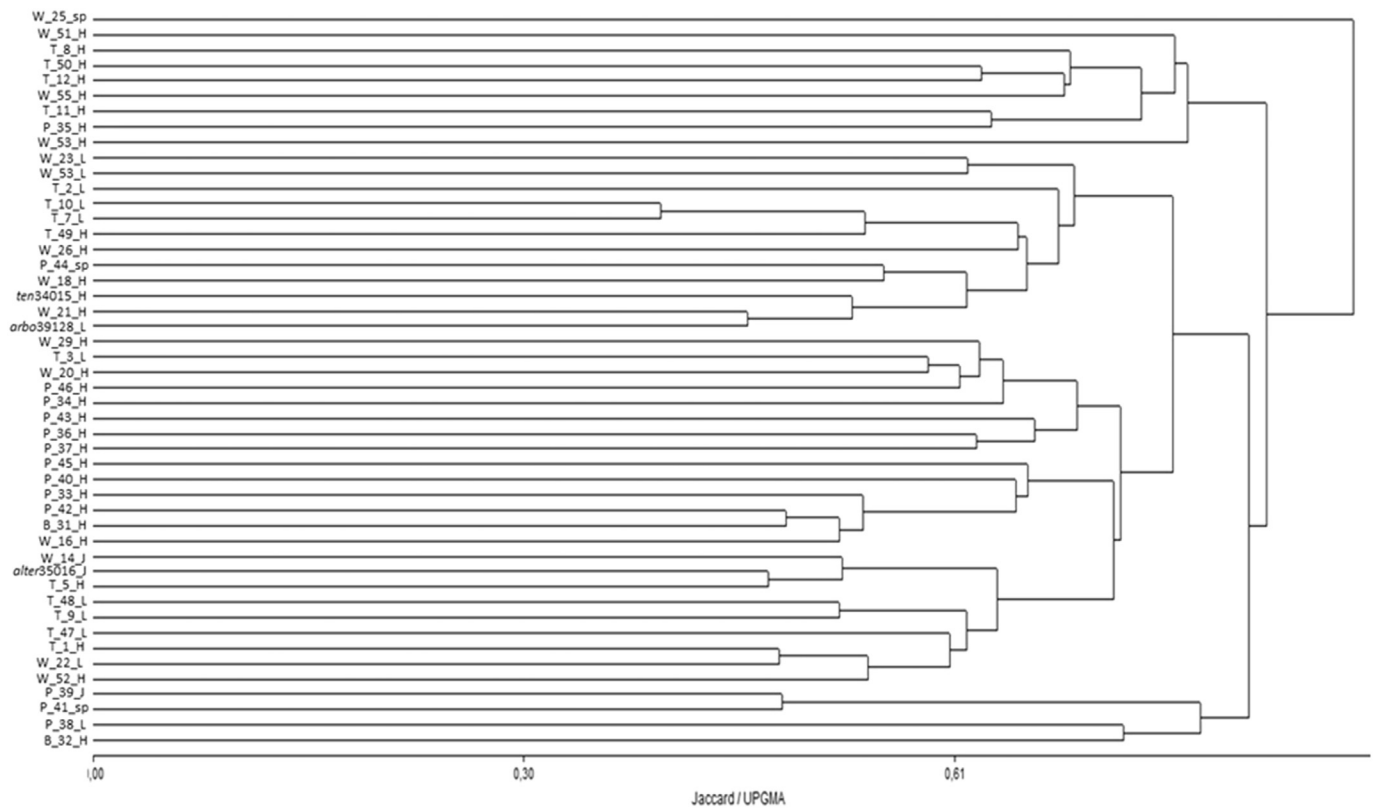

Fig. 2. Dendrogram (Jaccard/UPGMA) of the 45 Argentinean *Alternaria* isolates and the three representative *Alternaria* strains based on binary metabolite profiles. Sample codes: substrate code, strain ID, species-group ID, according to Table 1. Substrate code: B: blueberry; P: pepper; T: tomato; W: wheat. Species-group code: H: *A. tenuissima* sp.-grp.; J: *A. alternata* sp.-grp.; L: *A. arborescens* sp.-grp.; sp.: *Alternaria* sp.

network (Fig. 1). Concordantly, the seven haplotypes comprised in haplogroup HG-5 were more closely related among them than any other strain. Parsimony bootstrap values are lower than posterior probabilities (Fig. 3), something common when comparing these methods (Alfaro et al. 2003; Douady et al. 2003).

Simultaneous analysis of morphological and molecular data yielded the same topology as that obtained on the basis of the molecular dataset (Fig. 4). It is important to note the short length of the branches in the Bayesian trees.

Bayesian phylogeny obtained with *endoPG* sequences from diverse geographic regions is shown in Fig. 5. All Argentinean isolates appeared throughout clades 1 and 3 from Stewart et al. (2014) phylogeny. Haplotype denoted as “P_33_H”, which includes the *A. tenuissima*

reference strain, is more closely related to sequences from citrus clade 3 than the other isolates. As observed for Argentinean strains only, both analyses (Bayesian and maximum likelihood) resulted in the same trees topologies.

4. Discussion

Small-spored *Alternaria* taxonomy has been discussed worldwide during recent years. Despite the numerous studies on this subject, no agreement on a unique way of classification within this group currently exists. Accurate delimitation of fungal species is critical in understanding their processes of adaptation to new hosts and environments, the establishment of quarantine regulations, tests for plant resistance to

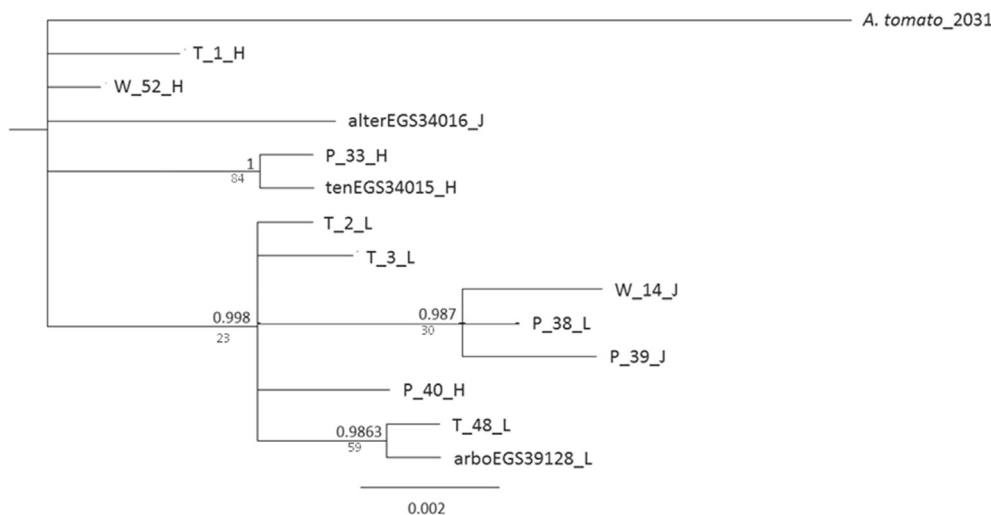

Fig. 3. Bayesian phylogeny estimated from *endoPG* sequence data of 11 haplotypes from Argentinean small-spored *Alternaria* and three reference strains. Outgroup: *A. tomato*. Numbers above branches indicate Bayesian posterior probability values and numbers below indicate bootstrap values equal or higher than 50% from the maximum parsimony tree estimation. Branch lengths indicate number of substitutions per site. Sample codes: substrate code, strain ID, species group ID, according to Table 1. Substrate code: B: blueberry; P: pepper; T: tomato; W: wheat. Species-group code: H: *A. tenuissima* sp.-grp.; J: *A. alternata* sp.-grp.; L: *A. arborescens* sp.-grp.; sp.: *Alternaria* sp.

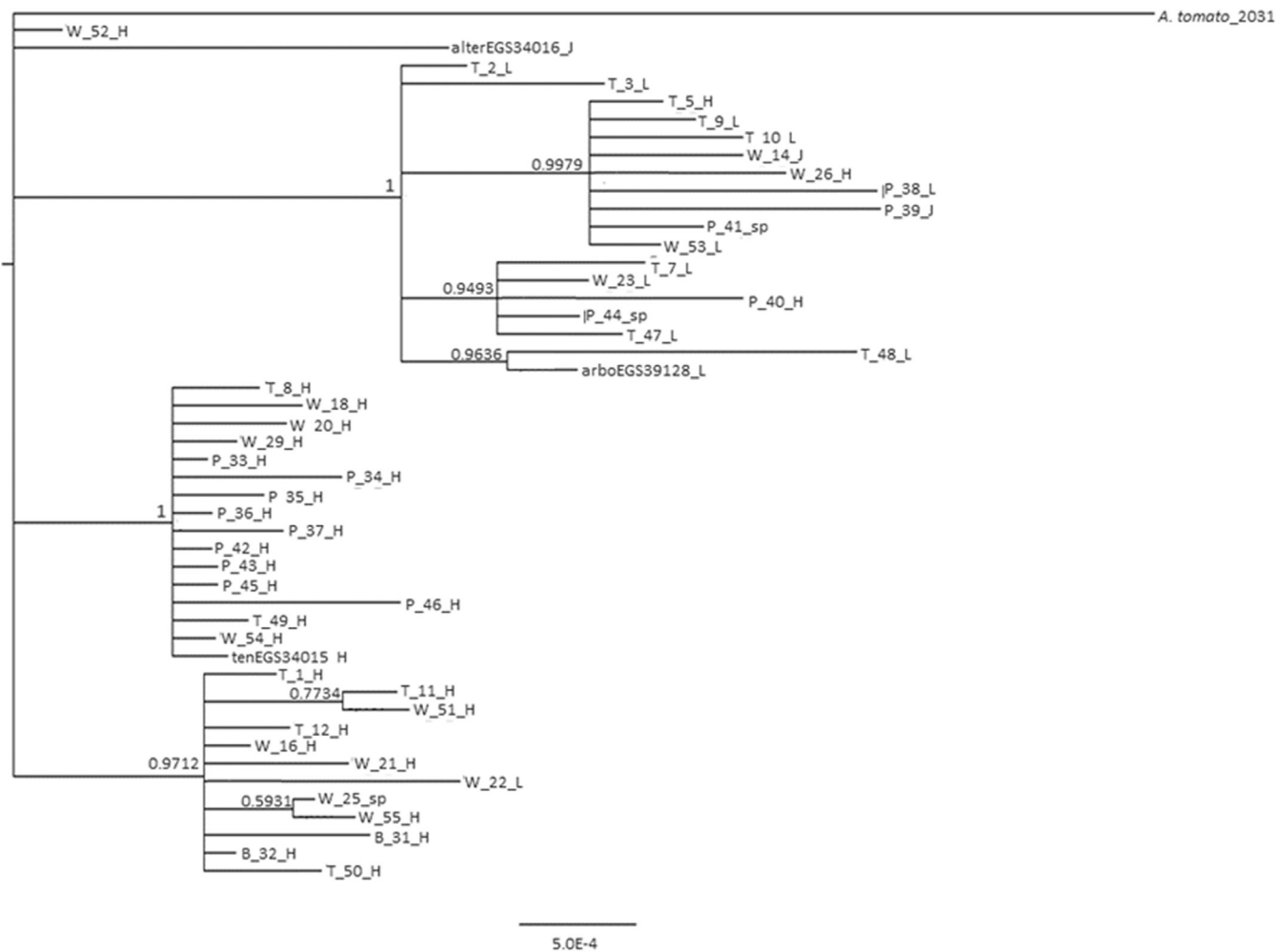

Fig. 4. Bayesian phylogeny estimated from *endoPG* sequence and morphological data of 45 Argentinean small-spored *Alternaria* and three reference strains. Outgroup: *A. tomato*. Numbers above branches indicate Bayesian posterior probability values. Branch lengths indicate number of substitutions per site. Sample codes: substrate code, strain ID, species group ID, according to Table 1. Substrate code: B: blueberry; P: pepper; T: tomato; W: wheat. Species-group code: H: *A. tenuissima* sp.-grp.; J: *A. alternata* sp.-grp.; L: *A. arborescens* sp.-grp.; sp.: *Alternaria* sp.

pathogens and to study the evolution of pathogenicity and the emergence of new infectious diseases (Harrington and Rizzo 1999; Stewart et al. 2013; Stewart et al. 2014). Misidentification of microorganisms that attack crops may lead to significant economic losses to agricultural producers, due to the inability to predict their physiological behaviour and secondary metabolite accumulation. Risk evaluation and the consequent development of prevention strategies at pre- and post-harvest stages can only be achieved through correct identification of food contaminants.

The whole set of analyses carried out in the present work supports the hypothesis that these small-spored *Alternaria* isolates from food belong to the same species. Even though morphological differences were observed, a simultaneous analysis of both morphological and molecular data yielded no clearly separated groups. Thus, it cannot be assured that the small-spored *Alternaria* have accumulated enough evolutionary change to be considered different species.

Regarding morphological observations, our results are in agreement with Andersen et al. (2002, 2015) in relation to the characteristics of isolates belonging to each sporulation group. Rotondo et al. (2012) found the same three *Alternaria* groups (H, J and L) in symptomatic tissues from apple through micro and macroscopical observation and cluster analysis of sporulation characteristics. However, their morphological descriptions cannot be compared with ours, given that growth conditions were different and it is well known that *Alternaria* features

strongly depend on them.

According to our results based only on morphological data, parsimony analysis would not allow differentiation of species, due to the low number of groups and their weak support. It seems that micro and macroscopic differences observed between isolates correspond only to phenotypic plasticity. As it has been previously stated (Andrew et al. 2009; Armitage et al. 2015; Lawrence et al. 2013), using morphological characters in *Alternaria* identification is not enough to discriminate among common small-spored species of food origin.

In addition to morphological studies, profiling of secondary metabolites (both known and unknown) has been used as a means of identification and classification (Andersen et al. 2002). Even though metabolite profiles cannot be subjected to a phylogenetic method, they provide additional data to characterize the isolates, and allow establishing relationships through similarity matrices.

The analytical method used in the present work is particularly useful for this aim since it allows the detection of a high number of metabolites simultaneously (Andersen et al. 2015; Frisvad et al. 2008). All the known compounds had been previously reported for *Alternaria* spp. (Andersen et al. 2002; Andersen et al. 2015). Pyrenochaetic acid A and Altechromone A, which were recently reported to be produced by small-spored *Alternaria* by Andersen et al. (2015), were present in most of the isolates in this work (42 and 44 out of 45 isolates, respectively). Andersen et al. (2002) reported that despite *A. arborescens* and *A.*

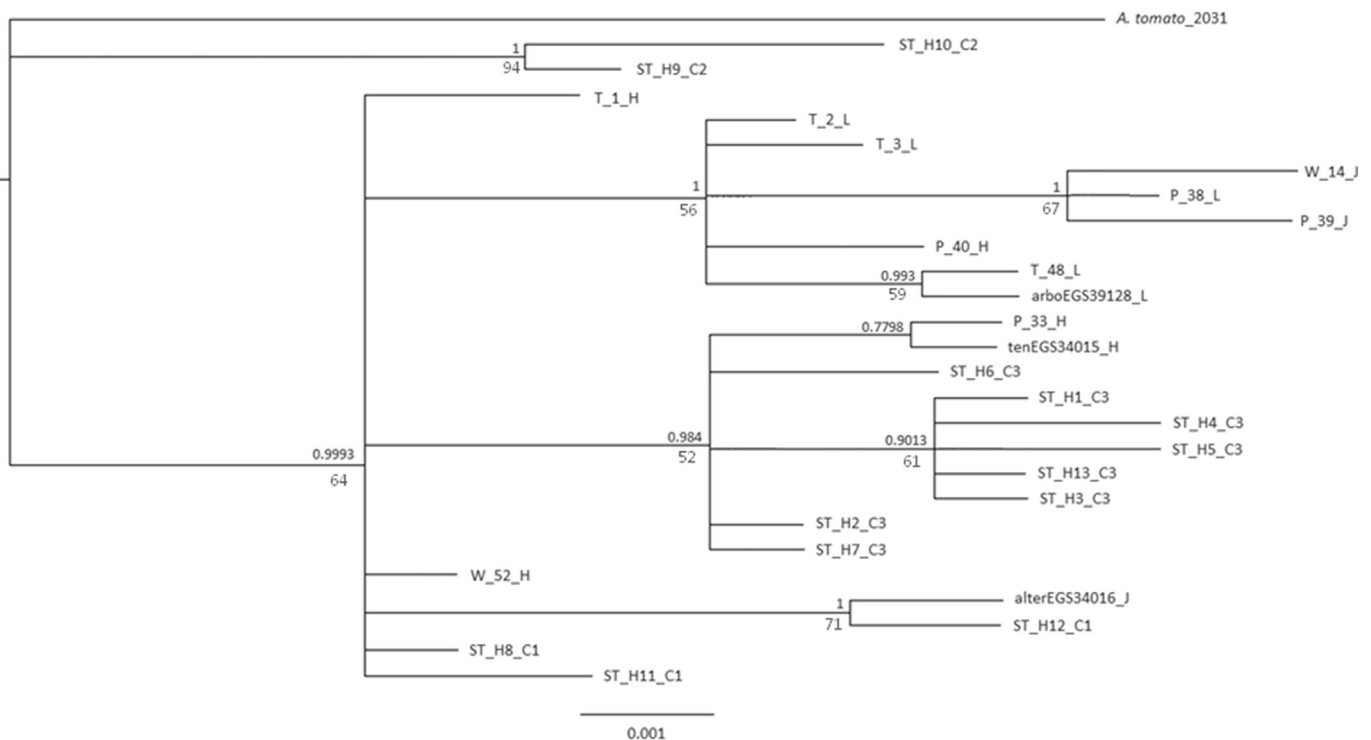

Fig. 5. Bayesian phylogeny estimated from *endoPG* sequence data of 10 haplotypes from Argentinean small-spored *Alternaria*, three reference strains and 13 sequences obtained from citrus in diverse geographic regions. Outgroup: *A. tomato*. Numbers above branches indicate Bayesian posterior probability values and numbers below indicate bootstrap values equal or higher than 50% from the maximum parsimony tree estimation. Branch lengths indicate number of substitutions per site. Sample codes: i) for Argentinean strains: substrate code_strain ID_species group ID, according to Table 1. Substrate code: B: blueberry; P: pepper; T: tomato; W: wheat. Species-group code: H: *A. tenuissima* sp.-grp.; J: *A. alternata* sp.-grp.; L: *A. arborescens* sp.-grp.; sp.: *Alternaria* sp.; ii) for citrus strains: reference work_original haplotype_original clade, according to Fig. 1A from Stewart et al. (2014).

tenuissima species-groups sharing most of the known metabolites, they also produce a number of unknown metabolites through which the two species-groups can be distinguished. However, in spite of the high number of metabolites assessed (71), it was not possible to find the same results in the Argentinean isolates. In agreement with our finding, Andersen et al. (2015) suggested that chemotaxonomic identification of small-spored *Alternaria* strains is not a useful method, with the exception of the *A. infectoria* sp.-grp., which was not studied in the present work. This is because all members within a group did not share a common metabolite profile, and due to the lack of a diagnostic compound for a particular group. Nevertheless, this assay provides valuable information about the capability of the strains to produce bioactive metabolites. As expected, a high toxigenic potential of *Alternaria* isolates from foods is reported in the present study.

Regarding phylogenetic analyses, sequencing a portion of *endoPG* gene has been previously used in small-spored *Alternaria* characterization. Even though the use of multilocus analysis is recommended given the controversy within these fungal organisms, phylogeny estimated from *endoPG* sequences was reported to be a useful tool for molecular characterization of unknown strains (Armitage et al. 2015; Hartevelde et al. 2013). Andrew et al. (2009) analysed *Alternaria* isolates from different substrates (pistachio, walnut, citrus, apple and grass), sequencing the same *endoPG* region plus two anonymous regions from their genome (using primers OPA 10-2 and OPA 1-3). They stated that one well supported clade composed predominantly of isolates classified in the *A. arborescens* sp.-grp was obtained. Isolates classified morphologically in the *A. alternata* or *A. tenuissima* groups occurred throughout each phylogeny and were not associated with any specific clade for any of the three loci. In our work, all species-groups were distributed randomly through the network including the isolates belonging morphologically to *A. arborescens* sp.-grp. In addition, Hartevelde et al. (2013) constructed a maximum likelihood phylogeny with *Alternaria* isolates from apple based on concatenated sequences of the *Alta1* and *endoPG*

genes that yielded four distinct clades. Clade 1 represented *A. arborescens* and *A. arborescens*-like isolates, clade 2 *A. tenuissima/A. mali* isolates, clade 3 *A. alternata/A. tenuissima* intermediate isolates and clade 4 *A. longipes* and *A. longipes*-like isolates. Interestingly, these authors also reported that the reference strain *A. alternata* EGS 34016 was indicated as a separate branch of the tree, as was observed also when comparing this strain with Argentinean isolates in the present work. Hereby, they concluded that high variation within the *A. alternata* sp.-grp. and a close relationship with the other species groups exist, which would also apply to the Argentinean isolates. Furthermore, Armitage et al. (2015) reported a Bayesian phylogeny for *A. alternata* sp.-grp. isolates from different hosts (such as pear, apple, citrus, strawberry) and geographic regions based on five different loci, including *endoPG*. They proposed three evolutionary lineages representing diverging subspecies *A. alternata* ssp. *arborescens*, *A. alternata* ssp. *tenuissima* and *A. alternata* ssp. *gaisen*. This study, as well as that of Andrew et al. (2009), did not support the taxonomic classification in Simmons (2007), where these organisms were considered different taxa. According to our results, this differentiation in subspecies is not evident in Argentinean isolates. Instead, the whole group would belong to a single species, which would also be in contradiction to Simmons' (2007) framework. Scarce genetic variation depicted by the haplotype network and the short branches of the Bayesian tree, as well as low bootstrap values retrieved in the parsimony analysis (Figs. 1, 2 and 3), support our conclusion. As it was previously suggested (Rotondo et al. 2012; Stewart et al. 2013; Stewart et al. 2014), it is possible that these subpopulations represent incipient species that cannot be separated reliably due to a recent divergence of these taxa, influenced by events such as incomplete lineage sorting and recombination, or that these groups are still diverging.

Given that geographic isolation is one of the processes leading to divergence into discrete lineages for asexual taxa (Fontaneto et al. 2007; Harrington and Rizzo 1999), an analysis comparing our strains

with others from different regions was carried out. Bayesian topology based on *endoPG* sequences by Stewart et al. (2014) revealed three distinct phylogenetic lineages among *A. alternata* complex obtained from citrus. According to our results, Argentinean strains belonged to a polyphyletic species described by these authors (corresponding to clades 1 and 3 from that work). Interestingly, the citrus 2 lineage remained distinct, which included one isolate also obtained from citrus in Argentina. This result indicated that no geographic isolation was detected among small-spored *Alternaria*.

Recently, several attempts of re-organization of the whole *Alternaria* genus were proposed. Lawrence et al. (2013) changed the species-groups concept by introducing the taxonomic rank of section, based on phylogenetic studies using five loci. One of them, called section “*Alternaria*”, includes *A. alternata*, *A. arborescens* and *A. tenuissima*, as well as isolates belonging to these three species groups. Woudenberg et al. (2013) also reviewed the phylogenetic relationships within the genus to obtain a robust taxonomy. They supported Lawrence et al. (2013) division in sections, including in one of them most of the small-spored species with concatenated conidia. They stated that this section comprises almost 60 *Alternaria* species based on ITS sequence data but the molecular variation within is low. More recently, Lawrence et al. (2015) described morphologically the section *Alternaria* (D.P. Lawr., Gannibal, Peever & B.M. Pryor 2013), that consists of approximately 60 species that are commonly referred in the literature as small-spored *Alternaria*. The results obtained in the present work are in agreement with these recent organizations, given the high level of resemblance observed among isolates throughout the polyphasic characterization herein performed. Even though it remains unclear if clades detected by phylogenetic analyses can be considered discrete lineages or are simply variants of the same taxa, it is evident that all small-spored *A. alternata*-like isolates are strongly related and should be considered within the same group (section level) until more evidence is gathered to match the morphological classification from Simmons (2007).

5. Conclusions

This is the first report that deeply characterizes *Alternaria* isolates from Argentinean crops through a polyphasic approach involving morphological, molecular and metabolomic analyses. Morphological differences observed among strains were not well supported under a phylogenetic species concept, meaning that their physiological behaviour prediction based only on these characters is misleading. The association of a metabolomic profile to a given morphospecies of *Alternaria* was not possible for the food isolates. Thus, identification at the species level through classical morphology or modern molecular techniques appears not to be a useful tool to predict toxicological risk in food matrices. According to the results obtained in this work and the latest organizations of the *Alternaria* genus (Lawrence et al. 2013; Lawrence et al. 2015; Woudenberg et al. 2013), it could be stated that detection of any small-spored *Alternaria* from the Section *Alternaria* (D.P. Lawr., Gannibal, Peever & B.M. Pryor 2013) in food implies a potential toxicological risk. This issue intends to give an alert to food authorities due to the high toxicological potential of this species complex, which was the most commonly isolated in all food matrixes studied in the present work as well as in many studies worldwide.

Supplementary data to this article can be found online at <http://dx.doi.org/10.1016/j.ijfoodmicro.2017.06.026>.

Acknowledgements

Financial support from Universidad de Buenos Aires (UBACYT 2014–2017 GEF, 20020130200262BA) is acknowledged. The DTU Metabolomics Platform, Department of Systems Biology, Technical University of Denmark is acknowledged for access to UHPLC-QTOF instrument.

References

- Alexander, J., Benford, D., Boobis, A., Ceccatelli, S., Cottrill, B., Cravedi, J., Di Domenico, A., Doerge, D., Dogliotti, E., Edler, L., 2011. Scientific opinion on the risks for animal and public health related to the presence of *Alternaria* toxins in feed and food. EFSA J. 9, 2407–2504.
- Alfaro, M.E., Zoller, S., Lutzoni, F., 2003. Bayes or bootstrap? A simulation study comparing the performance of Bayesian Markov chain Monte Carlo sampling and bootstrapping in assessing phylogenetic confidence. Mol. Biol. Evol. 20, 255–266.
- Andersen, B., Kröger, E., Roberts, R.G., 2002. Chemical and morphological segregation of *Alternaria arborescens*, *A. infectoria* and *A. tenuissima* species-groups. Mycol. Res. 106, 170–182.
- Andersen, B., Hansen, M.E., Smedsgaard, J., 2005. Automated and unbiased image analyses as tools in phenotypic classification of small-spored *Alternaria* spp. Phytopathology 95, 1021–1029.
- Andersen, B., Nielsen, K.F., Fernández Pinto, V., Patriarca, A., 2015. Characterization of *Alternaria* strains from Argentinean blueberry, tomato, walnut and wheat. Int. J. Food Microbiol. 196, 1–10.
- Andrew, M., Peever, T.L., Pryor, B.M., 2009. An expanded multilocus phylogeny does not resolve morphological species within the small-spored *Alternaria* species complex. Mycologia 101, 95–109.
- Armitage, A.D., Barbara, D.J., Harrison, R.J., Lane, C.R., Sreenivasaprasad, S., Woodhall, J.W., Clarkson, J.P., 2015. Discrete lineages within *Alternaria alternata* species group: identification using new highly variable loci and support from morphological characters. Fungal Biol. 119, 994–1006.
- Broggi, L.E., González, H.H.L., Resnik, S.L., Pacin, A., 2007. *Alternaria alternata* prevalence in cereal grains and soybean seeds from Entre Ríos, Argentina. Rev. Iberoam. Micol. 24, 47–51.
- Chou, H.-H., Wu, W.-S., 2002. Phylogenetic analysis of internal transcribed spacer regions of the genus *Alternaria*, and the significance of filament-beaked conidia. Mycol. Res. 106, 164–169.
- Clement, M., Posada, D., Crandall, K.A., 2000. TCS: a computer program to estimate gene genealogies. Mol. Ecol. 9, 1657–1659.
- Cota, B.B., Rosa, L.H., Caligiorno, R.B., Rabello, A.L.T., Almeida Alves, T.M., Rosa, C.A., Zani, C.L., 2008. Altenusin, a biphenyl isolated from the endophytic fungus *Alternaria* sp., inhibits trypanothione reductase from *Trypanosoma cruzi*. FEMS Microbiol. Lett. 285, 177–182.
- Darriba, D., Taboada, G.L., Doallo, R., Posada, D., 2012. jModelTest 2: more models, new heuristics and parallel computing. Nat. Methods 9, 772.
- Douady, C.J., Delsuc, F., Boucher, Y., Doolittle, W.F., Douzery, E.J.P., 2003. Comparison of Bayesian and maximum likelihood bootstrap measures of phylogenetic reliability. Mol. Biol. Evol. 20, 248–254.
- Fontaneto, D., Herniou, E.A., Boschetti, C., Caprioli, M., Melone, G., Ricci, C., Barraclough, T.G., 2007. Independently evolving species in asexual bdelloid rotifers. PLoS Biol. 5, e87.
- Frisvad, J.C., Andersen, B., Thrane, U., 2008. The use of secondary metabolite profiling in chemotaxonomy of filamentous fungi. Mycol. Res. 112, 231–240.
- Goloboff, P.A., Catalano, S.A., 2016. TNT version 1.5, including a full implementation of phylogenetic morphometrics. Cladistics 32, 221–238.
- Goloboff, P.A., Farris, J.S., Nixon, K.C., 2008. TNT, a free program for phylogenetic analysis. Cladistics 24, 774–786.
- Greco, M., Patriarca, A., Terminiello, L., Pinto, V.F., Pose, G., 2012. Toxigenic *Alternaria* species from Argentinean blueberries. Int. J. Food Microbiol. 154, 187–191.
- Hall, T.A., 1999. BioEdit: a user-friendly biological sequence alignment editor and analysis program for Windows 95/98/NT. Nucleic Acids Symp. Ser. 41, 95–98.
- Harrington, T.C., Rizzo, D.M., 1999. Defining species in the fungi. In: Worrall, J.J. (Ed.), Structure and Dynamics of Fungal Populations. Kluwer Press, Dordrecht, The Netherlands.
- Harteveld, D.O.C., Akisanmi, O.A., Drenth, A., 2013. Multiple *Alternaria* species groups are associated with leaf blotch and fruit spot diseases of apple in Australia. Plant Pathol. 62, 289–297.
- Hong, S.G., Maccaroni, M., Figuli, P.J., Pryor, B.M., Belisario, A., 2006. Polyphasic classification of *Alternaria* isolated from hazelnut and walnut fruit in Europe. Mycol. Res. 110, 1290–1300.
- Klitgaard, A., Iversen, A., Andersen, M.R., Larsen, T.O., Frisvad, J.C., Nielsen, K.F., 2014. Aggressive dereplication using UHPLC–DAD–QTOF: screening extracts for up to 3000 fungal secondary metabolites. Anal. Bioanal. Chem. 406, 1933–1943.
- Lawrence, D.P., Gannibal, P.B., Peever, T.L., Pryor, B.M., 2013. The sections of *Alternaria*: formalizing species-group concepts. Mycologia 105, 530–546.
- Lawrence, D.P., Rotondo, F., Gannibal, P.B., 2015. Biodiversity and taxonomy of the pleomorphic genus *Alternaria*. Mycol. Prog. 15.
- Logrieco, A., Moretti, A., Solfrizzo, M., 2009. *Alternaria* toxins and plant diseases: an overview of origin, occurrence and risks. World Mycotoxin J. 2, 129–140.
- Lou, J., Fu, L., Peng, Y., Zhou, L., 2013. Metabolites from *Alternaria* fungi and their bioactivities. Molecules 18, 5891–5935.
- Nemecek, G., Cudaj, J., Podlech, J., 2012. Revision of the structure and total synthesis of altenuisol. Eur. J. Org. Chem. 2012, 3863–3870.
- Nielsen, K.F., Larsen, T.O., 2015. The importance of mass spectrometric dereplication in fungal secondary metabolite analysis. Front. Microbiol. 6.
- Nylander, J.A.A., Ronquist, F., Huelsenbeck, J.P., Nieves-Aldrey, J., 2004. Bayesian phylogenetic analysis of combined data. Syst. Biol. 53, 47–67.
- Ostry, V., 2008. *Alternaria* mycotoxins: an overview of chemical characterization, producers, toxicity, analysis and occurrence in foodstuffs. World Mycotoxin J. 1, 175–188.
- Patriarca, A., Azcarate, M., Terminiello, L., Pinto, V.F., 2007. Mycotoxin production by

- Alternaria* strains isolated from Argentinean wheat. *Int. J. Food Microbiol.* 119, 219–222.
- Peever, T.L., Su, G., Carpenter-Boggs, L., Timmer, L.W., 2004. Molecular systematics of citrus-associated *Alternaria* species. *Mycologia* 96, 119–134.
- Peres, N.A.R., Agostini, J.P., Timmer, L.W., 2003. Outbreaks of *Alternaria* Brown spot of citrus in Brazil and Argentina. *Plant Dis.* 87, 750.
- Posada, D., 2008. jModelTest: phylogenetic model averaging. *Mol. Biol. Evol.* 25, 1253–1256.
- Pose, G., Ludemann, V., Segura, J., Fernández Pinto, V., 2004. Mycotoxin production by *Alternaria* strains isolated from tomatoes affected by Blackmold in Argentina. *Mycotoxin Res.* 20, 80.
- Pose, G.N., Ludemann, V., Fernandez, D., Segura, J.A., Pinto, V.F., 2010. *Alternaria* species associated with ‘moldy heart’ on peaches in Argentina. *Trop. Plant Pathol.* 35, 174–177.
- Pryor, B.M., Bigelow, D.M., 2003. Molecular characterization of *Embellisia* and *Nimbya* species and their relationship to *Alternaria*, *Ulocladium* and *Stemphylium*. *Mycologia* 95, 1141–1154.
- Pryor, B.M., Gilbertson, R.L., 2000. Molecular phylogenetic relationships amongst *Alternaria* species and related fungi based upon analysis of nuclear ITS and mt SSU rDNA sequences. *Mycol. Res.* 104, 1312–1321.
- Rambaut, A., 2006–2014. FigTree Tree Figure Drawing Tool Version. pp. v1.4.2. Available from. <http://tree.bio.ed.ac.uk/software/figtree/>.
- Rambaut, A., Suchard, M.A., Xie, D., Drummond, A.J., 2003–2013. Tracer MCMC Trace Analysis Tool Version v1.6.0. Available from. <http://beast.bio.ed.ac.uk/Tracer>.
- Robiglio, A.L., Lopez, S.E., 1995. Mycotoxin production by *Alternaria alternata* strains isolated from red delicious apples in Argentina. *Int. J. Food Microbiol.* 24, 413–417.
- Ronquist, F., Teslenko, M., van der Mark, P., Ayres, D.L., Darling, A., Höhna, S., Larget, B., Liu, L., Suchard, M.A., Huelsenbeck, J.P., 2012. MrBayes 3.2: efficient Bayesian phylogenetic inference and model choice across a large model space. *Syst. Biol.* 61, 539–542.
- Rotondo, F., Collina, M., Brunelli, A., Pryor, B.M., 2012. Comparison of *Alternaria* spp. collected in Italy from apple with *A. mali* and other AM-toxin producing strains. *Phytopathology* 102, 1130–1142.
- Samson, R.A., Houbraeken, J., Thrane, U., Frisvad, J.C., Andersen, B., 2010. Food and Indoor Fungi. CBS-KNAW Fungal Biodiversity Centre, Utrecht, The Netherlands.
- Sánchez, R., Serra, F., Tárraga, J., Medina, I., Carbonell, J., Pulido, L., de María, A., Capella-Gutiérrez, S., Huerta-Cepas, J., Gabaldón, T., Dopazo, J., Dopazo, H., 2011. Phylemon 2.0: a suite of web-tools for molecular evolution, phylogenetics, phylogenomics and hypotheses testing. *Nucleic Acids Res.* 39, W470–W474.
- Serdani, M., Kang, J.-C., Andersen, B., Crous, P.W., 2002. Characterisation of *Alternaria* species-groups associated with core rot of apples in South Africa. *Mycol. Res.* 106, 561–569.
- Simmons, E.G., 1992. *Alternaria* taxonomy: Current status, viewpoint, challenge. In: Chelkowski, J., Visconti, A. (Eds.), *Alternaria: Biology, Plant Diseases and Metabolites*. Elsevier Science Publishers, New York, pp. 1–36.
- Simmons, E.G., 2007. *Alternaria: An Identification Manual*. CBS Fungal Biodiversity Centre, Utrecht, Netherlands.
- Somma, S., Pose, G., Pardo, A., Mulè, G., Pinto, V.F., Moretti, A., Logrieco, A.F., 2011. AFLP variability, toxin production, and pathogenicity of *Alternaria* species from Argentinean tomato fruits and puree. *Int. J. Food Microbiol.* 145, 414–419.
- Stenglein, S.A., Balatti, P.A., 2006. Genetic diversity of *Phaeoisariopsis griseola* in Argentina as revealed by pathogenic and molecular markers. *Physiol. Mol. Plant Pathol.* 68, 158–167.
- Stewart, J.E., Thomas, K.A., Lawrence, C.B., Dang, H., Pryor, B.M., Timmer, L.M., Peever, T.L., 2013. Signatures of recombination in clonal lineages of the citrus brown spot pathogen, *Alternaria alternata* sensu lato. *Phytopathology* 103, 741–749.
- Stewart, J.E., Timmer, L.W., Lawrence, C.B., Pryor, B.M., Peever, T.L., 2014. Discord between morphological and phylogenetic species boundaries: incomplete lineage sorting and recombination results in fuzzy species boundaries in an asexual fungal pathogen. *BMC Evol. Biol.* 14, 38.
- Thompson, J.D., Higgins, D.G., Gibson, T.J., 1994. CLUSTAL W: improving the sensitivity of progressive multiple sequence alignment through sequence weighting, position-specific gap penalties and weight matrix choice. *Nucleic Acids Res.* 22, 4673–4680.
- Tsuge, T., Harimoto, Y., Akimitsu, K., Ohtani, K., Kodama, M., Akagi, Y., Egusa, M., Yamamoto, M., Otani, H., 2013. Host-selective toxins produced by the plant pathogenic fungus *Alternaria alternata*. *FEMS Microbiol. Rev.* 37, 44–66.
- Woudenberg, J.H.C., Groenewald, J.Z., Binder, M., Crous, P.W., 2013. *Alternaria* re-defined. *Stud. Mycol.* 75, 171–212.