

A morphological phylogeny of *Agrotis* Ochsenheimer (Lepidoptera, Noctuidae), with emphasis on the South American species

GERMÁN SAN BLAS

Submitted: 8 July 2014
Accepted: 17 October 2014
doi:10.1111/zsc.12091

San Blas G. (2014). A morphological phylogeny of *Agrotis* Ochsenheimer (Lepidoptera, Noctuidae), with emphasis on the South American species. —*Zoologica Scripta*, 00, 000–000. The monophyly of *Agrotis* Ochsenheimer in addition to the relationships among the South American species of the genus and the relationship between *Agrotis* and *Feltia* Walker are examined. A cladistic analysis was performed based on 45 terminals, with 28 ingroup and 17 outgroup taxa, and 126 characters (two continuous and 124 discrete) from adult morphology, including male and female genitalia. Parsimony analyses were performed under equal and implied weighting. Results support *Agrotis* as a monophyletic group, sister to the South American species of *Feltia* (*Feltia tent.*), and the latter being more closely related to *Agrotis* than to the ‘true’ *Feltia*. Species of *Agrotis* that branched off first (including the type species) have characters shared with both *Feltia* and *Agrotis*. South American species of *Agrotis* (with some proviso) form a clade that branched off later, with some weakly supported species groups that had been proposed in previous works. Biogeographical aspects of the group are discussed after optimizing species distributions on the tree. Trees obtained after analyses using implied weights show similar relationships to those under equal weights, particularly regarding *Feltia tent.*, showing *Feltia tent.* plus *Agrotis* forming a monophyletic group, sister to the ‘true’ *Feltia*.

Corresponding author: Germán San Blas, Laboratorio de entomología, Instituto Argentino de Investigaciones de las Zonas Áridas (IADIZA, CCT-CONICET Mendoza), Av. A. Ruiz Leal s/n, Pque. Gral. San Martín, CC: 507, CP: 5500, Mendoza, Argentina, E-mail: gsanblas@mendoza-conicet.gob.ar

Introduction

The family Noctuidae, with almost 12 000 known species, is one of the largest of the order Lepidoptera (Van Nieukerken *et al.* 2011). Recently, the classification of Noctuidae underwent several changes in the light of molecular evidence, restricting the concept of the family to the tritinae (species with hindwing vein M2 reduced or absent) noctuids (Lafontaine & Schmidt 2010, 2013; Yela & Zahiri 2011; Zahiri *et al.* 2011). Furthermore, inside Noctuidae, evidence supports grouping in a single expanded concept of the subfamily Noctuinae, the tribes formerly placed in subfamilies Noctuinae, Xyleninae and Hadeninae (Lafontaine & Schmidt 2010, 2013). Within Noctuinae, the tribe Noctuini has two subtribes: Agrotina and Noctuina (Lafontaine 2004; Fibiger & Lafontaine 2005; Lafontaine & Fibiger 2006; Lafontaine & Schmidt 2010). According to Lafontaine (2004), adults of agrotines occur mainly in xeric areas, where they often constitute the dominant group of

Lepidoptera. They comprise two main groups (previously considered as subtribes): the mainly Neotropical Austrandesina and the Agrotina, which is mainly Holarctic but represented in South America by the genera *Agrotis* Ochsenheimer and *Feltia* Walker (Lafontaine 2004).

The genus *Agrotis* includes about 300 species distributed worldwide, excepting the Poles, with 93 species described for South America (Poole 1989). The classification of the genus changed in diagnostic characters and in species composition since its description in 1816 (for a taxonomic history of the genus, see San Blas 2014). Based on systematic studies, current classifications of the species of *Agrotis* correspond to Fibiger (1990, 1993, 1997), European species; Lafontaine (2004), North American and Neotropical species; and San Blas (2014), South American species. Lafontaine (2004), based on male antennal type and genitalia, associates numerous Neotropical species formerly placed in *Agrotis* with the genus *Feltia*, within the *subterranea*-group.

San Blas (2014) revises South American species of *Agrotis*, corroborating some of the associations proposed by Lafontaine (2004) and suggesting more changes in the taxonomy of the genus. Finally, of the 93 South American nominal species formerly in *Agrotis*, only 20 remain as valid, with numerous new combinations and synonymies.

Although the genus *Agrotis* has been included in previous phylogenetic studies, these were aimed to resolve suprageneric classification (Mitchell *et al.* 1997, 2006) and only one species, *Agrotis ipsilon* (Hufnagel), was represented. The present work constitutes the first phylogenetic analysis at species level of the genus, with special attention to the South American lineages.

Materials and methods

Specimens studied

The material examined during this study was borrowed from the following institutions: CNC, Canadian National Collection of Insects, Arachnids, and Nematodes, Ottawa, Canada; IADIZA, Instituto Argentino de Investigaciones de las Zonas Áridas, Mendoza, Argentina; IMLA, Instituto y Fundación Miguel Lillo, Tucumán, Argentina; MACN, Museo Argentino de Ciencias Naturales ‘Bernardino Rivadavia’, Buenos Aires, Argentina; MLP, Museo de La Plata, Buenos Aires, Argentina; UCCC, Museo de Zoología de la Universidad de Concepción, Concepción, Chile; UNCOR, Universidad Nacional de Córdoba, Córdoba, Argentina; USNM, National Museum of Natural History, Smithsonian Institution, Washington, DC, USA; ZMUC, Statens Naturhistoriske Museum Zoologisk Museum, Copenhagen, Denmark.

Illustrations and photography

Images of adults were taken with a Panasonic LZ8 digital camera. Photographs of genitalic structures were taken under a Leica S6E stereomicroscope using a Canon PowerShot S50 digital camera, stacked using CombineZP (Hadley 2014) and enhanced with image editing software.

Taxa

Twenty-eight species of *Agrotis* from different parts of the world were included in the analysis. Eighteen species are from South America (San Blas 2014). *Agrotis acronyctoides* Angulo & Olivares and *A. caliginosa* Angulo & Olivares are known from single female specimens and were not included in the data matrix to avoid excessive missing data, because most considered characters correspond to the males. The other 10 species of *Agrotis* are representative of other regions of the world, two selected from each of the other continents, as well as the type species of the genus, and type species of some genera synonymized with *Agrotis* and of subgenera proposed. The outgroup taxa were

chosen taking into account previous studies by Lafontaine (2004) and Mitchell *et al.* (2006): two species from Australandesiina group, two species from genera close to *Agrotis*, three species of *Feltia* from North America (including type species of the genus) and plus 10 species of *Feltia tent.* from South America, according to San Blas (2014). The list of species studied, with known distribution, is presented as Appendix S1.

Characters

A total of 126 characters from adult morphology, including male and female genitalia, were scored for the terminal taxa. Two characters are continuous, and 124 are discrete multistate and treated as unordered. Ratio measurements were calculated by taking a photograph of the structure and drawing a line joining the structure mid-points, as in San Blas (2014). First selection of characters were performed following diagnostic features used in descriptions and dichotomous keys in the systematic revisions by Hampson (1903), Forbes (1933), Lafontaine (2004) and San Blas (2014). These characters were then expanded in this study, and new characters were added to account for the observed diversity (see Appendix S2 for character list and comments and Figs. 2–4 and S3 for character state images). Morphological terminology follows Lafontaine (2004).

Tree searches and cladogram construction

The data matrix of 126 characters by 45 taxa was constructed using Mesquite software (Maddison & Maddison 2014) and is provided as Appendices S4 (mesquite file matrix) and S5 (TNT file matrix). Continuous characters were standardized using the logarithm to base 10, treated as ordered and analysed as such (Goloboff *et al.* 2006). Parsimony analyses were performed with TNT 1.1 March, 2014 (Goloboff *et al.* 2008). All characters were equally weighted and most parsimonious trees were found using a traditional heuristic search on the base of Wagner trees, 2000 random addition sequences, followed by tree-bisection-reconnection (TBR) swapping algorithm, saving 20 trees per replicate and collapsing trees after the search. Branch support for resulting topologies was assessed using Bremer support (Bremer 1994), jackknifing (Lanyon 1985) and bootstrapping (Felsenstein 1985) with 500 replicates each (all implemented in a TNT script in Appendix S6). Bootstrap support was interpreted as follows (in the results and discussion): 100% = maximal clade support, 90–100% = strong support, 65–89% = moderate support, 50–64% = weak support and <50% = negligible clade support.

The program Winclada 1.00.08 (Nixon 1999) was used to map synapomorphies on the tree. When Winclada optimized two or more states of a character as possible synapo-

morphies for a clade, synapomorphies mapping in TNT was used to resolve the ambiguity when possible. The Mesquite software was used for tracing character histories.

In addition, a sensitivity analysis applying implied weighting (Goloboff 1993) was performed as a way of testing the groups obtained from equally weighted analysis. According to this weighting method, the most parsimonious trees will be those that maximize character informativeness (fit). Ten *k* values were tested (512, 256, 128, 64, 32, 16, 8, 4, 2 and 1) to down-weight homoplastic characters progressively, ensuring that the highest value produced a tree identical to the one obtained under equal weights. Finally, the strict consensus of all obtained trees was calculated (all implemented in a TNT script in Appendix S6). Thus, it can be assumed that those groups present in all trees obtained under different *k* values (homoplasy settings) either have better 'support' or the characters that support those groups are less homoplasious (more informative).

Results and discussion

Cladistic analysis under equal weights resulted in four most parsimonious trees, the strict consensus of which is shown in Fig. 1.

During the analysis, the program examined more than 394 million rearrangements, with a best score hit rate of 61 of 2000. Four trees with score of 884.064 were obtained. For discussion purposes, I use the strict consensus (Fig. 1) and focus on the most important nodes and synapomorphies. Additional information is provided in Figs S7 (most parsimonious trees obtained) and S8 (synapomorphies for each node on strict consensus tree).

The synapomorphies for each major clade are listed, and the number of characters and number of states (in superindex format) are noted between parentheses. Those synapomorphies exclusive (unique) to the group are highlighted in italics.

Monophyly of *Agrotina* group

Although testing the monophyly of the *Agrotina* group (proposed as subtribe by Lafontaine 2004) was beyond the scope of this study, the genera assigned to it were recovered as a clade (*Copablepharon* (*Euxoa* (*Feltia* (*Feltia tent.*, *Agrotis*)))) (Fig. 1). Although the support values were moderate, it is worth noting that the *Agrotina* clade is supported by as many as 27 synapomorphies (Fig. S8): male antenna biserrate (3³); *foretibia with a row of setae along both internal and external margins* (17¹); *presence of an extra (additional to the three rows present in all species) external line of spine-like setae on basal meso- and metatarsomere* (22¹); female forewing diffuse brown (27⁰); *lack of basal abdominal brushes on males* (44¹); *8th tergum sclerotized like a longitudinal rectangle with an anterior membranous oval area* (47²); male

genitalia with uncus thickened medially, in ventral view (49²) (Fig. 2C); with similar size along its length, in lateral view (50¹) (Fig. 2D); uniformly curved ventrally (51¹) (Fig. 2E); and *lacking spine-like setae on apex* (52¹); *tegumen 'shoulders' slightly marked* (57¹); *tegumen ventral margin narrow, straight* (58²); *pleural sclerite joined with tegumen dorsally, close to valve costa* (62¹); anellus sclerotized or scobinated (65¹); *anal tube with two ventrolateral sclerotized bands* (66²); *juxta hexagonal, with dorsal indentation* (67³) (Fig. 3A); and *not overlaid with valve* (69¹); valve subrectangular, gradually narrowing in dorsal half (72²) (Fig. 3B); valve corona with <16 spiniform setae (74⁰); valve 3.1–5.0 × as long as ampulla (81¹); *sacculus subtriangular, dorsal notch absent* (84²) (Fig. 3F); bulbus ejaculatorius joined dorsally and anteriorly with aedeagus (87²); *vesica with bifid median diverticulum* (100¹) (Fig. 4F); helical in shape, with close spins (107²) (Fig. 4G); and widened apically (108²); female genitalia with anal papillae 2 × as long as wide (110¹); *signa on corpus bursae absent* (120²).

The diagnostic characters of *Agrotina* previously proposed by Lafontaine (2004) were all coded in the matrix (Appendices S4 and S5), except sub-basal coil. The exclusive synapomorphy setae on foretibia (17¹) agrees with one of those diagnostic characters. The other characters proposed by Lafontaine (2004) were not recovered as synapomorphies in this tree, probably because: 1) the taxon sampling was insufficient for this purpose and 2) in the present study some characters are redefined as different characters or states related to small variations observed between species. Even so, by tracing the history of some characters on the tree, most diagnostic characters proposed by Lafontaine (2004) support the grouping of the species in an *Agrotina* clade. These characters are as follows: building frons present, in most of the species (2^{1–5}) (Fig. 2A); aedeagus with sclerotized band projected into vesica in all species except *Euxoa decora* (90^{2–4}) (Fig. 4B); cornutus on the diverticulum present, although in only four species (96¹) (Fig. 4F); and a sub-basal diverticulum present in most species and coded as left (95) (Fig. 4F) or right (97) (Fig. 4D) basal diverticula.

Previous phylogenetic studies consider only a few genera of *Agrotina*. In Mitchell *et al.*'s (1997) cladogram, *Anicla* is a sister group of *Agrotis*, but these are the only genera of the subtribe represented in that study. Lafontaine (2004) proposes a phylogeny where *Agrotis* and *Feltia* are the sister group of *Euxoa*. Mitchell *et al.* (2006) consider a larger taxon sampling, and their tree shows *Agrotis* plus *Euxoa* as sister group of *Feltia* plus *Spaelotis*. Fibiger & Lafontaine (2005) in their systematic revision suggest that *Agrotis* and *Feltia* are closer to each other than to *Euxoa*. In the cladogram obtained here (Fig. 1), *Agrotis* and *Feltia* form a clade with *Euxoa* as sister group, in agreement with Lafontaine (2004) and Fibiger & Lafontaine (2005).

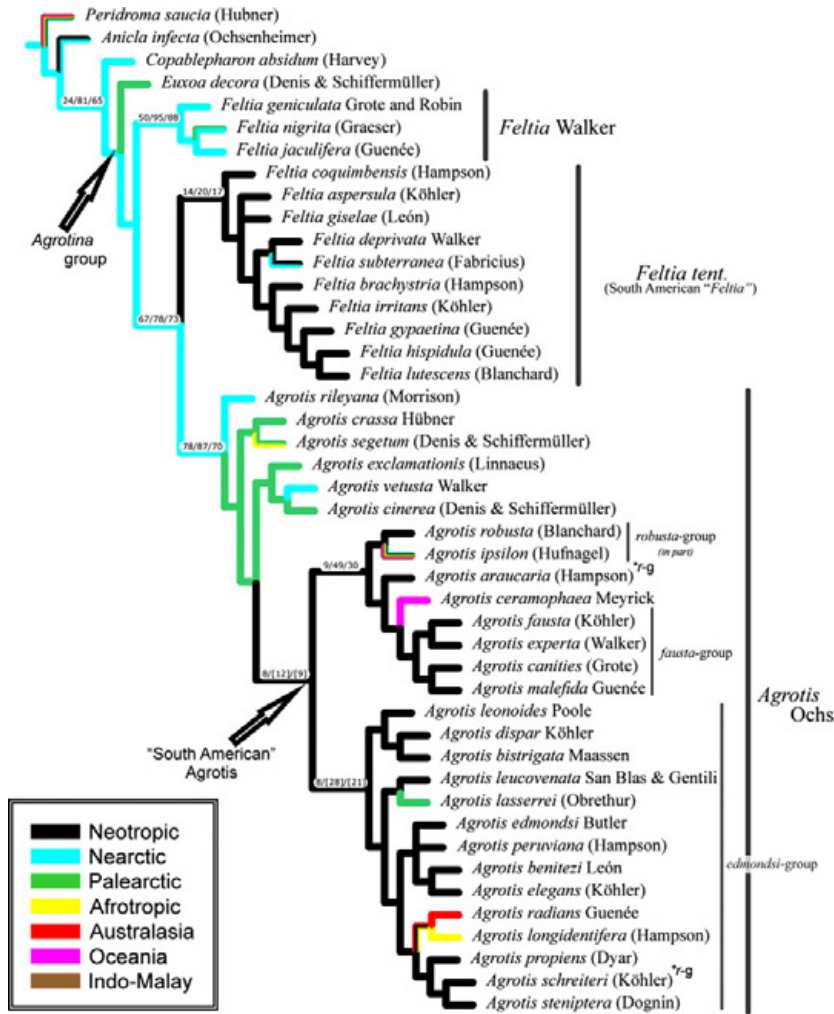

Fig. 1 Strict consensus of equally weighted character analysis (of four most parsimonious trees), with optimization of distribution for each species. Numbers above nodes indicate support values (relative Bremer/Jackknife/Bootstrap supports). r-g = *robusta*-group.

(Feltia s. str. (Feltia tent., Agrotis))

The clade comprising *Feltia s. l.* and *Agrotis* is supported by the following synapomorphies (Fig. S8): forewing basal line double (30²); antemedial line double (31²); claviform spot 2–3 × as long as wide (33²); orbicular spot rounded (34²); reniform spot kidney like (36²); male genitalia with uncus thickened in basal 1/3 and apically, in lateral view (50²) (Fig. 2D); and more or less straight, strongly curved ventrally, in apical 1/4 (51²) (Fig. 2E); tegumen ventral margin rounded (58⁴); *transtilla sclerotized as two very short subquadrate patches, basally fused to valve but apically free* (64¹) (Fig. 2F); *valve subrectangular* (72⁴) (Fig. 3B); *valve costa pouch subquadrate* (77²) (Fig. 3D).

In this tree (Figs 1 and S8), the character *transtilla* (64) (Fig. 2F) has characteristic states for each group of species: *Feltia s. str.* (64¹), *Feltia tent.* (64²) and *Agrotis* (64³). The character *valve costa pouch subquadrate* (77²) (Fig. 3D) is common to *Feltia s. l.* (excepting *Feltia aspersula*), while *costa pouch rounded* (77³) (Fig. 3D) is common to all *Ag-*

rotis. Moreover, although the presence of a claviform spot (33) is not unique, it is exclusive to the group (with some reversions) and the character *tegumen with ventral margin rounded* (58^{4,5}) is also characteristic of this group.

(Feltia s. str.)

The analysis strongly supports the monophyly of *Feltia s. str.* (Fig. 1), sustained by the following synapomorphies (Fig. S8): *patagia submarginal line dark* (10¹); *forewing orbicular spot U-shaped* (34⁴); *discal cell darker than forewing ground colour* (38¹); male genitalia with *juxta half-moon shaped* (67²) (Fig. 3A); *scobinated sclerotized area close to vesica apex present* (93¹); *vesica with left basal diverticulum subcylindrical or globose* (95²); with one *cornutus* (96¹) (Fig. 4F); and *with dorsal/posterior diverticulum present* (99¹) (Fig. 4F).

The half-moon-shaped *juxta* (67²) (Fig. 3A) is only shared by two *Feltia tent.* species. Character 95² is shared by other species of the *Agrotina* group, and the presence of

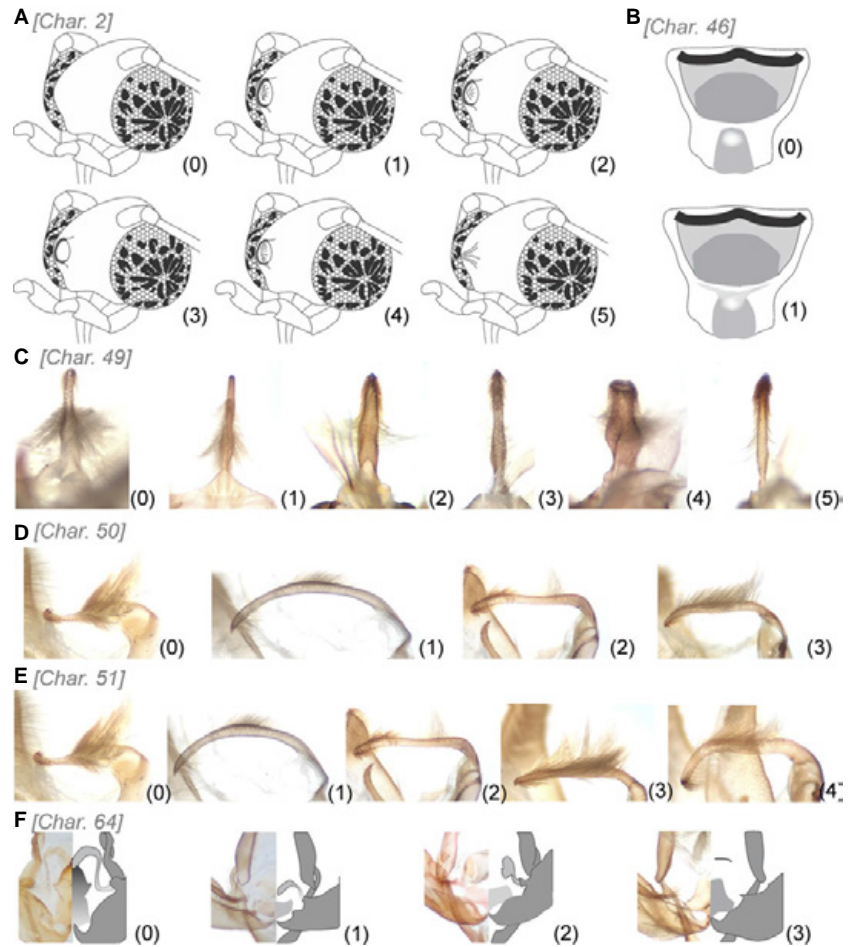

Fig. 2 (A–F) States of characters 2, 46, 49–51 and 64. (A) char. 2, frons; (B) char. 46, presence of an anterior band slightly sclerotized and projected laterally on male 8th tergum; (C) char. 49, uncus shape, ventral view; (D) char. 50, uncus shape, lateral view; (E) char. 51, uncus curvature; (F) char. 64, transtilla.

cornuti on the vesica (96¹) (Fig. 4F) is only in *Feltia irritans* (*Feltia tent.*).

Lafontaine (2004) recognizes two subgenera and six species groups inside *Feltia*. Included in the taxon sampling of this work are species from three of those species groups: *Feltia jaculifera* (*Feltia* (*Feltia*) *subgothica*-group), *F. geniculata* (*Feltia* (*Trichosilia*) *geniculate*-group) and *F. nigrita* (*Feltia* (*Trichosilia*) *mollis*-group); representative species of only the *Feltia* (*Trichosilia*) *manifesta*-group and *Feltia* (*Trichosilia*) *carthalina*-group could not be included. The three former species constitute a monophyletic group herein called *Feltia* s. str. because it contains the type species of the genus (*F. jaculifera*). The other group of species referred to by Lafontaine as *Feltia* (*Feltia*) *subterranea*-group is discussed below as '*Feltia tent.*'

(*Feltia tent.*, *Agrotis*)

The South American species of *Feltia* (named *Feltia tent.* by San Blas (2014)) and the genus *Agrotis* form a monophyletic group with moderate support values (Fig. 1), well

defined by the following synapomorphies (Fig. S8): male forewing light greyish-brown (24³); female forewing greyish brown (26⁴), hindwing iridescent, with wing margins diffuse brown (27¹); forewing orbicular spot same colour as forewing ground colour, black-edged with greyish centre (35³); pleura on 8th abdominal segment with a sclerotized ventral lunule (48²); male genitalia with uncus slightly thickened towards apex, and more or less narrowed apically, in ventral view (49⁵) (Fig. 2C); transtilla as two broad sclerotized bands, basally fused to valve but apically free (64²) (Fig. 2F); juxta transversally subrectangular with dorsal indentation and rounded lateral margins (67⁶) (Fig. 3A); aedeagal posterior projection with dorsal band wide, with posterior half slightly projected to right side (88²) (Fig. 4A); and right band subventral, seen as a more sclerotized area, sometimes as a band, slightly projected into vesica (90³) (Fig. 4B); vesica with median diverticulum absent (100⁰) (Fig. 4F); female genitalia with ostium bursae 1/3 × as wide as 8th abdominal sternite (113³); appendix bursae 1.1–3 × as long as corpus bursae (117¹).

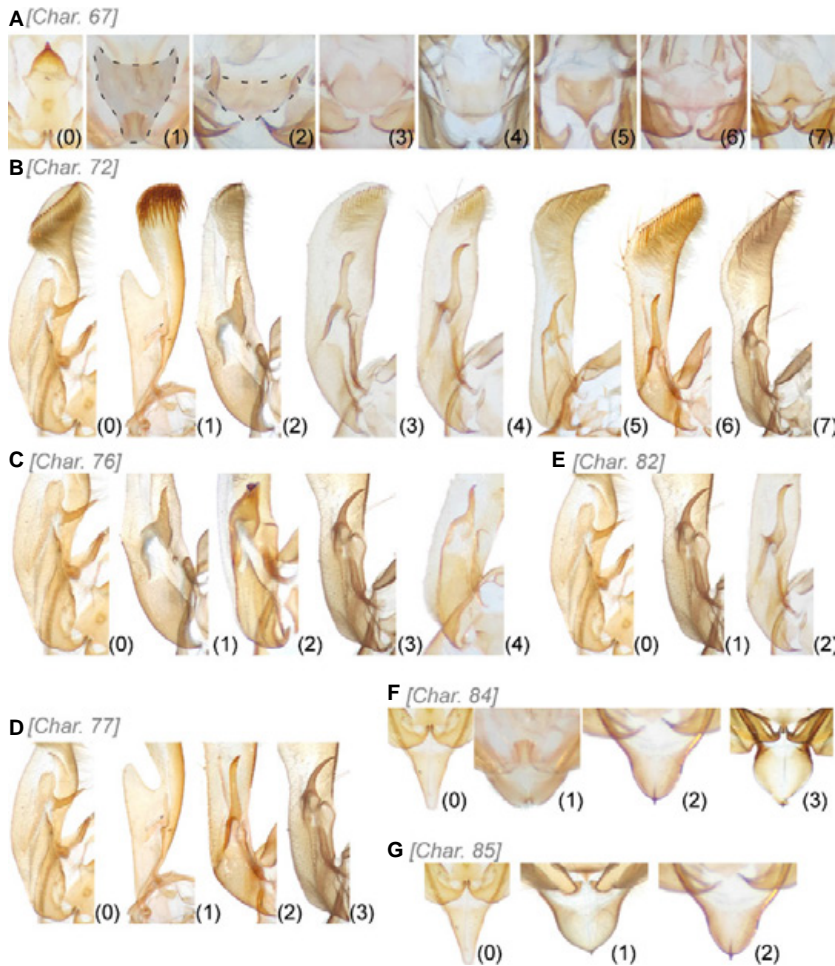

Fig. 3 (A–G) States of characters 67, 72, 76, 77, 82, 84 and 85. (A) char. 67, juxta shape; (B) char. 72, valve shape; (C) char. 76, sacculus shape; (D) char. 77, shape of valve costa pouch; (E) char. 82, ampulla swollen; (F) char. 84, saccus shape; (G) char. 85, presence of an anterior spine-like projection on saccus.

The uncus slightly thickened towards apex, and more or less narrowed apically, in ventral view (49⁵) (Fig. 2C), is exclusive to this group, with reversions in *Feltia deprivata* Walker, *Agrotis segetum* (Denis & Schiffmüller) and *A. ipsilon* (Hufnagel). Presence of an anterior spine-like projection on saccus (85) (Fig. 3G) is an exclusive character to the group, which can occur in either of two states: short blunt (85¹) and long sharpened (85²). Aedeagal posterior projection with dorsal band (88) (Fig. 4A) extended to right side (states 2, 3 and 4 represent variations) is also an exclusive character to the group, which was subdivided into those states to include observed variations. Aedeagal posterior projection with right band subventral, seen as a more sclerotized area, slightly projected into vesica (90³) (Fig. 4B) is exclusive to *Feltia tent.* excepting *F. aspersula* (Köhler). Moreover, almost all species in this group have the appendix bursae 1.1–3× as long as corpus bursae (117¹), with few reversions and many South American *Agrotis* having even larger appendix bursae.

(Feltia tent.)

This clade is supported by the following synapomorphies (Fig. S8): forewing subterminal line as light arrows blackish basally, or as small isolated blackish arrows or as a blackish single line (sometimes like arrows) distally lighter than forewing ground colour (41^{2&3&4}); tegumen ventral margin rounded, outwardly curved (58⁵); ampulla swollen postbasally (82²) (Fig. 3E).

The character aedeagal posterior projection with right band subventral, as a strongly sclerotized line, projected at least to basal 1/4 of vesica (90²) (Fig. 4B) is present in *Copablepharon*, *Feltia* s. str. and ‘basal’ species of *Feltia tent.*; while the same band but subventral, as a more sclerotized area, slightly projected into vesica (90³) (Fig. 4B), is characteristic of the remaining *Feltia tent.* Juxta transversally subrectangular with dorsal indentation and rounded lateral margins (67⁶) (Fig. 3A) is characteristic of most *Feltia tent.* and *Agrotis rileyana*. Presence of a left basal dorsal swelling (98¹) (Fig. 4E) is also characteristic of this group but shared with some *Agrotis*.

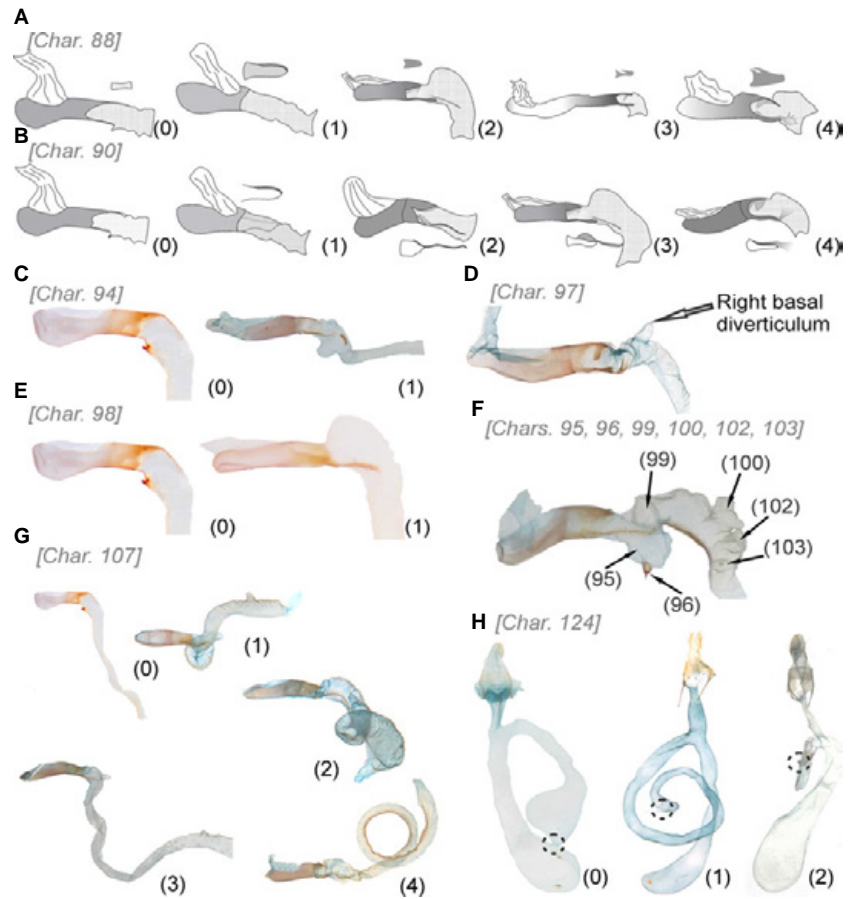

Fig. 4 (A–H) States of characters 88, 90, 94–100, 102, 103, 107 and 124. Aedeagal posterior projection: (A) char. 88, dorsal band (above detail of band in dorsal view); (B) char. 90, right band (with detail of band in dorsal view, band in grey). Vesica swellings and diverticula (C) char. 94, basal ventral swelling; (D) char. 97, right basal diverticulum; (E) char. 98, left basal dorsal swelling; (F) chars. 95, left basal diverticulum, 96, cornutus on left basal diverticulum, 99, dorsal/posterior diverticulum, 100, median diverticulum, 102, subapical diverticulum and 103, apical diverticulum; (G) char. 107, male vesica shape. Female genitalia (H) char. 124, ductus seminalis place of origin.

Noctua subterranea F. was associated with *Feltia* by McDonough and placed in the *Feltia* (*Feltia*) *subterranea*-group, together with other South American species formerly placed in *Agrotis* (many of which correspond to new combinations) by Lafontaine (2004). This group is characterized by: lacking basal spined band, longer clasper, clavus larger and more sclerotized, and male antenna doubly biserrate or doubly bifasciculate (character exclusive to *Feltia* according to Lafontaine). Lafontaine (2004) also mentions that this group shares with *Agrotis* the absence of cornuti and diverticula on vesica and a similar external resemblance, which is why many authors associate them with *Agrotis*. San Blas (2014) transfers many *Agrotis* species to *Feltia tent.* based on several shared characters, mainly male genitalia.

The strict consensus tree presented here (Fig. 1) supports the hypothesis of San Blas (2014) about *Feltia tent.* being a distinct group separated from *Feltia* s. str. and *Agrotis*. As suggested by San Blas (2014), *Feltia tent.* could be considered a distinct genus (as revalidation of *Mesembreuxoa* Hampson), but this taxonomic decision is on hold until a new analysis including more species of *Feltia tent.* and *Feltia* s. str. is undertaken. Until then, I prefer to leave it as a tentative

group because the clade has weak support values (Fig. 1), only three synapomorphies (one unique) support the group, and in the consensus tree of the implied weighting analysis (Fig. S11), *Feltia tent.* did not constitute a monophyletic group, but a polytomy together with *Agrotis* clade.

(*Agrotis*)

The genus *Agrotis*, as represented by the 28 species included in the analysis, is a monophyletic group, with moderate support values (Fig. 1), and defined by several synapomorphies (detailed in Table 1 and Fig. S8).

Lafontaine (2004) and San Blas (2014) provide numerous diagnostic characters for *Agrotis*. Several of these characters represent synapomorphies of the genus in the cladogram (Fig. 1), while some others, although useful to define *Agrotis*, show reversions higher up in the tree or define subgroups inside the genus (Table 1). In addition, there are many new synapomorphies for the genus resulting from the present analysis (Table 1). Among these, the transtilla as two short sclerotized bands, either basally or apically free (64^3) (Fig. 2F), is unique for the genus and could be considered a new diagnostic character for the clade.

Evolution of *Agrotis*

Lafontaine (2004) considers *Agrotis coquimbensis* (Hampson) (*Feltia coquimbensis* according to San Blas (2014) and present work) and *A. bistrigata* Maassen as ‘primitive’ *Agrotis*, because they lack spined band in vesica. The tree obtained

herein shows that the spined band has been lost at least two times (in *A. robusta* and in the clade formed by *A. leonoides* + *A. bistrigata* + *A. dispar*). The tree also shows that other characters shared with *Feltia* s. l. (i. e. shape of juxta and uncus of male genitalia, shape and length of vesica and

Table 1 *Agrotis* diagnostic characters proposed by recent works and synapomorphy and character history trace from strict consensus tree of equally weighted analysis. Names in bold correspond to synapomorphies exclusive (unique) to the group

Author	Diagnostic character proposed	Cladogram synapomorphies	Character trace history
Lafontaine (2004)	vesica of male genitalia with a left spiny bar near base	left basal spined band on vesica present (104 ¹)	
	basal swelling present, usually with numerous lobes		basal ventral swelling (94) (Fig. 4C) character exclusive to the genus, with some reversions
	long looping vesica in male genitalia and appendix bursae in female genitalia	vesica looping, as wide loops (107 ⁴) (Fig. 4G) vesica 4.5–8 × as long as aedeagus (92 ¹)	
	absence of median and apical diverticula		absent in all species
	apex of aedeagus hook-like shaped on right side		aedeagal posterior projection, dorsal band projected to right side (88 ^{2,3,4}) (Fig. 4A) is characteristic of SA <i>Feltia</i> + <i>Agrotis</i>
	costa margin with a marked rounded pouch close to ampulla base	costa apex thickening, rounded (costa pouch) (77 ³) (Fig. 3D)	
San Blas (2014) In addition to those proposed by Lafontaine (2004)	aedeagus with posterior half sclerotized and anterior half lightly sclerotized, almost membranous in some species, being confused with the bulbus ejaculatorius (<i>fausta</i> species group)		aedeagus posterior half sclerotized and anterior half lightly sclerotized, almost membranous (86 ¹) is characteristic of <i>fausta</i> s. l.-group
	aedeagus projected into the vesica in the following way: a dorsal strip with posterior half projected ventrolaterally through right margin, a right ventrolateral strip, and a strip close to the latter, like a band with posterior 1/3 forming a 1/4 of a spiral	aedeagal posterior projection, right band subventrally placed, as a strongly sclerotized line, slightly projected into vesica, apex Spanish fan like (90 ⁴) (Fig. 4B)	
	vesica with right basal diverticulum present, absent only in some species		right basal diverticulum (97) (Fig. 4D) exclusive to the genus, with some reversions
	vesica with postbasal, median, subapical, and apical diverticula absent		absent in all species
	vesica lacking cornuti		absent in all species
	tergum 8 sclerotized like a longitudinal rectangle, slightly narrowed anteriorly, with an anterior membranous area, and an anterior band slightly sclerotized and projected laterally.	male abdomen with an anterior band slightly sclerotized and projected laterally on tergum 8th present (46 ¹) (Fig. 2B)	
Synapomorphies resulting from strict consensus cladogram not proposed by preceding authors	male genitalia with transtilla as two short sclerotized bands, either basally or apically free (64 ³) (Fig. 2F)		
	juxta with strong ventral sclerotized projection (spine like) (68 ²)		
	sacculus medially placed, with distinct anterior and posterior margins, between 3/5 × and less wide than valve width (76 ⁴) (Fig. 3C)		
	ampulla teardrop shaped (83 ²)		
	female genitalia with corpus bursae tube shaped (118 ²)		
	ductus seminalis originated at appendix bursae apex (124 ¹) (Fig. 4H)		

length of appendix bursae and ductus seminalis origin in female genitalia) could be informative about relationships among genera and/or between species inside the genus.

Among the ‘basal’ species of the genus, *Agrotis segetum* (the type species) has characters shared with both *Agrotis* and *Feltia* s. l. It shares with the former the presence of a basal spined band (104¹); lacking diverticula (99⁰, 100⁰, 102⁰ and 103⁰) (Fig. 4F) and cornuti (96⁰ and 101⁰) (Fig. 4F) on vesica; and valve 5.1–7 × as long as ampulla (81²). On the other hand, *A. segetum* shares with *Feltia* s. l. the following characters: aedeagal posterior projection with dorsal band wide, slightly projected to right side (88²) (Fig. 4A); vesica helical in shape, with close spins (107²) (Fig. 4G); and female genitalia with appendix bursae as long as corpus bursae (117⁰). Additionally, the cladogram shows other ‘basal’ Holarctic species of *Agrotis* in a position close to *A. segetum*. According to Beck’s works (Beck 1999, 2000 and *pers. com.*), based on larval morphology, some of these species constitute different genera (*A. crassa* Hübner = *Crassagrotis*) or subgenera inside *Agrotis* (*A. exclamationis* (L.) = *Exagrotis* and *A. cinerea* (Schiffmüller) = *Scotia*). Furthermore, Beck (1999) considers *A. ipsilon* as belonging to a different South American subgenus, related to *Feltia* subgenus inside *Agrotis*. In the cladogram obtained here, those groups proposed by Beck could be considered as: 1) a series of different genera or 2) subgenera inside *Agrotis*. Until more species can be added to the analysis, as well as larval characters, I prefer a more conservative approach considering those groups as subgenera inside *Agrotis*. In my opinion, there are no characters (among the ones evaluated here) that support such division of *Agrotis* into more genera.

Within *Agrotis* clade, more ‘apical’ groups are mainly constituted by South American species (Fig. 1). San Blas (2014) proposed three groups for those South American species: *robusta*-, *fausta*- and *edmondsi*-groups (Fig. 1). According to the strict consensus obtained here (Fig. 1), the *fausta*-group (*Agrotis experta*, *A. fausta*, *A. canities* and *A. malefida*) is the only monophyletic. This clade is characterized by the synapomorphies (Fig. S8): male genitalia with 16–21 spiniform setae on valve corona (74¹); and valve 5.1–7 × as long as ampulla (81²). As mentioned by San Blas (2014), *A. ceramophaea* is closely related to this group, sharing all diagnostic characters proposed for the group (hereinafter denoted as *fausta* s. l.-group). The *robusta*-group (*A. robusta*, *A. ipsilon*, *A. araucaria* and *A. schreiteri*) is polyphyletic, with *A. schreiteri* related to *A. steniptera* and *A. araucaria* to the *fausta* s. l.-group. *Agrotis araucaria* shares some diagnostic characters with *A. robusta* and *A. ipsilon* and others with the *fausta* s. l.-group, such as longer vesica of male genitalia and appendix bursae of female genitalia. In the case of *A. schreiteri*, only external

morphological characters and male external genitalia were coded and suggest a relationship of this species with *A. steniptera*. However, once aedeagus and female genitalia can be coded, this species will most likely be related to its original species group. The clade constituted by the *robusta*-group (without *A. schreiteri*) and the *fausta* s. l.-group presents the following synapomorphies (Fig. S8): male forewing length 16.37 mm (0); female forewing length 16.67–17.18 mm (1); patagia postbasal band dark (8¹); valve subrectangular, slightly widening dorsal to ampulla (72⁷) (Fig. 3B); valve dorsal apex subrectangular, strongly projected anterodorsally (73³); valve corona with more than 21 spiniform setae (74²); and saccus subtriangular, with dorsal notch (84³) (Fig. 3F). Characters 73³ and 84³ correspond to those mentioned by San Blas (2014) as diagnostic characters shared by both species groups, and the other character mentioned (sacculus shape (76³) (Fig. 3C)) is shared by all species in the clade and *A. schreiteri*. If we consider *A. schreiteri* within the *robusta*- and the *fausta* s. l.-groups clade, all cited characters become exclusive to the group.

The third group proposed by San Blas (2014), namely *edmondsi*-group, includes the following species: *Agrotis steniptera*, *A. propriens*, *A. bistrigata*, *A. dispar*, *A. peruviana*, *A. elegans*, *A. benitezi*, *A. leonoides*, *A. edmondsi* and *A. leucovenata*. San Blas (2014) mentions many characters for this group and that although none of them individually are exclusive to the group, the combination of all of them is. According to the tree obtained here, all the characters are present in some other species of *Agrotis* or in species of other genera. Nevertheless, in the tree, species of *edmondsi*-group together with *A. lasserrei*, *A. radians* and *A. longidentifera* (Fig. 1) constitute a monophyletic group. The clade is supported by the synapomorphies (Fig. S8): male forewing length 14.49–15.07 mm (0); male antenna anterior branch equal to or <1.7 × as long as posterior branch (5⁰).

Biogeography of *Agrotis*

Only two genera of the Agrotina group are represented in South America: *Feltia* and *Agrotis* (Lafontaine 2004). Optimization of species distribution on the tree (Fig. 1) shows Nearctic and Palearctic species of Agrotina in relatively ‘basal’ position: *Copablepharon absidum*, *Euxoa decora*, *Feltia geniculata*, *F. jaculifera* and *F. nigrita*. The other species of those three genera present the same ecozone distribution (*Euxoa* with also Afrotropical species). A similar pattern is shown by genus *Agrotis*, where ‘basal’ positions are occupied by Holarctic species. The South American species included in the analysis, with some provisos, form two groups: *Feltia tent.* and South American *Agrotis*. In the *Feltia tent.* clade, *F. subterranea* occurs as far North as Southern Canada. Within *Agrotis*, in *fausta* s.l.-group plus *robusta*-group (in part) clade, *A. ceramophaea* is distributed

in Hawaii islands, *A. malefida* occurs as far North as USA, and *A. ipsilon* is distributed almost worldwide. With the exception of *A. ceramophaea*, these species are considered pests of several crops and it is likely they have Neotropical origin and have later dispersed into North America or were introduced (human-mediated) to other continents. Their Neotropical origin would be supported by the presence of shared apomorphic characters such as the male vesica length and the valve shape. Most species in *edmondsi*-group are distributed in South America, but *A. lasserrei*, *A. radians* and *A. longidentifera* present Palearctic, Australian and Afrotropic distribution, respectively.

Implied weighting analysis

The consensus tree obtained from most parsimonious trees for each *k* value is shown in Fig. S11 (trees resulting from each *k* value are presented in Figs S9 and S10). The tree (Fig. S11) shows *Agrotis* as a monophyletic group, although the species relationships are not fully resolved, except for *fausta* s. l.-group plus *A. araucaria* clade. Species of *Feltia tent.* do not form a clade, but a polytomy with *Agrotis*, and they are placed apart from *Feltia* s. str. The latter constitutes a monophyletic group sister to *Feltia tent.* plus *Agrotis* clade.

Conclusions

Species composition of *Agrotis* has changed strongly over time. These changes were related to the diagnostic characters used, mostly from external morphology, many of which have a great resemblance between species from close genera. Male genitalic characters were also proposed as diagnostic for the genus. External morphological characters as well as genitalic characters of both sexes were used here to test the monophyly of *Agrotis*, of groups proposed in recent works, and relationships with other genera. Results of this analysis bring the first phylogenetic hypothesis for the genus *Agrotis* and species from close genera, providing a more natural and predictive classification system and a basis for taxonomic decisions. The consensus tree confirmed associations of South American species suggested for *Agrotis* in previous studies. This is in agreement with San Blas (2014) who relates those species tentatively to *Feltia* (*Feltia tent.*). The species of *Agrotis* constitute a monophyletic group well supported by a set of 12 synapomorphies, mostly related to male genitalic traits. Most of these traits are cited in recent works as diagnostic for the genus and now validated after cladistic analysis based on a broad sampling of species around the world and species from close genera. Despite forming a monophyletic group, the relationships among *Agrotis* species are not clearly resolved. ‘Basal’ species of the genus constitute groups that could be considered as different genera or subgenera inside

Agrotis. The latter is the selected approach, because there is no evidence for splitting the genus into more genera. The South American species of *Agrotis* constitute the more ‘apical’ group, with some proviso. One of the three South American species groups proposed by San Blas (2014) constitutes a monophyletic group, namely the *fausta*-group, which also shows a strong relationship with the *robusta*-group. The *edmondsi*-group is paraphyletic with inclusion of species from other continents, but diagnostic characters proposed for this group were plesiomorphic, and thus, the relationships of its species with species from other parts of the world remain unsolved. The optimization of species distribution in the cladogram shows Holarctic species of *Agrotis* group and of *Agrotis* occupying ‘basal’ positions, while the South American species form two groups: *Feltia tent.* and South American *Agrotis*. The latter also includes species from other parts of the world, like Hawaii, Australasia, Afrotropic and Palearctic. Implied weighting analysis supported either monophyly of major groups or relationships between them, but relationships among species of *Agrotis* and *Feltia tent.* were mostly unresolved, shown as polytomies.

Further analyses are needed to confirm monophyly and relationships of genera and species groups. These analyses should include more representative species of *Feltia* s. str. and *Feltia tent.* to elucidate relationships of these genera with *Agrotis*. They should also include more species of *Agrotis* from other parts of the world, to better interpret character evolution and the relationships between its species and the subgenera proposed for Europe and the groups of species proposed for South America.

Acknowledgements

I am grateful to the following colleagues for allowing access to material under their care: Ole Karsholt (ZMUC, Copenhagen), Norma Diaz and Analía Lanteri (MLP, La Plata), María Virginia Colomo (IMLA, Tucumán), Arturo Roig (MACN, Buenos Aires), Andrés Angulo and Tania Olivares (UCCC, Concepción). Don Lafontaine (CNC, Canada), Michael Pogue, Don Davis and Patricia Gentili (USNM, Washington) offered guidance through the first part of this work, valuable advice and hospitality during my stay in Washington, D.C., USA and Ottawa, Canada. For their support, I thank my family, Soledad Sallenave, Celeste Amaya and Fernando Navarro†. I want to thank Adriana Marvaldi and Gustavo E. Flores for critical comments and Nelida Horak for language corrections. An anonymous reviewer and Reza Zahiri offered many comments that substantially improved the manuscript. The IADIZA (CCT-CONICET Mendoza) provided work space and equipment. This work was supported by a doctoral

fellowship from the Consejo Nacional de Investigaciones Científicas y Técnicas (CONICET). My stay in the USA was supported with a short-term fellowship (Smithsonian Institution, Washington, D.C., USA).

References

- Beck, H. (1999). Die Larven der europäischen Noctuidae - Revision der Systematik der Noctuidae (Lepidoptera: Noctuidae). *Herbipoliana*, 5(1), 864 pp.
- Beck, H. (2000). Die Larven der europäischen Noctuidae - Revision der Systematik der Noctuidae (Lepidoptera: Noctuidae). *Herbipoliana*, 5(4), 512 pp.
- Bremer, K. (1994). Branch support and tree stability. *Cladistics*, 10, 295–304.
- Felsenstein, J. (1985). Confidence limits on phylogenies: an approach using the bootstrap. *Evolution*, 39, 783–791.
- Fibiger, M. (1990). *Noctuidae Europaeae. Vol. 1: Noctuinae I*. SorØ: Entomological Press.
- Fibiger, M. (1993). *Noctuidae Europaeae. Vol. 2: Noctuinae II*. SorØ: Entomological Press.
- Fibiger, M. (1997). *Noctuidae Europaeae. Vol. 3: Noctuinae III*. SorØ: Entomological Press.
- Fibiger, M. & Lafontaine, J. D. (2005). A review of the higher classification of the Noctuoidea (Lepidoptera) with special reference to the Holarctic fauna. *Esperiana*, 11, 7–690.
- Forbes, W. T. M. (1933). A grouping of the Agrotinae genera. *Entomologica Americana*, 14, 1–38., 36 pls.
- Goloboff, P. A. (1993). Estimating character weights during tree search. *Cladistics*, 9, 83–91.
- Goloboff, P. A., Mattoni, C. I. & Quinteros, A. S. (2006). Continuous characters analyzed as such. *Cladistics*, 22, 589–601.
- Goloboff, P. A., Farris, J. & Nixon, K. (2008). TNT, a free program for phylogenetic analysis. *Cladistics*, 24, 774–786.
- Hadley, A. (2014). CombineZP. Available via <http://www.hadleyweb.pwp.blueyonder.co.uk/CZP/News.htm>.
- Hampson, G. F. (1903). *Catalogue of the Lepidoptera Phalaenae in the British Museum* Volume 4. London: Taylor and Francis.
- Lafontaine, J. D. (2004). Noctuoidea: Noctuidae (part), Noctuinae (part–Agrotini). In R. W. Hodges (Ed.) *The moths of North America, fascicle 27.1* (pp. 1–385). Washington, D.C.: Wedge Entomological Research Foundation.
- Lafontaine, J. D. & Fibiger, M. (2006). Revised higher classification of the Noctuoidea (Lepidoptera). *Canadian Entomologist*, 138, 610–635.
- Lafontaine, J. D. & Schmidt, B. C. (2010). Annotated checklist of the Noctuoidea (Insecta, Lepidoptera) of North America north of Mexico. *ZooKeys*, 40, 1–239.
- Lafontaine, J. D. & Schmidt, B. C. (2013). Comments on differences in classification of the superfamily Noctuoidea (Insecta, Lepidoptera) between Eurasia and North America. *ZooKeys*, 264, 209–217.
- Lanyon, S. (1985). Detecting internal inconsistencies in distance data. *Systematic Zoology*, 34, 397–403.
- Maddison, W. P. & Maddison, D. R. (2014). Mesquite: a modular system for evolutionary analysis. Available via <http://mesquiteproject.org/>.
- Mitchell, A., Cho, S., Regier, J. C., Mitter, C., Poole, R. W. & Matthews, M. (1997). Phylogenetic utility of elongation factor-1 alpha in Noctuoidea (Insecta: Lepidoptera): the limits of synonymous substitution. *Molecular Biology and Evolution*, 14, 381–390.
- Mitchell, A., Mitter, C. & Regier, J. C. (2006). Systematics and evolution of the cutworm moths (Lepidoptera: Noctuidae): evidence from two protein-coding nuclear genes. *Systematic Entomology*, 31, 21–46.
- Nixon, K. C. (1999). *Winclada* (BETA) ver. 1.00.08. K.C. Nixon, Ithaca, NY.
- Poole, R. W. (1989). *Lepidopterorum Catalogus (new series). Fascicle 118. Noctuidae. Part 1–3*. E. Leiden, New York, Kobenhavn, and Köln: J. Brill/Flora & Fauna Publications.
- San Blas, G. (2014). *Agrotis* Ochseneheimer (Lepidoptera, Noctuidae): a systematic analysis of South American species. *Zootaxa*, 3771, 1–64.
- Van Nieuwerkerken, E. J., Kaila, L., Kitching, I. J., Kristensen, N. P., Lees, D. C., Minet, J., Mitter, C., Mutanen, M., Regier, J. C., Simonsen, T. J., Wahlberg, N., Yen, S., Zahiri, R., Adamski, D., Baixeras, J., Bartsch, D., Bengtsson, B. Å., Brown, J. W., Bucheli, S. R., Davis, D. R., de Prins, J., de Prins, W., Epstein, M. E., Gentili-Poole, P., Gielis, C., Hättenschwiler, P., Hausmann, A., Holloway, J. D., Kallies, A., Karsholt, O., Kawahara, A. Y., Koster, J., Kozlov, M., Lafontaine, J. D., Lamas, G., Landry, J., Lee, S., Nuss, M., Park, K., Penz, C., Rota, J., Schintlmeister, A., Schmidt, B. C., Sohn, J., Solis, M. A., Tarmann, G. M., Warren, A. D., Weller, S., Yakovlev, R. V., Zolotuhin, V. V. & Zwick, A. (2011). Order Lepidoptera Linnaeus, 1758. In Zhang, Z.Q. (ed), *Animal biodiversity: An outline of higher-level classification and survey of taxonomic richness*. *Zootaxa*, 3148, 212–221.
- Yela, J. L. & Zahiri, R. (2011). Phylogenetic overview of Noctuidae *sensu lato*. Noctuidae Europaeae, Volume 13 Lymantriinae and Arctiinae, including phylogeny and checklist of the quadrifid Noctuoidea of Europe (ed. by Witt, T.J. & Ronkay, L.). Svendborg, Denmark: SvendborgTryk.
- Zahiri, R., Kitching, I. J., Lafontaine, J. D., Mutanen, M., Kaila, L., Holloway, J. D. & Wahlberg, N. (2011). A new molecular phylogeny offers hope for a stable family-level classification of the Noctuoidea (Lepidoptera). *Zoologica Scripta*, 40, 158–173.

Supporting Information

Additional Supporting Information may be found in the online version of this article:

Appendix S1. List of species studied, with known distribution.

Appendix S2. List of characters used, with comments on their use in previous works.

Fig. S3. States of characters 45, 54, 56, 59, 89, 121 and 122.

Appendix S4. Matrix in the Mesquite format file (without continuous characters).

Appendix S5. Matrix in the TNT format file (continuous characters included).

Appendix S6. TNT script file (including commands for equally weighted character analysis, implied weighting analyses and branch support estimate).

Fig. S7. Equally weighted character analysis cladograms.

Fig. S8. Strict consensus of equally weighted character analysis showing synapomorphies for each node.

Fig. S9. Implied weighted character analysis cladograms ($k = 1-32$).

Fig. S10. Implied weighted character analysis cladograms ($k = 64-512$).

Fig. S11. Strict consensus of trees obtained under implied weighting analyses with different k values (1, 2, 4, 8, 16, 32, 64, 128, 256 and 512).

Supporting Information S1. List of species studied, with known distribution.

Ingroup taxa.

Genus *Agrotis*, South American species. *Agrotis araucaria* (Hampson), southern part of Argentina and Chile; *A. benitezi* León, Chile; *A. bistrigata* Maassen, Ecuador; *A. canities* (Grote), central and northern Argentina; *A. dispar* Köhler, Bolivia; *A. edmondsi* Butler, Argentinean and Chilean Patagonia; *A. elegans* (Köhler), Argentinean Patagonia; *A. experta* (Walker), Peru, Ecuador, and northern Chile; *A. fausta* (Köhler), central-eastern Argentina; *A. ipsilon* (Hufnagel), worldwide; *A. leonoides* Poole, Argentinean Patagonia; *A. leucovenata* San Blas & Gentili, central-western Argentina; *A. malefida* Guenée, American continent; *A. peruviana* (Hampson), northern Argentina, Bolivia, Peru, and Colombia; *A. propriens* (Dyar), southern Peru; *A. robusta* (Blanchard), Paraguay, Brazil, Bolivia, Chile and Argentina; *A. schreiteri* (Köhler), north-western Argentina; *A. steniptera* (Dognin), southern Peru.

Genus *Agrotis*, species of other regions of the world. *Agrotis ceramophaea* Meyrick, Hawaii; *A. cinerea* (Schifferrmüller), Europe and central Asia (Type species of genus *Scotia* Hübner, synonymy of *Agrotis*); *A. crassa* Hübner, North Africa and south-western Asia (Type species of genus *Crassagrotis* Beck, synonymy of *Agrotis*); *A. exclamationis* (Linnaeus), Asia (Type species of genus *Noctua* Boisduval, synonymy of *Agrotis*, and type species of subgenus *Agrotis* (*Exagrotis*) Beck); *A. lasserrei* (Oberthür), Africa (Type species of genus *Powellinia* Oberthür, synonymy of *Agrotis*); *A. longidentifera* (Hampson), Africa; *A. radians* Guenée, Australia; *A. rileyana* (Morrison), North America (Type species of genus *Onychagrotis* Hampson, synonymy of *Agrotis*); *A. segetum* (Denis & Schifferrmüller), Europe (Type species of genus *Agrotis*); *A. vetusta* Walker, North America.

Outgroup taxa.

Austrandesina group. *Anicla infecta* (Ochsenheimer), American continent; *Peridroma saucia* (Hübner), worldwide.

Agrotina group. Close genera. *Copablepharon absidum* (Harvey), North America; *Euxoa decora* (Denis & Schifferrmüller), Asia (Type species of genus *Euxoa* Hübner).

Feltia Walker s. str. *Feltia geniculata* Grote & Robinson, North America; *F. jaculifera* (Guenée) (= *F. ducens* Walker), North America (Type species of *Feltia*); *F. nigrita* (Graeser), North America.

Feltia tent. *Feltia aspersula* (Köhler), north-western Argentina; *F. brachystria* (Hampson), southern Brazil, Uruguay, and central-eastern Argentina; *F. coquimbensis* (Hampson), central Chile; *F. deprivata* Walker, Ecuador, Peru, Argentina, and Chile; *F. giselae* (León), central-western Chile; *F. gypaetina* (Guenée), central and central-eastern Argentina; *F. hispidula* (Guenée), Peru and Ecuador; *F. irritans* (Köhler), Argentina; *F. lutescens* (Blanchard), central and southern Argentina and Chile; *F. subterranea* (Fabricius), American continent and Europe.

Supporting Information S2. List of characters, with comments on their use on previous works.

Selection of characters follow: Hampson (1903), Forbes (1933), Lafontaine (2004), and San Blas (2014) (below referred to by their author names), expanded subsequently in this paper.

Many of the color pattern characters (with some changes and additions) are used by all authors to group species within genera, characterize genera, and, in some cases, to relate genera within tribes as well.

Continuous characters

0. Male forewing length.
1. Female forewing length.

Discrete characters

Head

2. Frons (Fig. 2A): (0) smooth; (1) central projection, with raised edge of rough surface and elevated wrinkled central plate; (2) central projection, with raised edge of rough surface and projected anteriorly into a point; (3) central projection with raised edge of rough surface, not projected anteriorly into a point; (4) central projection, with raised edge of rough surface and projected anteriorly like a vertical line; (5) central pointed projection, without raised edge.

Hampson uses frons “prominences” as main character to separate genera within “Agrotinae” and Forbes to separate groups and characterize some species. Also, Lafontaine uses this character to separate some genera on his keys.

3. Male antenna form: (0) filiform; (1) beadlike; (2) serrate; (3) biserrate; (4) bipectinate; (5) doubly biserrate.

Hampson uses type of antennae to separate “sections” within many genera (e.g., *Porosagrotis*, *Euxoa*, and *Agrotis*). This is also used by Forbes to group South American species of *Agrotis* and by Lafontaine to separate species groups within *Feltia* and other

genera. San Blas also characterize the genus *Feltia* and separate species within *Agrotis* using the shape of male antenna.

4. Male antenna fascicles: (0) absent; (1) bifasciculate; (2) doubly bifasciculate.

A feature that Lafontaine and San Blas mention as a diagnostic character between *Feltia* and *Agrotis* is the presence of doubly bifasciculate antennae in the former and of bifasciculate antennae in *Agrotis*.

5. Anterior branch length / posterior branch length ratio on male antenna: (0) equal or less than 1.70; (1) more than 1.70.

Thorax

6. Patagia color: (0) same color as thorax; (1) darker than thorax; (2) lighter than thorax.
7. Patagia basal line: (0) undifferentiated; (1) dark; (2) clear.
8. Patagia postbasal band: (0) undifferentiated; (1) dark; (2) clear.
9. Patagia medial line: (0) undifferentiated; (1) dark; (2) clear; (3) wide, as a collar.
10. Patagia submarginal line: (0) undifferentiated; (1) dark; (2) clear.
11. Patagia terminal line: (0) undifferentiated; (1) dark; (2) clear.
12. Tegula color related to patagia: (0) same color; (1) darker; (2) lighter.
13. Tegula basal line: (0) undifferentiated; (1) dark; (2) clear.
14. Tegula marginal line: (0) undifferentiated; (1) dark; (2) clear.
15. Tegula marginal line width: (0) uniform width; (1) widened anteriorly.
16. Foretibia / foretarsus first segment length ratio: (0) less than 1.31; (1) equal or more than 1.31.
17. Setae on margins of foretibia: (0) a row of setae along internal margin and one or two setae on apex of external margin only; (1) a row of setae along both sides.

Hampson uses this character (with many more states) in his key to separate genera within “*Agrotinae*.” Lafontaine mentions that species of the subtribe *Austrandesina* have a partial

row of setae on outer margin of foretibia and those of the subtribe Agrotina a full row of setae on both sides.

18. Presence of an extra (additional to the three rows present in all species) external line of spine-like setae on foretarsus first segment: (0) absent; (1) present.
19. Presence of an extra internal line of spine-like setae on foretarsus first segment: (0) absent; (1) present.
20. Presence of an extra (additional to the three rows present in all species) external line of spine-like setae on foretarsus second segment: (0) absent; (1) present.
21. Presence of an extra internal line of spine-like setae on foretarsus second segment: (0) absent; (1) present.
22. Presence of an extra (additional to the three rows present in all species) external line of spine-like setae on basal meso- and metatarsomere: (0) absent; (1) present.
23. Presence of an extra (additional to the three rows present in all species) external line of spine-like setae on second meso- and metatarsomere: (0) absent; (1) present.

Wings

24. Male forewing ground color: (0) dark greyish brown; (1) whitish grey; (2) yellow; (3) light greyish brown; (4) greyish brown; (5) greyish; (6) brownish grey.
25. Male hindwing ground color: (0) diffuse brown; (1) iridescent, wing margins diffuse brown; (2) iridescent.
26. Female forewing ground color: (0) dark greyish brown; (1) whitish grey; (2) yellow; (3) light greyish brown; (4) greyish brown; (5) greyish; (6) brownish grey; (7) ocher greyish brown.
27. Female hindwing ground color: (0) diffuse brown; (1) iridescent, wing margins diffuse brown; (2) iridescent.
28. Forewing subcostal band color: (0) undifferentiated; (1) lighter than forewing ground color; (2) darker than forewing ground color.
29. Forewing basal dash color: (0) undifferentiated; (1) darker than forewing ground color.
30. Basal line color: (0) undifferentiated; (1) single, light brown basally; (2) double.

31. Antemedial line color: (0) undifferentiated; (1) single, light brown basally; (2) double.
32. Length of antemedial line posterior projection (tooth): (0) line not projected; (1) 1–2 × as wide as long; (2) 3–4 × as wide as long.
33. Claviform spot shape: (0) undifferentiated; (1) 4–5 × as long as wide; (2) 2–3 × as long as wide; (3) as long as wide.
34. Orbicular spot shape: (0) undifferentiated; (1) diffuse; (2) rounded; (3) oval; (4) u-shaped; (5) oblique.
35. Orbicular spot color: (0) diffuse greyish spot; (1) spot lighter than forewing ground color; (2) same color as forewing ground color, only differentiable by black marginal line; (3) same color as forewing ground color, black-edged with greyish center.
36. Reniform spot shape: (0) undifferentiated; (1) diffuse; (2) Kidney-like; (3) open on anterior and posterior margins.
37. Reniform spot color: (0) diffuse greyish spot; (1) as forewing ground color, black-edged with greyish center; (2) same color as forewing ground color, only differentiable by black marginal line.
38. Discal cell color: (0) same color as forewing ground color; (1) darker than forewing ground color; (2) same color as forewing ground color, with a black streak of variable width joining both spots.
39. Postmedial line color: (0) undifferentiated; (1) as isolated dots; (2) double, sometime single but strongly curved between veins; (3) single (diffuse on some specimens), light brown distally; (4) as small clear arrows; (5) single, lighter than forewing ground color.
40. Posterior half projections on postmedial line: (0) projections absent; (1) serrated, projections as long as wide; (2) deeply serrated, projections longer than wide.

Used by Hampson to differentiate species. San Blas mentions that despite this character is not diagnostic, it is useful to associate some species to *Feltia tent*.

41. Subterminal line color: (0) undifferentiated; (1) single, lighter than forewing ground color; (2) as light arrows, blackish basally; (3) as small isolated blackish arrows; (4) blackish single line (sometimes like arrows) distally lighter than forewing ground color.

42. Streaks projecting from reniform spot external margin to subterminal line: (0) undifferentiated; (1) between M1-M2 veins; (2) between M1-M2-M3 veins.
43. Streaks projecting basally from subterminal line: (0) undifferentiated; (1) between M1-M2-M3 veins; (2) between M2-M3 veins.

Male abdomen

44. Abdominal brushes: (0) present; (1) absent.
45. Tergum 8th sclerotization pattern (Fig. S3A): (0) longitudinally subrectangular, wide posteriorly and gradually narrowed on anterior half; (1) transversally subrectangular, 1/3 × as long as tergum, posteriorly located; (2) longitudinally subrectangular, not narrowed in any part.
46. Anterior band slightly sclerotized and projected laterally on tergum 8th (Fig. 2B): (0) absent; (1) present.

According to San Blas, the presence of this projection is a diagnostic character for the genus *Agrotis*.

47. Sternum 8th sclerotization pattern: (0) as a posterior diffuse band; (1) diffuse all over sternum; (2) subrectangular with oval anterior membranous area.
48. Pleura on 8th segment sclerotization pattern: (0) undifferentiated; (1) diffuse on posterior margin; (2) ventral lunule; (3) central lunule.

Male genitalia

49. Uncus shape, ventral view (Fig. 2C): (0) cylindrical; (1) narrow on basal 2/3; (2) thickened medially; (3) thickened submedial and subapically; (4) thickened medial and apically; (5) slightly thickened toward apex, and more or less narrowed on apex.
50. Uncus shape, lateral view (Fig. 2D): (0) strongly narrowed apically; (1) similar size all along; (2) thickened on basal 1/3 and apically; (3) thickened medially.

51. Uncus curvature (Fig. 2E): (0) strongly upturned apically; (1) uniformly curved ventrally; (2) more or less straight, strongly curved ventrally on apical 1/4; (3) more or less straight; (4) sinuous, strongly curved ventrally on apical 1/4.

Lafontaine mentions that variations in uncus are diagnostic for different subgenera within *Feltia*. Here I separate “uncus shape” into three characters (49–51) trying to codify those variations mentioned by Lafontaine and additional variations seen.

52. Presence of spine-like setae on uncus apex: (0) two dorsal spines; (1) absent; (2) numerous dorsal subapical spines; (3) ventral spines.

Lafontaine mentions that it is frequent for *Austrandesiiina* species to have setae on uncus apex.

53. Width of ventral hair-like seta on uncus: (0) shorter and wider towards apex; (1) all setae same width.

54. Strong hair-like setae on dorso-apical 1/4 of uncus (Fig. S3B): (0) absent; (1) present.

55. Uncus apex shape: (0) rounded; (1) sharpened, spine like.

56. Uncus-Tegumen junction (Fig. S3C): (0) narrow, as wide as uncus; (1) medium, 2 × as wide as uncus; (2) wide, 3 × as wide as uncus.

57. Tegumen "shoulders": (0) undifferentiated; (1) slightly marked; (2) strongly marked.

58. Tegumen ventral margin shape: (0) undilated, inwardly curved; (1) slightly dilated, inwardly curved; (2) narrowed, straight; (3) slightly dilated, rounded; (4) rounded; (5) rounded, outwardly curved.

59. Presence of a tegumen ventral projection towards pleural sclerite (Fig. S3D): (0) absent; (1) faint external projection, joining pleural sclerite; (2) faint ventral projection, joining pleural sclerite; (3) strong external projection, joining pleural sclerite; (4) faint external projection, not joining pleural sclerite.

60. Internal projection of tegumen anterior margin: (0) present; (1) absent.

61. Posterior projection of tegumen posterior margin: (0) ventral 1/3 projected; (1) not projected; (2) medially projected.

62. Pleural sclerite-tegumen joint: (0) dorsal, far from valve; (1) dorsal, close to valve.
63. Tegumen-vinculum joint: (0) pleural sclerite fused with vinculum, with dorsal half fused with tegumen ventral 1/3; (1) pleural sclerite long and thin, fused with vinculum and inwardly curved dorsally where it joins tegumen; (2) pleural sclerite long and thin, T-shaped, fused with vinculum and inwardly curved dorsally where it joins tegumen.
64. Transtilla (Fig. 2F): (0) two thin sclerotized bands, basally fused to valve but apically free; (1) two very short subquadrate patches, basally fused to valve but apically free; (2) two broad sclerotized bands, basally fused to valve but apically free; (3) two short sclerotized bands, either basally or apically free; (4) undifferentiated.
65. Anellus: (0) membranous; (1) sclerotized, scobinated; (2) scobinated.
66. Anal tube sclerotization pattern: (0) fully sclerotized ventrally; (1) two ventro-lateral bands and two dorso-lateral long bands joining tegumen; (2) two ventro-lateral bands.
67. Juxta shape (Fig. 3A): (0) subtriangular, dorsal margin rounded with a heavily sclerotized spine; (1) subtriangular, pointing ventrally with two dorso-lateral projections; (2) half-moon shaped; (3) hexagonal with dorsal indent; (4) longitudinally subrectangular, rounded borders with latero-dorsal projections; (5) subrectangular without dorsal indent; (6) transversally subrectangular with dorsal indentation and rounded lateral margins; (7) subrectangular, ventral 1/3 of lateral margin subquadrate projected.
68. Juxta ventral projection: (0) small projection; (1) marked projection; (2) marked sclerotized projection (spine like).
69. Juxta-valve relation: (0) juxta overlaid with valve ventral edge; (1) juxta not overlaid with valve.
70. Clavus shape: (0) undifferentiated area with hair-like scales; (1) subquadrate, as long as wide; (2) cylindrical, short, 2 × as long as wide; (3) cylindrical, between 2–4 × as long as wide; (4) cylindrical, long, more than 4 × as long as wide.

Lafontaine mentions that *Feltia* species have a larger and more heavily sclerotized clavus than *Agrotis*.

71. Clavus apex: (0) uniform width; (1) broaden apically.

72. Valve shape (Fig. 3B): (0) subrectangular, posteriorly convex below clasper and anteriorly convex after clasper, with subapical narrowing; (1) broad on ventral half, with a strong medial indent and narrow after indent; (2) subrectangular, gradually narrowing on dorsal half; (3) subrectangular, strongly widened on costa apex; (4) subrectangular; (5) subrectangular, curved, elongated, and very narrow; (6) subrectangular, gradually widened on dorsal half; (7) subrectangular, slightly widened dorsal to ampulla.
73. Valve dorsal apex shape: (0) rounded; (1) subrectangular, not projected; (2) subrectangular, slightly projected antero-dorsally; (3) subrectangular, strongly projected antero-dorsally.

Lafontaine suggests that this character separates subgenera within *Feltia* and San Blas uses it to group species within *Agrotis*.

74. Number of spiniform setae on valve corona: (0) less than 16; (1) between 16 and 21; (2) more than 21.
75. Valve corona length / valve maximum width ratio: (0) less or equal to 0.90; (1) between 0.91 and 1.0; (2) more than 1.0.
76. Sacculus shape (Fig. 3C): (0) anterior margin differentiated, posterior margin undifferentiated and dorsally limited by clasper plate; (1) distinct, $1/2 \times$ as wide as valve, projected posteriorly between clasper plate and valve posterior margin; (2) posteriorly placed, $1/2 \times$ as wide as valve, projected posteriorly beyond clasper base; (3) medially placed, with distinct anterior and posterior margins, $3/5 \times$ as wide as valve; (4) medially placed, with distinct anterior and posterior margins, between $3/5 \times$ and less wide than valve.
77. Shape of valve costa pouch (Fig. 3D): (0) undifferentiated; (1) as a rounded costa internal projection; (2) costa apex thickening, subquadrate; (3) costa apex thickening, rounded.

Lafontaine proposes a well-differentiated pouch on costal margin of valve as a diagnostic character for the genus. This pouch it is also present in other species, but differently shaped according to Lafontaine.

78. Presence of digitus: (0) present; (1) small crease; (2) absent.
79. Presence of editum: (0) absent; (1) small crease; (2) cylindrical short.
80. Presence of clasper proper: (0) present; (1) restricted to clasper plate.
81. Valve / ampulla length ratio: (0) equal or less than 3.0; (1) between 3.1 and 5.0; (2) between 5.1 and 7.0; (3) more than 7.0.

According to Lafontaine, *Agrotis* presents ampulla about 1/4 length of the valve and *Feltia* 1/3 of valve length. A longer ampulla in *Feltia* than in *Agrotis* is also mentioned by San Blas.

82. Presence of ampulla swollen (Fig. 3E): (0) not swelled; (1) basal; (2) postbasal.

San Blas proposes a postbasal swelled ampulla as diagnostic for South American species of *Feltia* (*Feltia tent.*).

83. Ampulla shape: (0) rise from internal margin of clasper plate, strongly upturned basally; (1) inwardly curved; (2) teardrop shaped.

Lafontaine and San Blas mention that in most *Agrotis* the base of the ampulla is teardrop shaped.

84. Saccus shape (Fig. 3F): (0) subtriangular, ventral apex sharpened; (1) semicircular, slightly differentiable; (2) subtriangular, dorsal notch absent; (3) subtriangular, with dorsal notch.

The presence of a dorsal notch is useful to separate South American species groups, according to San Blas.

85. Presence of an anterior spine-like projection on saccus (Fig. 3G): (0) absent; (1) short blunt projection; (2) long sharpened projection.

Aedeagus

86. Aedeagus sclerotization pattern: (0) fully sclerotized; (1) posterior half sclerotized and anterior half lightly sclerotized, almost membranous.

According to San Blas, the *fausta*-group within *Agrotis* is characterized, among other features, by the aedeagus anterior half almost membranous.

87. Bulbus ejaculatorius - aedeagus joint: (0) dorsal, subanterior; (1) dorsal, middle; (2) dorsal, anterior.

88. Aedeagal posterior projection, dorsal band (Fig. 4A): (0) wide; (1) wide, all dorsal half; (2) wide, posterior half slightly projected to right side; (3) narrow, posterior half projected to right side; (4) wide, posterior half strongly projected to right side.

89. Aedeagal posterior projection, ventral band (Fig. S3E): (0) narrow, as long as dorsal band; (1) absent; (2) narrow, half as long as dorsal band; (3) narrow, placed on right side, spoon-shaped apex; (4) narrow, placed on right side, 2 × as long as dorsal band.

90. Aedeagal posterior projection, right band (Fig. 4B): (0) absent; (1) subdorsal, narrowed posteriorly, as long as dorsal band; (2) subventral, as a strongly sclerotized line, projected to vesica basal 1/4 at list; (3) subventral, as a more sclerotized area, sometimes as a band, slightly projected into vesica; (4) subventral, as a strongly sclerotized line, slightly projected into vesica, apex Spanish fan like.

Lafontaine mentions as a diagnostic character for *Agrotis*: “hooklike shape to the sclerotized apex of aedeagus on right side” and San Blas: “aedeagus projected into the vesica in the following way: a dorsal strip with posterior half projected ventrolaterally through right margin, a right ventrolateral strip, and a strip close to the latter, like a band with posterior 1/3 forming a 1/4 of a spiral.” With the three characters above (88–90), it was tried to codify this variation and also some others variations seen between genera and species.

91. Aedeagus / valve length ratio: (0) equal or less than 0.54; (1) between 0.55 and 0.94; (2) more than 0.94.

92. Vesica / aedeagus length ratio: (0) equal or less than 4.4; (1) between 4.5 and 8.0; (2) more than 8.0.

Long looping vesica is mentioned by Lafontaine and San Blas as a diagnostic character for *Agrotis*.

93. Scobinated sclerotized area close to vesica apex: (0) absent; (1) present.

94. Basal ventral swelling (Fig. 4C): (0) absent; (1) present.

95. Left basal diverticulum (Fig. 4F): (0) absent; (1) boot shaped; (2) subcylindrical or globose.

96. Cornutus on left basal diverticulum (Fig. 4F): (0) absent; (1) present.

97. Right basal diverticulum (Fig. 4D): (0) absent; (1) vestigial; (2) subcylindrical or globose.

Presence of this character (even vestigial) is a diagnosis for the genus *Agrotis*, according to San Blas.

98. Left basal dorsal swelling (Fig. 4E): (0) absent; (1) present.

Lafontaine and San Blas mention a basal swelling on vesica of aedeagus (character 95) as diagnostic character for *Agrotis*, but there is also a similar dorsal swelling in some other species (character 99). Perhaps it is only a strong twist on the vesica that changes the position of the swelling but, as there is no evidence of this assumption, they are treated here as separate characters.

99. Dorsal/posterior diverticulum (Fig. 4F): (0) absent; (1) present.

100. Median diverticulum (Fig. 4F): (0) absent; (1) bifid; (2) conical, posterior and dorsally curved; (3) subcylindrical.

101. Cornutus on median diverticulum: (0) absent; (1) one; (2) two.

102. Subapical diverticulum (Fig. 4F): (0) absent; (1) present.

103. Apical diverticulum (Fig. 4F): (0) absent; (1) present; (2) vestigial.

104. Left basal spined band on vesica: (0) absent; (1) present.

Presence of this character is a diagnosis for the genus *Agrotis*, according to Lafontaine and San Blas.

105. Size of spines on vesica basal spined band: (0) big, as in *Agrotis segetum*; (1) small, as in *A. araucaria*.

106. Vesica / basal spined band length ratio: (0) equal or less than 30; (1) between 31 and 90; (2) more than 90.

107. Vesica shape (Fig. 4G): (0) straight; (1) helical with close spins, apex straight; (2) helical with close spins; (3) helical with close spins, apex as a fraction of wide loop; (4) looping, as wide loops.

Long looping vesica is a characteristic of *Agrotis* species and a vesica helical, with a variable number of tight loops is characteristic of *Feltia* and *Feltia tent.*, according to Lafontaine and San Blas.

108. Vesica apical swelling: (0) absent; (1) gradually narrowing; (2) widened.

109. Bulbus ejaculatorius / vesica length ratio: (0) equal or less than 0.94; (1) between 0.95 and 1.94; (2) more than 1.94.

Female genitalia

110. Anal papillae length: (0) 2 × as wide as long; (1) 2 × as long as wide; (2) 4 × as long as wide; (3) as long as wide.

Length and shape of anal papillae are used by Lafontaine to separate subgenera within *Feltia*.

111. Anal papillae hair-like setae: (0) thin and long setae; (1) thick setae.

112. Posterior apophysis / anterior apophysis length ratio: (0) equal or less than 1.54; (1) between 1.55 and 1.94; (2) more than 1.94.
113. Ostium bursae / 8th abdominal sternite width: (0) same width; (1) $3/5 \times$ as wide as 8th sternite; (2) $1/4 \times$ as wide as 8th sternite; (3) $1/3 \times$ as wide as 8th sternite; (4) $1/2$ as wide as 8th sternite.
114. Antrum: (0) absent; (1) present.
115. Ductus bursae sclerotization pattern: (0) membranous; (1) ventral band and a dorsal blade-like band; (2) diffuse on posterior half.
116. Corpus bursae / ductus bursae length ratio: (0) equal or less than 1.54; (1) between 1.55 and 3.44; (2) more than 3.44.
117. Appendix bursae / corpus bursae length ratio: (0) equal or less than 1.0; (1) between 1.1 and 3; (2) more than 3.0.

Long looping appendix bursae is a diagnostic character for the genus *Agrotis*, according to Lafontaine and San Blas.

118. Corpus bursae shape: (0) bag shaped; (1) "8" shaped; (2) tube like.
119. Corpus bursae apex shape: (0) rounded; (1) subtriangular; (2) bag shaped.
120. Signa on corpus bursae: (0) one; (1) two; (2) absent.
121. Appendix bursae origin side (Fig. S3F): (0) left side; (1) right side; (2) right ventral place; (3) without appendix.
122. Appendix bursae shape (Fig. S3G): (0) circular; (1) tube like; (2) as a corpus bursae widening.
123. Appendix bursae apex shape: (0) subtriangular; (1) bag shape; (2) rounded.
124. Ductus seminalis place of origin (Fig. 4H): (0) apex corpus/appendix bursae; (1) laterally, near appendix bursae apex; (2) subapical to appendix bursae apex.
125. External lateral pouches at side of anterior apophysis: (0) absent; (1) present.

A [Char. 45]

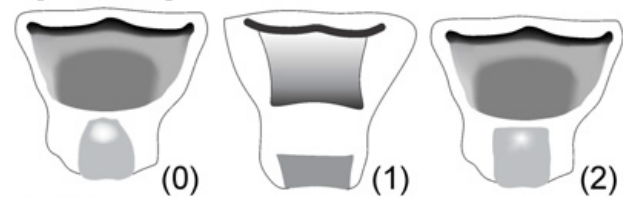

B [Char. 54]



C [Char. 56]



D [Char. 59]

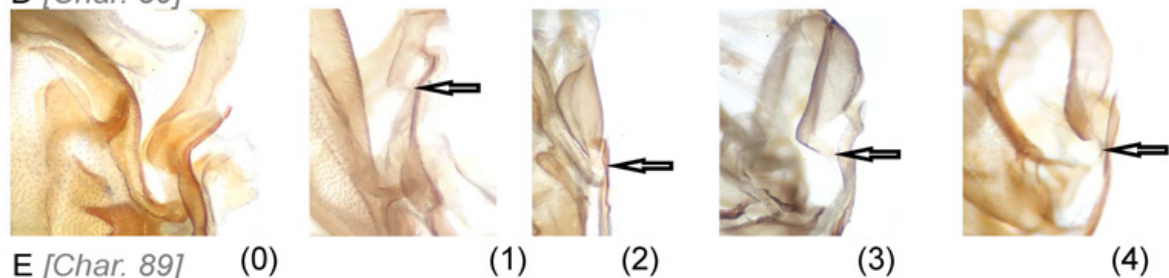

E [Char. 89]

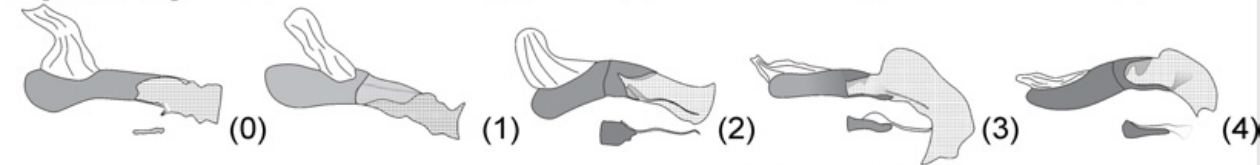

F [Char. 121]

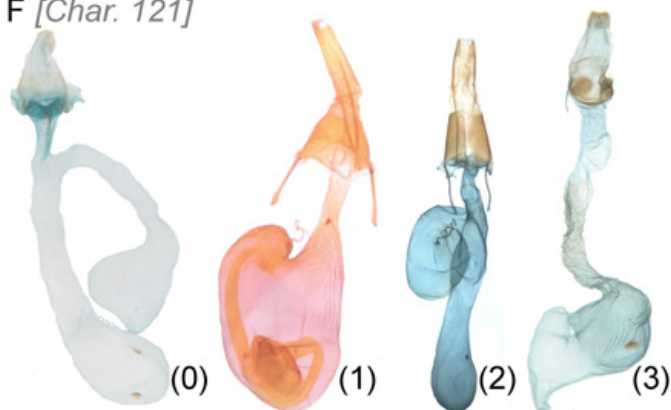

G [Char. 122]

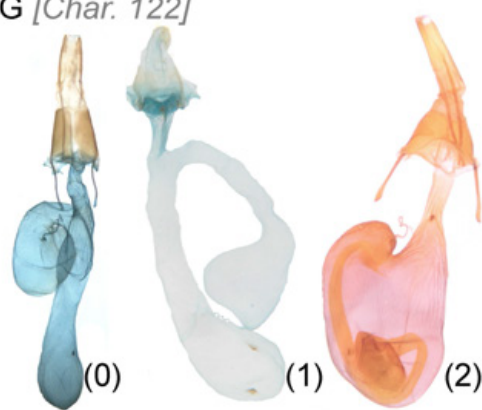

S04

".nex" Mesquite file in Attachments files

S05

".tnt" TNT file in Attachments files

S06

".run" INT macro/script file in Attachments files

Tree 0:

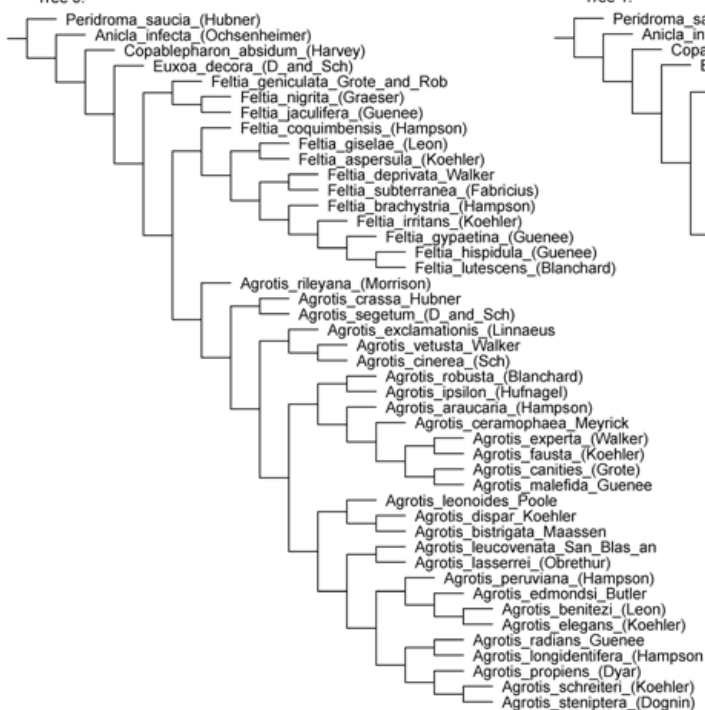

Tree 1:

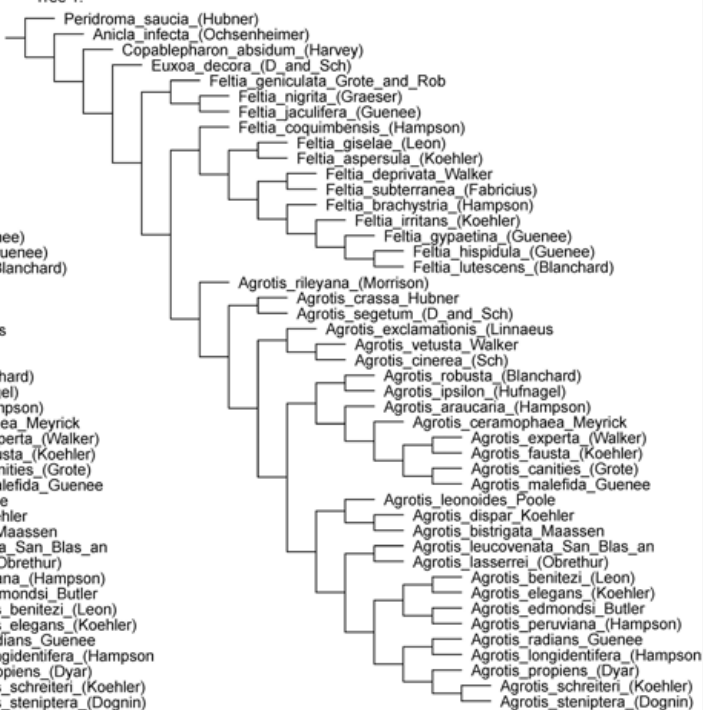

Tree 2:

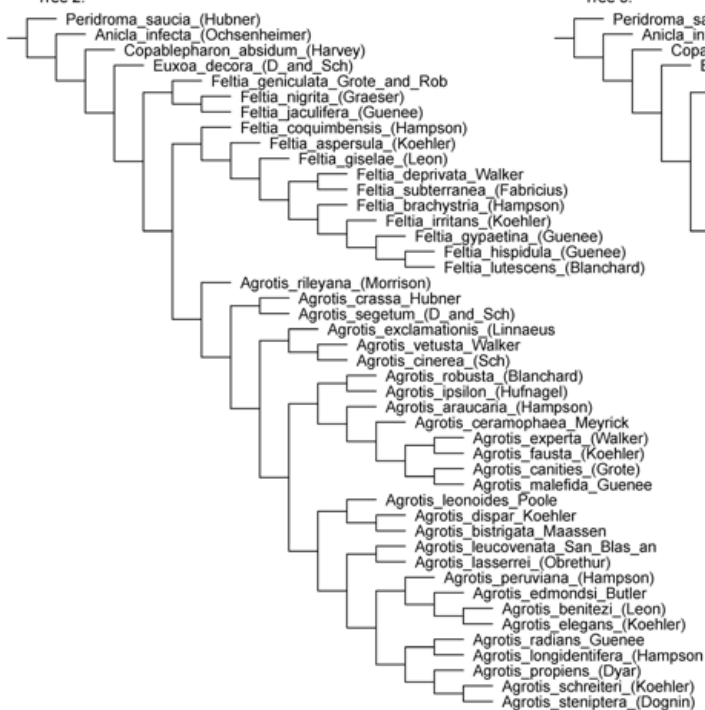

Tree 3:

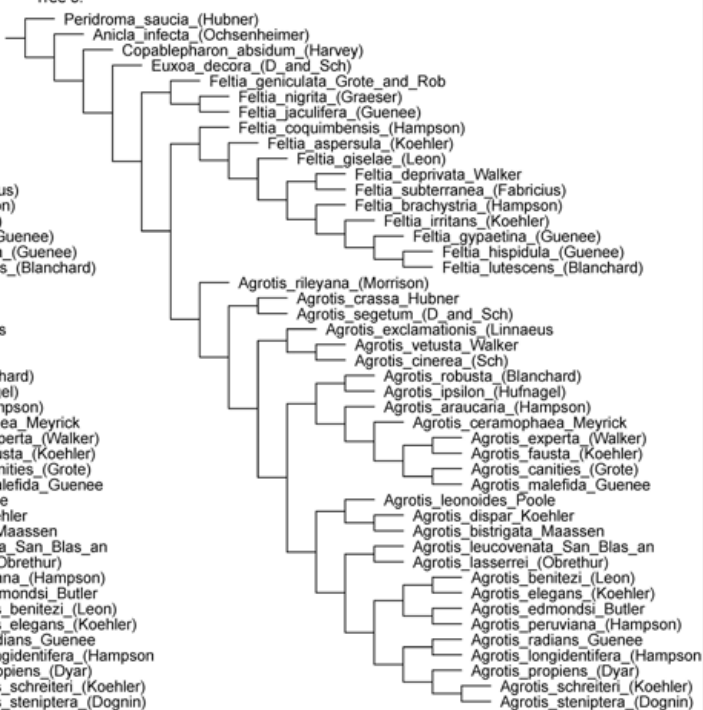

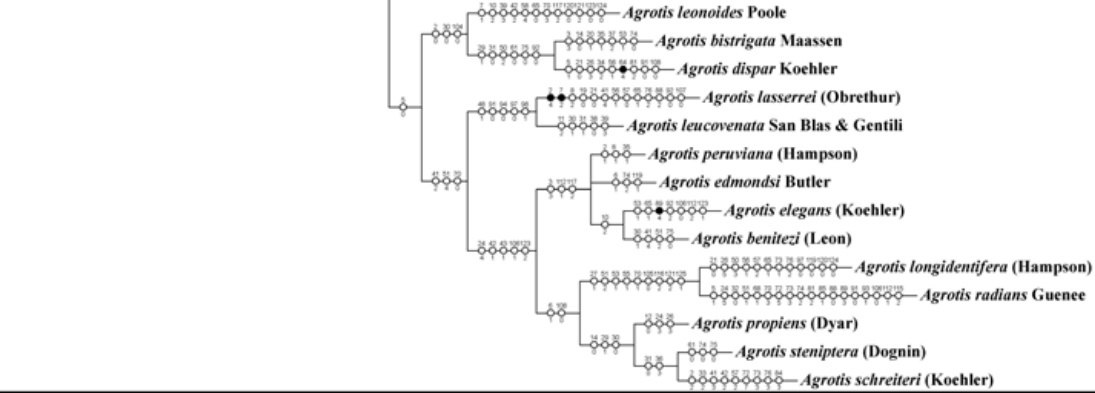
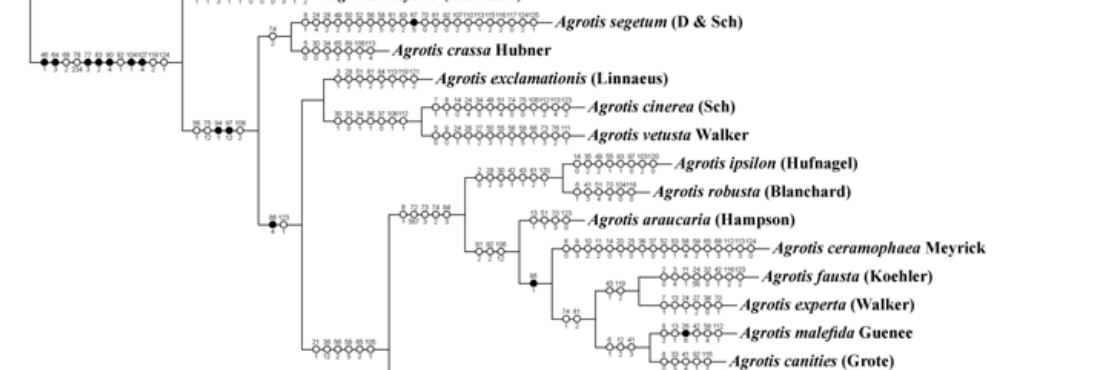
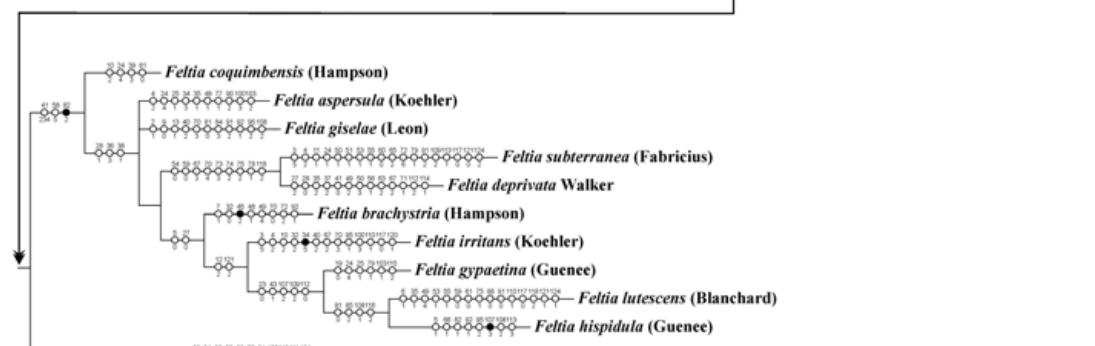
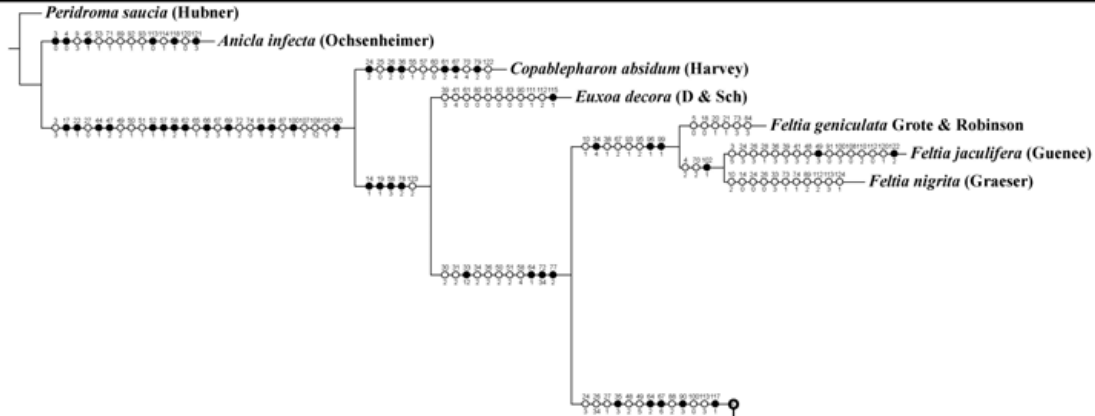

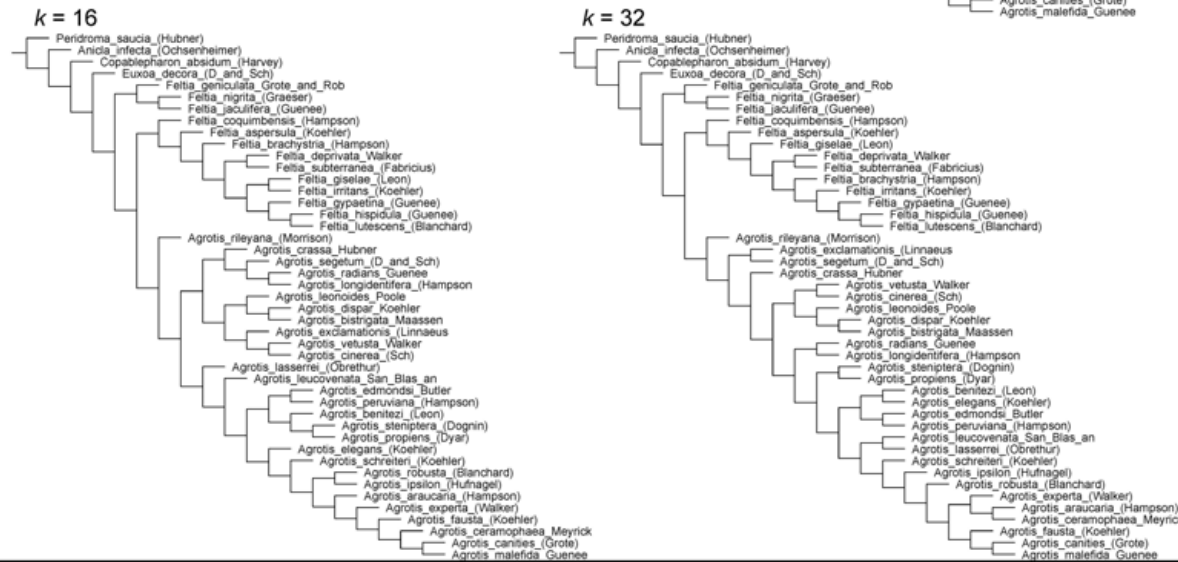
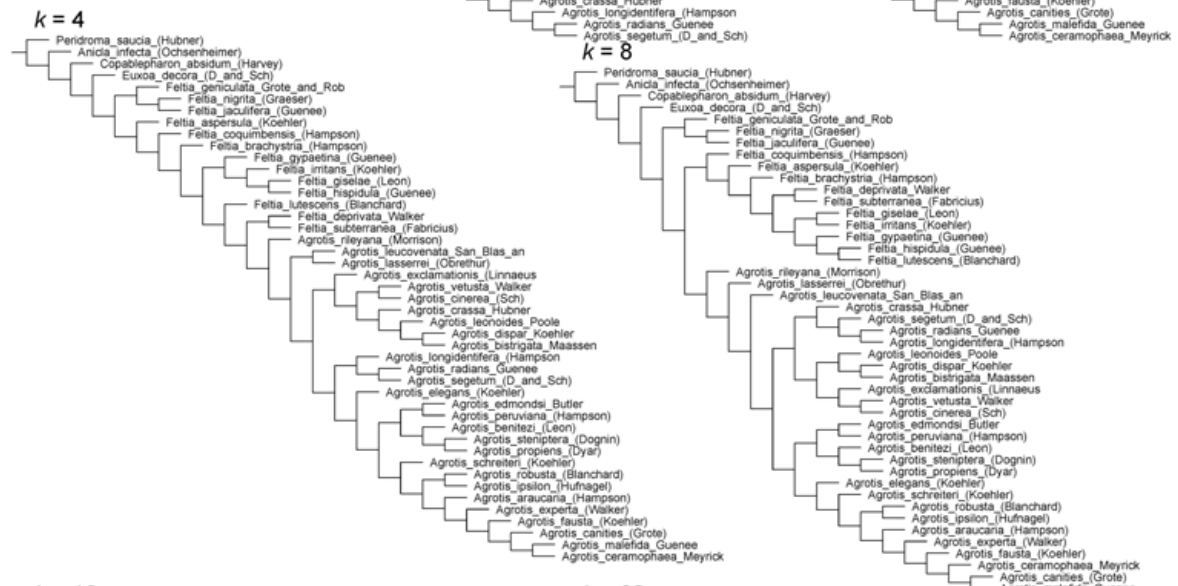
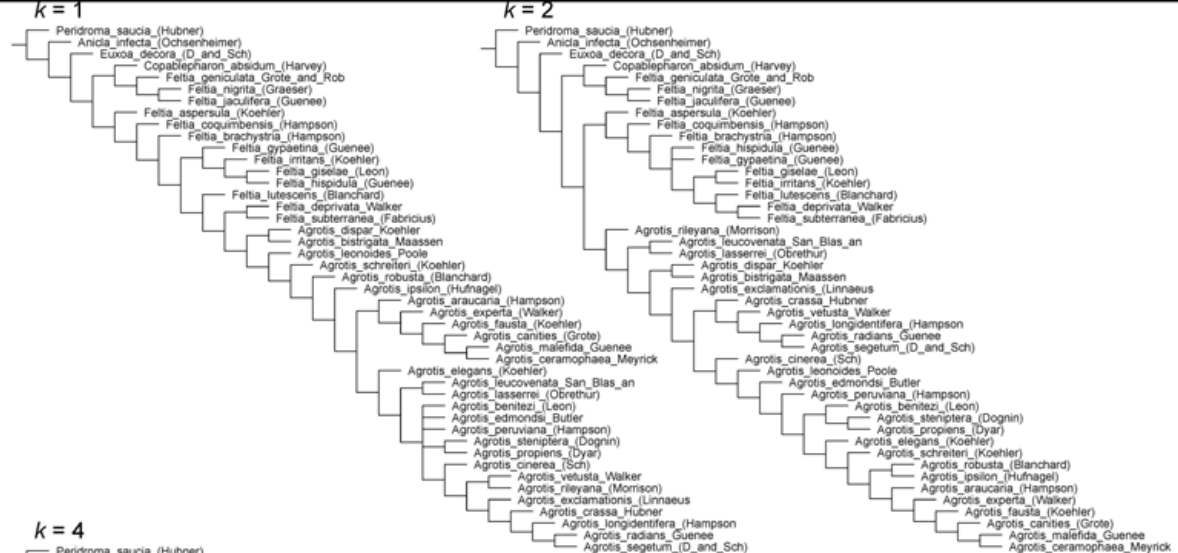

k = 64

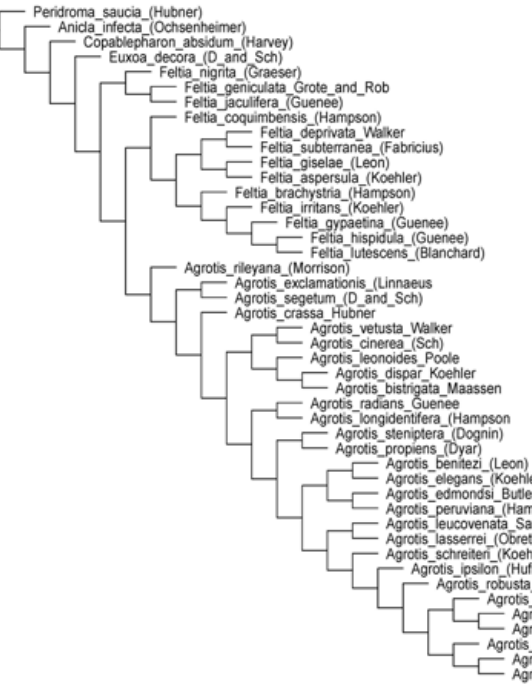

k = 128

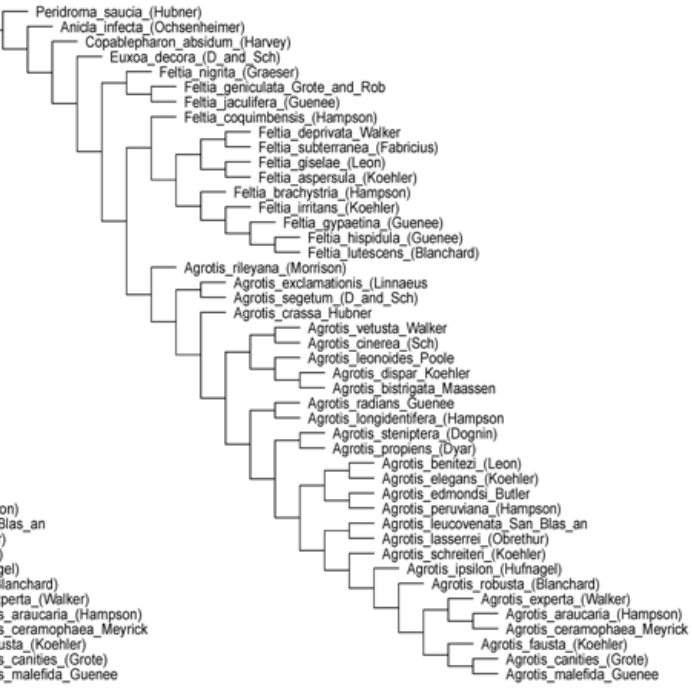

k = 256

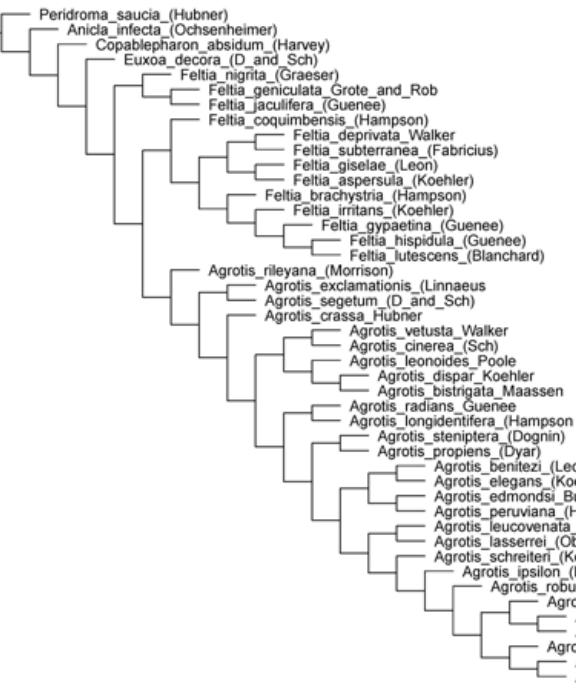

k = 512

