

# A DEVICE TO RECORD ULTRA-RAPID COOLING PROFILES

Leonardo Juan de Paz<sup>1,2</sup>, Daniel Adolfo Graf<sup>1,2</sup>, Angel Luis Scandizzi<sup>1</sup>, Edgardo Elvio Guibert<sup>1</sup> and Joaquin Valentin Rodriguez<sup>1\*</sup>

<sup>1</sup> Centro Binacional (Argentina -Italia) de Investigaciones en Criobiología Clínica y Aplicada (CAIC), Universidad Nacional de Rosario, Avda. Arijón 28 bis, S2011BXN Rosario, Argentina. <sup>2</sup>Servicio de Electrónica y Óptica, Facultad de Ciencias Bioquímicas y Farmacéuticas, Universidad Nacional de Rosario, Suipacha 531-S2002LRK Rosario, Argentina.

\*Corresponding author email: jrodrig@fbioyf.unr.edu.ar

## Abstract

This work deals with the construction and performance of a measuring system capable of estimating temperature at sufficiently high speed (up to 1000 samples/sec). Due to its simple design and the utilization of standard materials, it could serve to recording the cooling profile of ultra-rapid procedures. An immersion device was also developed with the purpose of normalize the penetration speed of the sample in the LN<sub>2</sub>. The device allows also the comparative analysis of different cooling profiles. The system consists of an immersion device of the sample in the cooling agent, a temperature measurement system developed by Kleihans F and a laptop computer. To test the system, we recorded the cooling profiles of 10 µL of distilled water and 6 M glycerol solution, obtaining a cooling rate of 8732 °C.min<sup>-1</sup> and 4441 °C.min<sup>-1</sup> respectively. Also we determine a cooling rate of 204.012 °C.min<sup>-1</sup> during the immersion of the thermocouple assembly in LN<sub>2</sub>. Although, the same device, with small technical modifications related to the handling of the sample, could be used to evaluate the recovery from LN<sub>2</sub> temperature to room temperature (re-warming).

**Keywords:** ultra-rapid cooling, vitrification, cooling rate, thermal history

## INTRODUCTION

Cryopreservation techniques use low temperatures to avoid aging and degradation of biological samples. Nevertheless, the fundamental limitation for the use of these techniques in the preservation of living cells (in the form of suspended cells, tissues or complete organs) are the damages caused during the process of cooling to storage temperature and re-warming to room temperature of the samples. These damages have been related to the intracellular or extracellular ice formation (IIF and EIF) (6).

Some of the methods developed to avoid ice formation require the use of rapid (10<sup>3</sup> - 10<sup>4</sup> °C.min<sup>-1</sup>) to ultra-rapid (up to 10<sup>5</sup> - 10<sup>6</sup> °C.min<sup>-1</sup>) cooling velocities (3). Under certain specific conditions, ultra rapid cooling has been suggested so as to avoid the ice formation inducing a glassy, non-crystalline state (vitrification).

This glass transition is not a phase transformation in the thermodynamic sense, its occurrence is determined by the history of the material, and is dependent on the exact conditions of the experiment (7). The cooling profile, as the graphical representation of the temperature evolution during the process, is then an important parameter in the design, description and analysis of any rapid or ultra-rapid cooling protocol for cryopreservation.

The immersion of a sample in liquid nitrogen (LN<sub>2</sub>) is a simple method to obtain high, although uncontrolled, cooling rates. The objective of this work is to implement a simple measuring system capable of estimating temperature at sufficiently high speed, so as to allow a thermal history recording of such procedures. An immersion device was also developed, in order to normalize the penetration speed of the sample in the LN<sub>2</sub>.

The use of a device to insure a uniform velocity of immersion of the sample in the cooling bath was previously evaluated in the literature (5). Here we combine this idea with a modern and relatively inexpensive temperature measurement system developed by Kleinhans (4). With the use of an optical arrangement to synchronize cooling profiles the entire device allows not only the estimation of the cooling rate but also the comparative analysis of different cooling profiles.

## MATERIALS AND METHODS

### *Temperature Measurement*

The temperature measurement system as described by Kleinhans (4) has been used and is shown in Figure 1. A temperature sensor (50  $\mu$ m type T Unsheathed thermocouple, Omega Engineering, Inc.) is connected to an USB dual channel oscilloscope (DS1M12 “Stingray”, USB Instruments, Easy Sync Ltd.) attached to a laptop computer. The entire system allows a recording rate larger than 1000 samples/sec. This rate is almost three orders of magnitude higher than the sampling rate in most of the digital thermometers available in the market. All potential compensations and temperature/time calculations were made using MS Excel Analysis Spreadsheet prepared for analysis of type T thermocouple data, kindly provided by F W Kleinhans. The measuring element is mounted on a stainless steel tube ( $\varnothing$ : 3 mm) which, not only facilitates the manipulation of the TC, but also provides support for the sample reservoir (see Figure 2).

### *Immersion Device and Synchronization:*

Traditionally, so as to obtain ultra rapid cooling rates, the samples were plunged into the LN<sub>2</sub> manually, and the cooling process was characterized by an estimated cooling rate. On an alternative approach, the temperature profile is recorded during the entire process. This “thermal history” (temperature as function of time) of the sample can be compared to other thermal histories of multiple samples by different mathematical and statistical methods.

With any of both approaches, the penetration speed of the sample in the LN<sub>2</sub> is one of the least reproducible variables in the system. To reduce this lack of repeatability, we have designed a mechanical system in which the sample recipient and the sensor element are mounted on a mobile carrier. This carrier moves along a cylindrical guide forced only by gravity. In fact, the sample practically falls into the LN<sub>2</sub>. The carrier and the guide (along with the optical sensors) were recycled from an old HP 670 Inkjet printer. One of the main reasons for using these parts is the fact that they were manufactured with almost no grip between the guide and the carrier. This reflects on a high repeatability of the movement, forced by a constant “variable”: gravity.

We use two optical sensors separated by 96 mm (Figure 2), and a barrier attached to the mobile carrier, to evaluate the normalization of the penetration speed (PS). The signals from these sensors are mixed by a simple electronic device, powered by a 9v DC external

source, which is connected to Channel B of the oscilloscope, allowing the simultaneous recording (Figure 3) of both signals (optical sensors and Tc.) The reproducibility of the process of immersion is characterized by measuring the time required for the barrier to move from the first to the second sensor. Our system shows an acceptable normalization of the immersion rate with a time between sensor signals of  $70 \pm 1$  msec, when the temperature is  $25^{\circ}\text{C}$ . We also tested the system at  $15^{\circ}\text{C}$  obtaining a time between sensors of  $79 \pm 2$  msec (all data is ten times replication mean  $\pm$  SD; resolution = 1msec). This difference in performance, although may seem significant for room temperature fluctuations of 10 degrees, does not represent a practical limitation if the room temperature of the laboratory is maintained relatively stable (not larger than  $1^{\circ}\text{C}$  or  $2^{\circ}\text{C}$  variations).

In order to compare different cooling profiles, the ascending or descending flanks from any of both sensors can be used as a synchronization event. If the entire process of cooling is to be evaluated, the synchronism event must occur previous to the penetration of the sample in the  $\text{LN}_2$ .

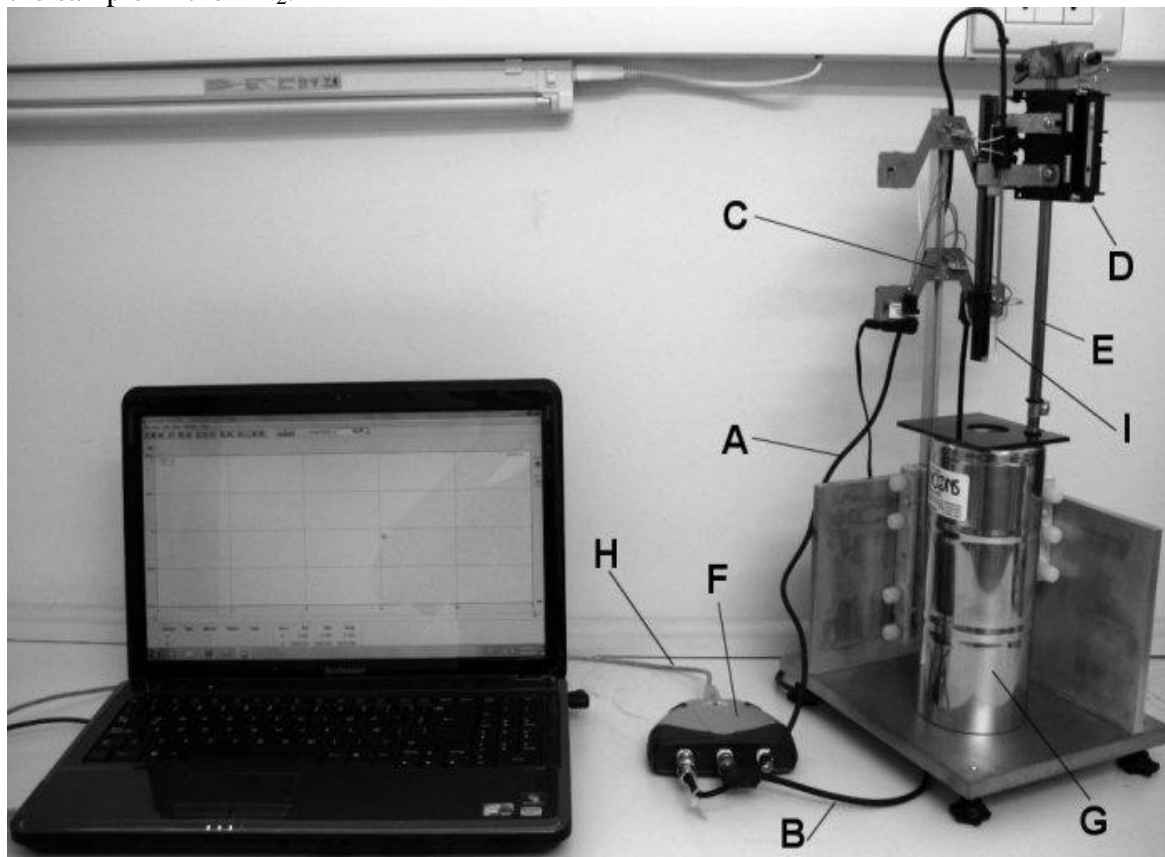

**Figure 1: The entire setup.** The Measure system and the immersion device attached to a laptop computer via an USB based digital oscilloscope. A) Thermocouple signal, B) Optical sensors signal, C) Mixer circuit and sensors, D) Mobile carrier, E) Guide, F) DS1M12 Oscilloscope, G ) Dewar Flask containing  $\text{LN}_2$ , H) USB connection and I) Sample Recipient

#### *Sample container and geometry:*

Well known is the influence of the sample geometry in the cooling profile. The volume of the sample not only affects the “numerical cooling rate”, but may also modify the curve shape, which, in larger volumes, is also affected by the position of the TC in the sample. This is a direct effect of the non-homogeneous distribution of the temperature in the sample during the cooling process.

The sample container plays also a determinant role in the cooling rate. Both the wall material and the geometry affect directly the heat exchange between the sample and the  $\text{LN}_2$ .

All these variables and many others, not mentioned here, are common to the majority of temperature measuring systems, and must be kept in consideration when cooling curves are compared and analyzed.

In this work and only as an example, we use a polyvinyl cylindrical tube as sample recipient. Other recipients available in our laboratory (thin wall PCR tubes; Cryotops) were also tested as sample containers (data not shown). Modifications to the TC mounting can be made in order to use different sample containers.

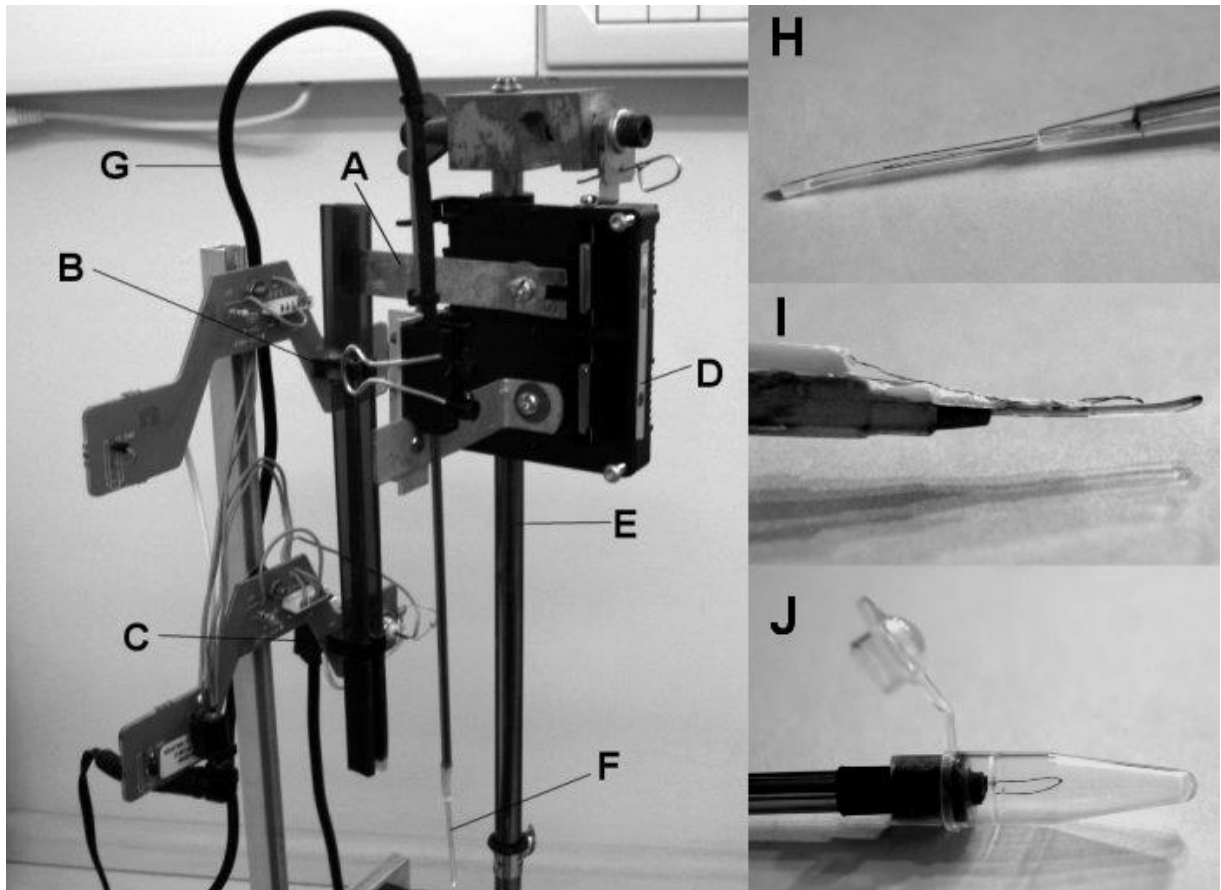

**Figure 2: Immersion device, optical system and sample container.** The mobile carrier movement is indicated by the two headed arrow. A) Opaque barrier, B) Optical Sensor N°1, C) Optical Sensor N°2, D) Mobile carrier, E) Guide, F) Sample container and G) Thermocouple Signal. On the right side, different assemblies of sample container and thermocouple are showed H) Polyvinyl cylindrical tube I) Cryotop-like carrier J) Thin wall PCR tubes

#### *Estimation of cooling rate*

Linearization of the region between first value beneath 233 K (-40°C) and first value above 153K (-120°C) is used here to estimate the rates of cooling by minimum mean squares. It should be noted that uncontrolled freezing protocols (i.e. immersion of the sample in a specific cooling agent) do not show constant cooling rates during the process but instead a marked variation with sample temperature. In different systems, the cooling curves may also show complex behaviors (i.e. freezing plateau, multiple cooling rates). All these characteristics, the linearization region, or even the determination method, must be reviewed (visually fit slope, exponential regression and more complex signal analysis methods can also be used) and adapted to the specific experiment. In such cases, other parameters of the cooling curve, as the plateau period and temperature, difference between multiple cooling rates, etc. may be evaluated in relation with system variables.

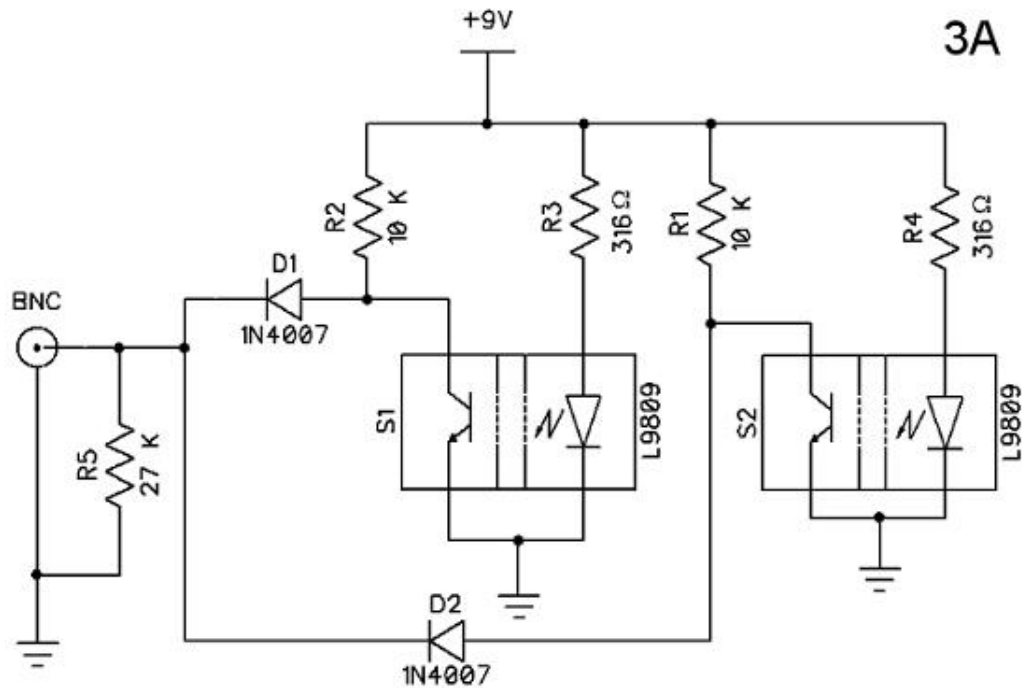

3A

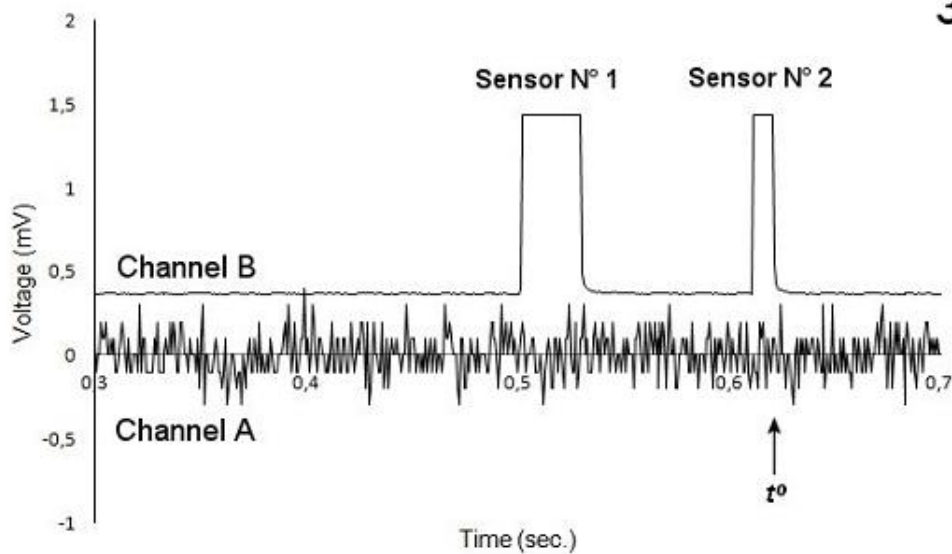

3B

**Figure 3: Mixer Circuit and Synchronization Signals.** Optical Sensors circuit is showed on Figure 3A. When the opaque barrier passes between the light emitter and the receptor on any of both sensors (S1 or S2), a pulse is generated in the signal output (BNC). Figure 3B shows in detail, the region of the profile (previously to the Voltage-Temperature conversion) where the signals from the sensors are recorded (differences in pulse width are due to gravity acceleration). The signal from the temperature measuring system (channel A) is around 0 mV (Room Temperature) and the signal from the sensors (channel B) has been scaled down to fit the graphic. We establish  $t_0$  for synchronization at the last descending flank (generated by sensor N°2).

## RESULTS

### *Maximum system response:*

Our first tests evaluated the maximum response of the measuring system. Previous work estimated the highest cooling rate measurable with a 50  $\mu\text{m}$  type T thermocouple around  $1.6 \times 10^5 \text{ }^\circ\text{C} \cdot \text{min}^{-1}$  (4).

We recorded the cooling curve during the immersion of the TC assembly in the  $\text{LN}_2$ , and calculated the cooling rate by linear regression in the 0.85 – 0.88 sec. region (16 measures at 2 msec. sample rate) resulting on a cooling rate of  $204.012 \text{ }^\circ\text{C} \cdot \text{min}^{-1}$ . This result sets the maximum tracking rate around  $2 \times 10^5 \text{ }^\circ\text{C} \cdot \text{min}^{-1}$  which is sufficient for our purposes.

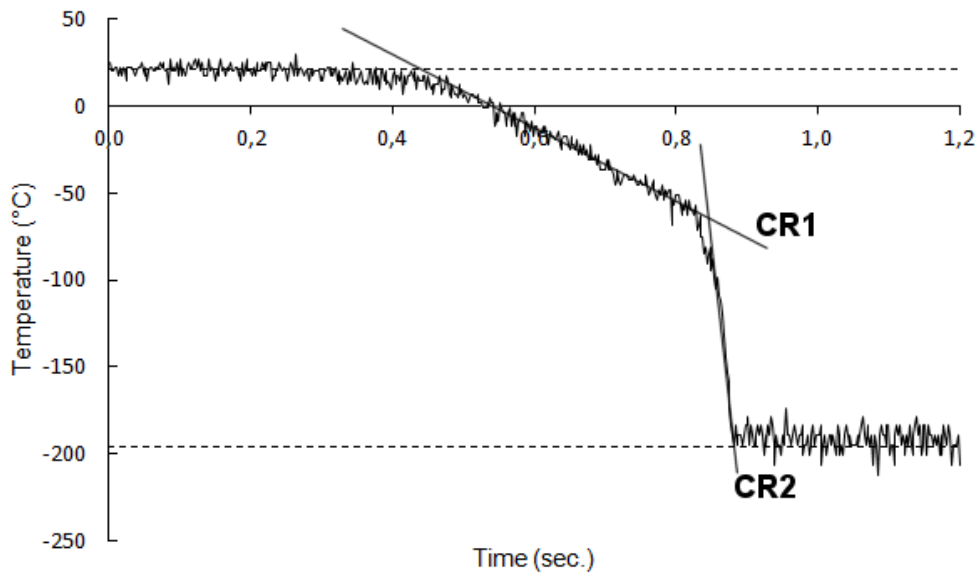

**Figure 4:** Two step cooling profile recorded during the immersion of the TC in the  $\text{LN}_2$ . Sample rate is 500  $\mu\text{sec}$ . Maximum response of the system was estimated from the cooling rate of the second step (CR2). Top dotted line is room temperature ( $21 \text{ }^\circ\text{C}$ ) and bottom dotted line is  $\text{LN}_2$  temperature ( $-196 \text{ }^\circ\text{C}$ )

This cooling profile (Figure 4) shows another very important characteristic of the system. When using  $\text{LN}_2$  as cooling agent, the sample surface produces a superficial phenomenon known as film boiling (or Leidenfrost effect) in which the sample is surrounded by nitrogen vapor during a period of time and the heat transfer is much slower. This effect produces a two-step cooling profile. The first (CR1), in which the heat transfer is between the TC wire and the nitrogen vapor (probably at  $-196 \text{ }^\circ\text{C}$  or nearby), and the second stage (CR2) in which the heat transfer is between the TC wire and the  $\text{LN}_2$ .

### *Standard cooling profile recording*

Two cooling profiles are showed as an example (Figures 5). 10  $\mu\text{L}$  of distilled water (sample A) and 6 M (sample B) glycerol solutions contained on a polyvinyl cylindrical tube (inner diameter: 0.5 mm) were immersed in  $\text{LN}_2$ . The profiles show differences not only in the cooling rates but also in the shape of the profile. Cooling rate measured by the  $-40^\circ\text{C} / -120^\circ\text{C}$  linearization procedure were  $8844 \text{ }^\circ\text{C} \cdot \text{min}^{-1}$  in sample A and  $4441 \text{ }^\circ\text{C} \cdot \text{min}^{-1}$  in sample B. Three times replication shows an average cooling rate of  $8868 \pm 187 \text{ }^\circ\text{C} \cdot \text{min}^{-1}$  for sample A and  $4222 \pm 191 \text{ }^\circ\text{C} \cdot \text{min}^{-1}$  for sample B (data is three times replication mean  $\pm$  SD).

A plateau is observed in the distilled water profile in the region of 1 - 2 sec. This is related to the crystallization of the sample (latent heat of crystallization). This plateau is not

observed (or it is significantly reduced) on the 6 M profile which is consistent with the prediction of glass formation (avoiding crystallization) when a glycerol solution of concentration larger than 40 – 45% (W/W) is rapidly cooled. In fact, rapid cooling is not even a necessary condition at such concentration (1, 2). Consequently 6M of glycerol was chosen, here, to ensure vitrification of the sample. Further inquiry into the possibly relationship between uncontrolled cooling profile data and the physical nature of the solid state achieved (pure crystalline phase, pure amorphous phase, or a mix of both) require a more extensive and detailed study.

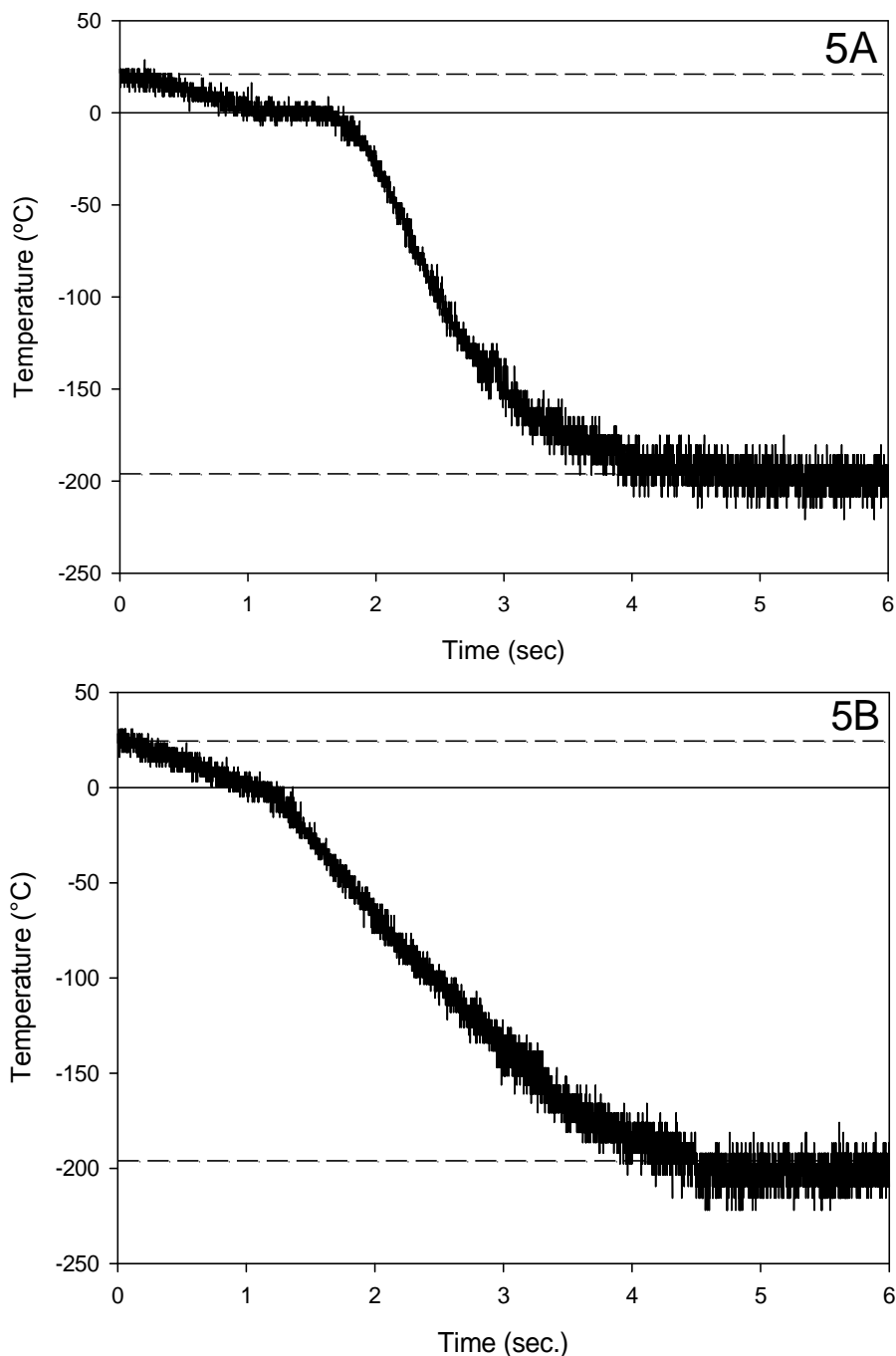

**Figure 5:** Cooling profiles recorded from the immersion of: (5A) 10 μL of distilled water and (5B) 10 μL of 6 M glycerol in the LN<sub>2</sub>. Top dotted line is room temperature (21 °C) and bottom dotted line is LN<sub>2</sub> temperature (-196 °C).

## DISCUSSION

The measurement system allows the characterization of the cooling process for different sample configurations. Relative attention is required in the assembly of the thermocouple and the control of different system variables which may affect the cooling process (e.g. LN<sub>2</sub> level, position of the TC wire on the sample, etc.). The immersion device normalizes the movement of the sample into the LN<sub>2</sub> and permits a more accurate tool for comparison of cooling rates from multiple combinations of sample containers, compositions, and other variables.

A hypothetic analysis could start with a characterization of the thermal history (by cooling rate estimation or by other type of cooling profile analysis) of a given sample during cooling in LN<sub>2</sub>. Supposing this thermal history is common to another sample processed in the same way, the cooling process of multiple samples could be carried out without sensing elements. Then other variables (e.g. % of survival in the case of cells suspensions) could be related to such thermal history.

In a different case, thermal history of multiple sample carriers could be recorded and analyzed to evaluate them for any potential application.

Not less important is the high applicability with a relative low cost of the entire system. Although this work centers on the cooling process, the same device, with small technical modifications related to the handling of the sample, could be used to evaluate the recovery from LN<sub>2</sub> temperature to room temperature (re-warming). Also, in the same way as with cooling, different characteristics of the re-warming profile may be related to the physical properties of the solid state of the sample before the re-warming.

**Acknowledgements:** We wish to thank Dr. F.W. Kleinhans for give us the software developed for analysis of temperature data. This work was funded by grant PIP-1208 from CONICET (Argentina), grant - Prot 19096/PT from Regione Autonoma Friuli-Venezia Giulia (Italy) and grant 1BIO176 from National University of Rosario (Argentina). This work was presented, in part, at the 2<sup>nd</sup> Workshop of Artificial Organs, Biomaterials and Tissue Engineering (OBI 2011) held on September 28/30, 2011 in Mar del Plata, Argentina. EEG and JVR are members of CONICET.

## REFERENCES

1. Berejnov V, Hussein NN, Alsaied OA, Thorne RE, (2006) *J Appl Cryst* **39**, 244-251.
2. Chang Z, Baust JG ,(1991) *Cryobiology* **28**, 268-278.
3. Kaktov I, Isachenko V, Isachenko E, Kim M, Lulat A, Mackay A, Levine F, (2006) *Int J of Refrig* **29**, 346 -357.
4. Kleinhans FW, Seki S, Mazur P, (2010) *Cryobiology* **61**, 231–233.
5. Luyet B, Gonzales F (1951) *Refrigeration Engng* **59**, 1191.
6. Mazur P (1984) *Am J Physiol* **247**, C125-C142.
7. Yavin S, Arav A, (2007) *Theriogenology* **67**, 81-89.