

Concordance of *CCR5* Genotypes that Influence Cell-Mediated Immunity and HIV-1 Disease Progression Rates

Gabriel Catano,^{1,2} Zoya A. Chykarenko,⁴ Andrea Mangano,⁵ J-M Anaya,⁶ Weijing He,^{1,2} Alison Smith,⁷ Rosa Bologna,⁵ Luisa Sen,⁵ Robert A. Clark,^{1,2} Andrew Lloyd,⁸ Ludmila Shostakovich-Koretskaya,⁴ and Sunil K. Ahuja^{1,2,3}

¹Veterans Administration Research Center for AIDS and HIV-1 Infection, South Texas Veterans Health Care System; Departments of ²Medicine; ³Microbiology and Immunology, and Biochemistry, University of Texas Health Science Center, San Antonio, Texas; ⁴Department of General Pediatrics and Pediatric Infectious Diseases, Dnepropetrovsk State Medical Academy, Dnepropetrovsk, Ukraine; ⁵Laboratorio de Biología Celular y Retrovirus and Servicio de Infectología, Hospital de Pediatría "J. P. Garrahan," Buenos Aires, Argentina; ⁶Center for Autoimmune Diseases Research (CREA), School of Medicine and Health Sciences, Universidad del Rosario, Bogota, Colombia; ⁷School of Psychology, University of Western Sydney, Penrith South; and ⁸Centre for Infection and Inflammation Research (CIIR), School of Medical Sciences, University of New South Wales, Sydney, NSW, Australia

We used cutaneous delayed-type hypersensitivity responses, a powerful *in vivo* measure of cell-mediated immunity, to evaluate the relationships among cell-mediated immunity, AIDS, and polymorphisms in *CCR5*, the HIV-1 coreceptor. There was high concordance between *CCR5* polymorphisms and haplotype pairs that influenced delayed-type hypersensitivity responses in healthy persons and HIV disease progression. In the cohorts examined, *CCR5* genotypes containing -2459G/G (HHA/HHA, HHA/HHC, HHC/HHC) or -2459A/A (HHE/HHE) associated with salutary or detrimental delayed-type hypersensitivity and AIDS phenotypes, respectively. Accordingly, the *CCR5*-Δ32 allele, when paired with non-Δ32-bearing haplotypes that correlate with low (HHA, HHC) versus high (HHE) *CCR5* transcriptional activity, associates with disease retardation or acceleration, respectively. Thus, the associations of *CCR5*-Δ32 heterozygosity partly reflect the effect of the non-Δ32 haplotype in a background of *CCR5* haploinsufficiency. The correlations of increased delayed-type hypersensitivity with -2459G/G-containing *CCR5* genotypes, reduced *CCR5* expression, decreased viral replication, and disease retardation suggest that *CCR5* may influence HIV infection and AIDS, at least in part, through effects on cell-mediated immunity.

Significant inter-individual variability in cell-mediated immunity (CMI) may underlie differences in susceptibility to diseases. Although *in vitro* data and studies in knockout mice have identified many host factors that influence CMI, informative model systems are generally

unavailable for evaluating how these factors may influence CMI status *in vivo* in humans.

Delayed-type hypersensitivity (DTH) skin test reactivity, a typical *in vivo* manifestation of CMI [1], correlates strongly with T cell responses *in vitro* [2, 3]. Because cutaneous DTH responses may serve as an informative model system to assess functional immune status *in vivo*, we evaluated the associations of *CCR5* genotypes with this correlate of CMI in healthy persons and then compared them with the impact of these *CCR5* variations on AIDS status. Our primary rationale was that DTH status of HIV-infected patients predicts clinical outcome, both before [2, 4] and after [5] initiation of antiretroviral therapy, and correlates with restoration of immune responsiveness [6]. Second, there is a strong association of polymorphisms in *CCR5*, the major HIV-1 coreceptor, with HIV and AIDS

Received 8 March 2010; accepted 16 August 2010.

Any opinions, findings and conclusions or recommendations expressed in this material are those of the authors and do not necessarily reflect the views of US Civilian Research and Development Foundation.

Potential conflicts of interest: None reported.

Reprints or correspondence: Dr Sunil K. Ahuja, University of Texas Health Science Center at San Antonio, VA HIV/AIDS Center, 7703 Floyd Curl Dr, San Antonio, Texas (ahuja@uthscsa.edu).

The Journal of Infectious Diseases 2011;203:263–272

© The Author 2011. Published by Oxford University Press on behalf of the Infectious Diseases Society of America. All rights reserved. For Permissions, please e-mail: journals.permissions@oup.com

1537-6613/2011/2032-0001\$15.00

DOI: 10.1093/infdis/jiq023

phenotypes [reviewed in [7]]. Homozygosity for a 32–base pair (bp) deletion ($\Delta 32$) in *CCR5* results in complete loss of *CCR5* expression and resistance to HIV acquisition [7]. In addition, single nucleotide polymorphisms (SNPs) in the *CCR5* promoter and *CCR5* haplotypes bearing distinct combinations of SNPs associate with particular phenotypes, including transcriptional activity [8], *CCR5* surface levels [9–11], HIV infectivity *ex vivo* [10, 12], and HIV susceptibility [7, 13–15]. Third, because both DTH [1] and *CCR5* [16, 17] impact on Th1 responses and *CCR5* influences overall T cell immunity [discussed in [17]], it was highly plausible that *CCR5* would affect CMI *in vivo* in humans, just as it does in murine models [4].

In support of this concept, we found previously in healthy persons that *CCR5* haplotype pairs associated with low DTH responses to the neo-antigen keyhole limpet hemocyanin (KLH) or the recall antigen purified protein derivative (PPD) were similar to those that associated with disease acceleration in HIV-infected adults [4]. However, these inferences were based on pooling *CCR5* genotypes of HIV-uninfected persons into 2 groups—those associating with DTH responses that were lower than versus equal to or greater than the average DTH response found in the overall cohort—and then demonstrating that these 2 categories of DTH-influencing *CCR5* genotypes correlated with HIV disease phenotypes [4]. This approach of pooling DTH-influencing *CCR5* genotypes was useful for increasing statistical power, but it precluded identification of the specific polymorphism(s) or *CCR5* haplotype pairs that have major influences on both CMI and HIV status.

The importance of defining specific genetic variations is underscored by reassessing the associations of *CCR5* levels and *CCR5-Δ32* heterozygosity. *CCR5* density can differ by as much as 20-fold on the surface of T cells from individuals lacking the *CCR5-Δ32* mutation, many of whom have levels similar to those of $\Delta 32$ heterozygotes [18, 19]. Similarly, surface density varies significantly among *CCR5-Δ32* heterozygotes [19, 20]. These variations have clinical implications, because some HIV-uninfected persons who are highly exposed to HIV have *CCR5* levels comparable to *CCR5-Δ32* heterozygotes [19, 21]. Thus, *CCR5* genotypes lacking *CCR5-Δ32* may contribute to low *CCR5* expression and a protective HIV and AIDS phenotype. Moreover, the associations of *CCR5-Δ32*-containing genotypes with HIV and AIDS may partly reflect the effects of the functional non- $\Delta 32$ *CCR5* haplotype.

We previously used linkage disequilibrium patterns and an evolutionary approach to classify polymorphisms in *CCR2* (V64I) and *CCR5* ($\Delta 32$ and promoter SNPs) into *CCR5* haplotypes designated as HHA to HHG*2 [8, 14]. *CCR5*-HHG*2 and *CCR5*-HHF*2 haplotypes bear the *CCR5-Δ32* and *CCR2-64I* polymorphisms, respectively [14]. These *CCR5* haplotypes have striking population-specific distributions [22] and associate with contrasting phenotypes relevant to HIV and AIDS. *CCR5*-HHA, the ancestral haplotype [8], is prevalent among

persons of African descent [14, 22]. *CCR5*-HHA-specific regulatory and/or promoter sequences correlate with the lowest transcriptional activity [8]. *CCR5*-HHA associates with HIV disease retardation in African-Americans, whereas *CCR5*-HHC does so among European-Americans [14]. By contrast, *CCR5*-HHE-specific regulatory and/or promoter sequences associate with the highest transcriptional activity [8], surface expression [9], and HIV and AIDS susceptibility [7, 13–15].

Given these *CCR5* haplotype-phenotype relationships, it was conceivable that pairing of the $\Delta 32$ -containing HHG*2 haplotype with HHE would associate with detrimental HIV and AIDS phenotypes, whereas its pairing with HHA, HHC, or HHF*2 would associate with protective HIV and AIDS phenotypes. Indeed, the existence of these 2 categories of *CCR5-Δ32*-containing genotypes is supported by 3 lines of evidence. First, Kawamura et al [12] found that Langerhans cells bearing HHE/HHG*2 exhibited increased *ex vivo* susceptibility to productive HIV R5 infection, compared with all other HHG*2-containing genotypes. Second, HHE/HHG*2 is associated with HIV disease acceleration and increased risk of acquisition of HIV [15]. Finally, Tang et al [23] reported that HHA/HHG*2 and HHF*2/HHG*2 accounted for much of the HHG*2 haplotype-related effects on HIV disease, whereas, we [14, 15], Martin et al [13], and Hladik et al [24] found that HHC/HHG*2 (designated P4/ $\Delta 32$ in [13]) associated with favorable HIV disease phenotypes.

This reappraisal of the associations of *CCR5-Δ32* heterozygosity highlights the complexity of the *CCR5* genotype-HIV phenotype relationships and the importance of accounting for both *CCR5* haplotypes when evaluating the associations of *CCR5* polymorphisms. Failure to do so may obscure *CCR5* genotype-phenotype relationships and preclude identification of the full repertoire of *CCR5*-dependent genetic factors that correlate with phenotypes, such as CMI and susceptibility to HIV and AIDS. Therefore, to evaluate the full range of mechanisms by which *CCR5* may influence HIV pathogenesis, we sought here to identify the specific *CCR5* genetic determinants that associate with both CMI and AIDS status. To ensure robust analyses, we evaluated 2 distinct cohorts of HIV-infected children and 2 separate cohorts of normal individuals in whom CMI status was assessed by cutaneous DTH responses to either KLH or PPD.

MATERIALS AND METHODS

The primary cohort for evaluation of the association of *CCR5* genotypes with DTH responses comprised a previously described cohort of 206 healthy HIV-uninfected adults from Australia in whom cutaneous DTH responses to the neoantigen KLH were assessed [4, 25]. In brief, the cohort was comprised of 110 male participants and 96 female participants, with 137 (66%), 66 (32%), and 3 (1%) being Caucasian, Asian, and unknown ethnicity, respectively. The methods for assessment of

DTH responses to KLH after presensitization were reported [4, 25]. For replication, we investigated a previously described Colombian cohort of 172 persons in whom the tuberculin skin test (purified-protein derivative [PPD]) was applied [4]. As previously [4], because a low DTH response to PPD could be attributable to lack of prior exposure to either *Mycobacterium tuberculosis* or vaccination with bacilli Calmette-Guerin, genetic association studies were limited to those in whom the PPD skin test exhibited ≥ 10 mm of induration ($n = 85$).

The primary cohort for evaluation of the associations of *CCR5* genotype with HIV and AIDS phenotypes comprised 178 perinatally infected Ukrainian children whose characteristics have been reported elsewhere [26]. For replication purposes, we also evaluated a previously described cohort of 347 HIV-infected Argentinean children [15]. The definition of AIDS used in both pediatric cohorts is the 1993 Centers for Disease Control and Prevention set of criteria for children. *CCR5* genotypes were determined as described elsewhere [14, 15].

DTH responses by *CCR5* genotypes were compared by Kruskal-Wallis and Mann-Whitney tests, and for the Australian cohort, the associations are reported for all participants and for the subset of European descent. The association of *CCR5* genotypes with rate of disease progression to AIDS was assessed by Kaplan-Meier survival analyses, log-rank, Wilcoxon tests, and Cox proportional hazards modeling. All statistical analyses were conducted using Stata, version 10 (StataCorp).

RESULTS

CCR5 SNPs and Haplotypes

The composition of *CCR2-CCR5* haplotypes is such that they can be dichotomized into 2 broad categories: *CCR5*-HHA, -HHB, -HHC and -HHD each bear -2459G/-2135T, whereas haplotypes HHE to HHG*2 bear -2459A/-2135C (Figure 1; [8, 14]). Because there is a strong linkage disequilibrium pattern between these 2 SNPs, hereafter we refer only to the polymorphism at -2459. First, we determined associations at the level of this SNP (-2459), and then for the aforementioned reasons, we undertook a systematic approach to identifying the specific *CCR5* haplotype pairs (Table 1) that bear -2459G and/or -2459A that associate with both DTH and AIDS status.

Associations of *CCR5* -A2459G

In healthy Australians, possession of -2459G/A and -2459A/A, compared with *CCR5* -2459G/G, associated with lower DTH responses to KLH (Figure 2A; $P < .05$ for comparisons of G/G versus either G/A or A/A, except for the comparison of G/G vs A/A in all persons, which was $P = .067$). In HIV-infected Ukrainian children, possession of -2459A/A-containing genotypes associated with a significantly faster disease course, compared with genotypes bearing -2459G/A or -2459G/G (Figure 2B). The latter associations of -2459G/G reflects the combined effects of

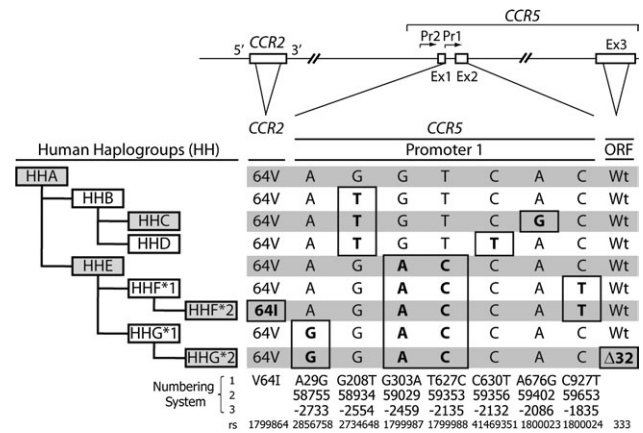

Figure 1. *CCR5* gene structure, polymorphisms, and haplotypes. The schema on the top depicts the *CCR5* gene structure with Pr1 and Pr2 referring to *CCR5* promoters 1 and 2, respectively [8]. Exons (Ex) 1 and 2 are the 5'-untranslated exons of *CCR5*, whereas exon 3 contains the open reading frame of *CCR5* [8]. Upstream of the *CCR5* gene is the *CCR2* gene. On the basis of the linkage disequilibrium patterns between the polymorphisms in the coding ($\Delta 32$) and noncoding (promoter) region of *CCR5* and the coding polymorphism (V64I) in *CCR2*, we previously used an evolutionary-based strategy to generate the *CCR5* human haplogroups (HH) shown below the *CCR5* gene structure [8]. These *CCR5* human haplogroups are designated as HHA to HHG*2, with HHF*2 and HHG*2 denoting the haplotypes that bear the *CCR2*-64I and *CCR5*- $\Delta 32$ polymorphisms, respectively. Because of its similarity to the chimpanzee *CCR5* sequence, the human *CCR5* HHA haplotype is classified as the ancestral *CCR5* haplotype [8]. Nucleotide variations relative to the ancestral sequence are shown in bold and bracketed. The various *CCR5* numbering systems used in the literature are denoted below the haplotype descriptions. Numbering system 1 is based on GenBank accession numbers AF031236 and AF031237; numbering system 2 is based on GenBank accession number U95626. Numbering system 3 is the numbering system in which the first nucleotide of the *CCR5* translational start site is designated as +1 and the nucleotide immediately upstream as -1 and is the nomenclature adopted previously [8]. rs numbers are indicated at the bottom most row.

3 *CCR5* genotypes (HHA/HHA, HHC/HHC, and HHA/HHC) (Table 1), suggesting that these genotypes that lacked *CCR5*- $\Delta 32$ (HHG*2) or *CCR2*-64I (HHF*2) associated with both increased DTH and disease retardation. In subsequent analyses, when possible, we compared the strength of the associations of other *CCR5* genotypes with the strengths of these salutary *CCR5* -2459G/G-containing genotypes.

Association of *CCR5* HHE-Containing Genotypes with DTH/AIDS Status

Consistent with their low prevalence in Europeans, HHB and HHD haplotypes were infrequent in the cohorts we evaluated (Table 1). Thus, the slow HIV disease course associated with -2459G/A-containing genotypes in Ukrainian children (Figure 2B) is a reflection of *CCR5* haplotype pairs that bear a -2459G-containing haplotype (HHA or HHC) and a -2459A-containing haplotype (HHE to HHG*2) (Figure 1 and Table 1).

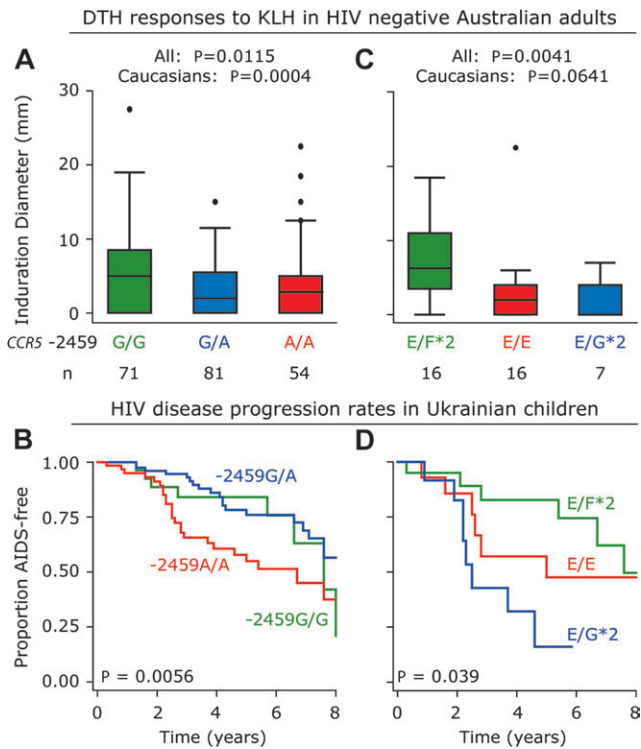

Figure 2. Association of *CCR5* -2459G/G, -2459G/A and -2459A/A-containing genotypes with DTH responses to KLH in HIV-uninfected Australians and rates of progression to AIDS in HIV-infected Ukrainian children. These 2 cohorts are the primary cohorts used for analyses of the associations of *CCR5* genotypes with DTH and AIDS status. **A** and **C**, Box and whisker plots (boxplots) depicting the median and upper and lower quartiles of the DTH responses in the HIV-uninfected Australians with genotypes containing *CCR5* -2459G/G (green), -2459G/A (blue), and -2459A/A (red) (these genotypes are indicated at the bottom of the panels). Box plots are shown for all participants. Significance values for all participants and the Caucasians in the Australian cohort are shown on the top. In the boxplots, the horizontal line within the box represents the median, with whiskers representing the maximum and minimum values, and the outliers are represented by black dots. **B** and **D**, Kaplan-Meier plots for time to AIDS (1993 Centers for Disease Control and Prevention criteria) for persons with genotypes containing *CCR5* -2459G/G (green plot), -2459G/A (blue plot), and -2459A/A (red plot). The boxplots and Kaplan-Meier plots are color-coded to indicate similarity in the genotypes studied for their association with DTH responses and rates of disease progression. In panels **C** and **D**, E/F*2, E/E and E/G*2 refer to HHE/HHF*2, HHE/HHE, and HHE/HHG*2, respectively, with HHF*2 and HHG*2 reflecting *CCR5* haplotypes that bear the *CCR2*-64I and *CCR5* Δ 32 polymorphisms, respectively.

Similarly, -2459A/A-containing genotypes are the conflation of several *CCR5* haplotype pairs (Table 1). Therefore, we next evaluated the influence of specific -2459A/A- or -2459G/A-containing genotypes on DTH and AIDS status.

In both the healthy Australians and HIV-infected Ukrainians, the most common -2459A/A-containing genotypes were HHE/HHF*2, HHE/HHE, and HHE/HHG*2 (Table 1). The hierarchy (increased to decreased) of the association of these genotypes with DTH responses was HHE/HHF*2 to HHE/HHE to HHE/

HHG*2 (Figure 2C). Remarkably, this was similar to the hierarchy observed for HIV disease course (slower to faster): HHE/HHF*2 to HHE/HHE to HHE/HHG*2 (Figure 2D). Compared with persons who had HHE/HHF*2, those bearing HHE/HHG*2 had a nearly 4-fold (relative hazard, 4.70; 95% confidence interval [CI], 1.50–14.8; $P = .008$) faster rate of progression to AIDS (Figure 2D).

CCR5 Δ 32-Containing Genotypes and DTH/AIDS Status

We next evaluated the associations of *CCR5*- Δ 32 initially on the basis of the presence of the *CCR5*- Δ 32 (HHG*2) mutation (Figure 3A-B) and then at the level of specific Δ 32-containing genotypes (Figure 3C-F). The -2459G/G genotypes (HHA/HHA, HHC/HHC, or HHA/HHC) (Table 1) associated with higher DTH responses than did genotypes that contained the HHG*2 (Δ 32) haplotype (Figure 3A). In addition, HHG*2-containing genotypes did not associate with a slow disease course (Figure 3B). Because the HHE haplotype and HHE/HHE genotype associate with increased transcriptional activity [8] and accelerated disease course [7,13–15], respectively, we next determined whether the associations of HHG*2-containing genotypes differed depending on whether HHE comprised the partner haplotype. Although HHE/HHG*2 and the other HHG*2-containing genotypes had similar DTH responses (Figure 3C), HHE/HHG*2 associated with a markedly faster rate of disease course than did other HHG*2-containing genotypes (Figure 3D). The common Δ 32-containing genotypes, although associated with similar DTH responses (Figure 3E), associated with contrasting rates of disease progression, exhibiting a hierarchy of (slow to fast disease): HHC/HHG*2 to other HHG*2-containing genotypes to HHE/HHG*2 (Figure 3F).

CCR5 HHF*2-Bearing Genotypes with DTH and AIDS Status

Figure 2D shows that HHE/HHF*2 associated with a slow disease course, and Figure 4A shows that HHE/HHF*2 and -2459G/G-containing genotypes associated with comparably high DTH responses (Figure 4A) and similar disease courses (Figure 4B). Stratification of HHF*2-bearing genotypes revealed that although HHE/HHF*2 associated with significantly stronger DTH responses (Figure 4C), its association with a slower disease course did not reach statistical significance (Figure 4D).

Replication of A-2459G Genotypes Effects on DTH Status

CCR5 -2459G/G, G/A, and A/A genotypes associated with a step-wise decrease in DTH responses to PPD (Figure 5A), indicating that -2459G/G and -2459A/A associated with high and low DTH responses to both KLH (Figure 2A) and PPD (Figure 5A). Because of the consistent association of HHE/HHE with accelerated HIV disease course in multiple cohorts [7,13–15], we stratified -2459A/A-bearing genotypes into HHE/HHE versus all others (Figure 1 and Table 1). Figure 5B shows that -2459G/G-containing genotypes and HHE/HHE associate with the maximal and least DTH responses to PPD, respectively.

Table 1. Distribution of *CCR5* haplotype pairs (genotypes) among study participants

		HIV-infected children		HIV-uninfected adults	
		Ukraine	Argentina	Australia (DTH-KLH)	Colombia (DTH-PPD)
		Primary cohort	Replication cohort	Primary cohort	Replication cohort
G-2459A ^a	Haplotype pairs	No. (%)	No. (%)	No. (%)	No. (%)
G/G	HHA/HHC	13 (7.42)	15 (4.32)	21 (10.24)	5 (5.88)
	HHC/HHC	12 (6.85)	35 (10.09)	47 (22.92)	6 (7.05)
	HHA/HHA	4 (2.28)	1 (.29)	2 (.97)	1 (1.17)
	HHC/HHC	-	1 (.29)	-	1 (1.17)
	HHC/HHD	-	3 (.86)	-	3 (3.52)
	Total	29 (16.57)	55 (15.85)	70 (34.14)	16 (18.82)
G/A	HHC/HHE	24 (13.7)	92 (26.51)	40 (19.51)	19 (22.35)
	HHA/HHE	22 (12.5)	9 (2.59)	3 (1.46)	2 (2.35)
	HHC/HHF*2	11 (6.28)	30 (8.65)	15 (7.31)	7 (8.24)
	HHC/HHG*2	10 (5.71)	3 (.86)	9 (4.39)	-
	HHA/HHF*2	6 (3.42)	9 (2.59)	5 (2.43)	2 (2.35)
	HHA/HHG*2	6 (3.42)	2 (.58)	1 (.48)	-
	HHC/HHG*1	4 (2.28)	11 (3.17)	6 (2.97)	2 (2.35)
	HHA/HHG*1	1 (.57)	-	2 (.97)	-
	HHC/HHF*1	-	12 (3.46)	-	1 (1.17)
	HHD/HHF*2	-	3 (.86)	-	1 (1.17)
	HHD/HHE	-	1 (.29)	-	-
	HHA/HHF*1	-	2 (.58)	-	-
		Total	84 (48.00)	174 (50.14)	81 (39.51)
A/A	HHE/HHF*2	20 (11.4)	23 (6.63)	16 (7.80)	10 (11.76)
	HHE/HHE	14 (8.00)	41 (11.82)	16 (7.80)	6 (7.06)
	HHE/HHG*2	13 (7.42)	13 (3.75)	7 (3.41)	1 (1.17)
	HHE/HHG*1	5 (2.85)	14 (4.03)	2 (.97)	3 (3.53)
	HHF*2/HHF*2	4 (2.28)	8 (2.31)	5 (2.43)	6 (7.06)
	HHF*2/HHG*2	4 (2.28)	1 (.29)	3 (1.46)	1 (1.17)
	HHF*2/HHG*1	1 (.57)	4 (1.15)	1 (.48)	3 (3.53)
	HHG*1/HHG*1	1 (.57)	-	-	1 (1.17)
	HHG*1/HHG*2	-	4 (1.15)	1 (.48)	1 (1.17)
	HHF*1/HHF*2	-	-	1 (.48)	-
	HHG*2/HHG*2	-	-	2 (.97)	-
	HHE/HHF*1	-	8 (2.31)	-	2 (2.35)
	HHF*1/HHG*1	-	-	-	1 (1.17)
	HHF*1/HHG*2	-	2 (.58)	-	-
		Total	62 (35.42)	118 (34.01)	54 (26.34)
	Grand total	175	347	205	85

NOTE. DTH, delayed-type hypersensitivity; HH, human haplogroup; KLH, keyhole limpet hemocyanin; PPD, purified-protein derivative.

^a *CCR5* haplotype pairs (genotypes) based on the *CCR5* promoter polymorphism at position -2459 (Figure 1) are shown. The single nucleotide polymorphism (SNP) at -2135 is in 100% linkage with the SNP at the position -2459, such that -2459G is always linked with -2135T and -2459A is always linked with -2135C (Figure 1). Therefore, for simplicity, only the *CCR5* genotypes based on variations at position -2459 are shown.

Replication of A-2459G Genotypes Effects on AIDS

In HIV-infected Argentinean children, *CCR5* -2459G/G, G/A and A/A genotypes associated with a step-wise increase in the rate of disease progression, and consistent with the results shown in Figure 2B for HIV-infected Ukrainian children, -2459G/G- and -2459A/A-containing genotypes associated with maximal disease retardation and acceleration, respectively (Figure 6A). Also consistent with the results depicted in Figure 3B, in Argentinean children *CCR5*-Δ32 (HHG*2), heterozygosity associated with an accelerated disease course, compared with -2459G/G-containing genotypes (relative hazard, 1.69; 95% CI, .95 –

3.01; P: .073) (Figure 6B). Finally, mirroring the results shown in Figure 3F, in Argentinean children with *CCR5*-Δ32 heterozygosity, the accelerated disease course was also attributable mainly to HHE/HHG*2, because *CCR5*-Δ32 genotypes that were not HHE/HHG*2 associated with disease retardation (Figure 6C).

DISCUSSION

We identified specific *CCR5* SNPs and genotypes that associated with cutaneous DTH responses to 2 distinct antigens (KLH and

DTH responses to KLH in HIV negative Australian adults

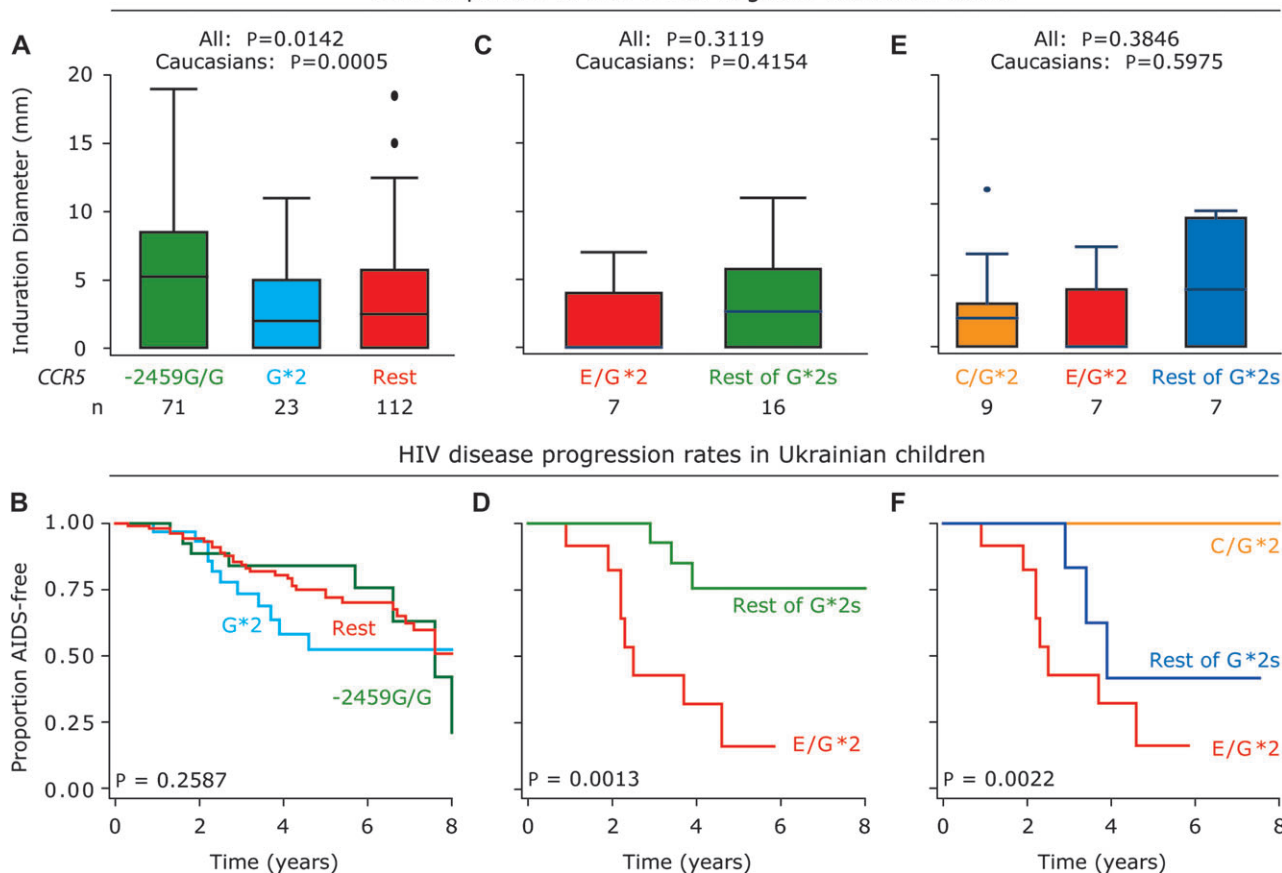

Figure 3. Association of *CCR5* HHG*2 ($\Delta 32$)-containing genotypes with DTH responses to KLH (A, C, E) and rate of progression to AIDS (B, D, F) for persons with the indicated *CCR5* genotypes. A, C, and E, Boxplots are for data from all Australian participants with the indicated genotypes. Significance values for all participants and the white persons in the Australian cohort are shown on the top. A and B, Comparisons are for participants bearing the $-2459G/G$ -containing genotypes (green), those bearing a *CCR5*- $\Delta 32$ -containing HHG*2 haplotype (designated as G*2; blue), and the remaining participants (designated as rest; red). C and D, Comparisons are for participants who possess a $\Delta 32$ -containing HHG*2 haplotype but differ according to whether the HHG*2 haplotype is paired with the HHE haplotype (E/G*2; red) or a non-HHE haplotype (denoted as rest of G*2s; green). E and F, Comparisons are for participants who possessed a $\Delta 32$ -containing HHG*2 haplotype but differed according to whether the HHG*2 haplotype was paired with the HHC haplotype (C/G*2; orange), the HHE haplotype (E/G*2; red), or a haplotype other than HHC or HHE (denoted as rest of G*2; blue). B, D, and F, P are log-rank or Wilcoxon significance values.

PPD) in healthy adults and clinical outcomes in 2 separate cohorts of HIV-infected children. Our results demonstrate a remarkable concordance in the *CCR5* genotypes that associated with DTH status in HIV-uninfected persons and those that associated with disease progression rates. In the primary Ukrainian cohort, $-2459G/G$ - (Figure 2B), HHE/HHF*2- (Figure 2D), and specific HHG*2 ($\Delta 32$)-containing genotypes (Figure 3F) associated with disease retardation, and apart from the $\Delta 32$ -containing genotypes, these genotypes also associated with increased DTH responses to KLH. By contrast, HHE/HHG*2 and HHE/HHE associated with lower DTH responses and a faster rate of disease progression in Ukrainian children. Results from the replication cohorts, underscored the beneficial impacts of $-2459G/G$ on both DTH and clinical outcomes (Figures 5 and 6). These results lend credence to the notion that *CCR5* may influence HIV

pathogenesis not only by impacting on parameters that are dependent on its coreceptor activity (eg, HIV entry and viral load), but also by influencing immune mechanisms (T cell immunity).

DTH responses are sensitive in vivo indicators of the ability to mount cell-mediated immune responses [1]. A distinctive aspect of this study was that, to minimize potential confounding due to variable prior exposure to these antigens, we applied the neo-antigen KLH to healthy, HIV-uninfected adults [25]. In a separate group of HIV-uninfected persons, we evaluated the DTH responses to the recall antigen PPD. Thus, the use of a neo-antigen is a strength of this study, and the results may further our understanding of the genetic determinants of CMI, a highly understudied area of research. Another strength of this study was that we evaluated 2 separate HIV-infected cohorts for the associations of *CCR5* genotype with AIDS progression rates and

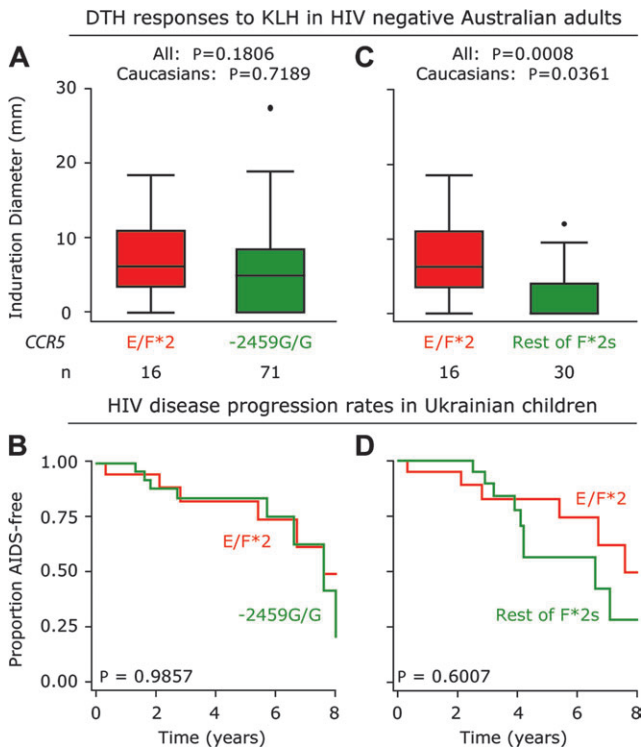

Figure 4. Association of HHF*2 (*CCR2*-64I)-containing genotypes with DTH responses to KLH (A, C) and rates of progression to AIDS (B, D). Boxplots are shown for data from all Australian participants with the indicated genotypes. A and B, Comparisons are for those possessing HHE/HHF*2 (E/F*2) versus 2459G/G-containing genotypes. C and D, Comparisons are for participants who possessed a *CCR2*-64I-containing HHF*2 haplotype but differed according to whether the HHF*2 haplotype was paired with the HHE haplotype (E/F*2; red) or a non-HHE haplotype (denoted as rest of F*2; green). A and C, Significance values for all participants and the white persons in the cohort are shown on the top. B and D, P reflects Wilcoxon significance values.

found, in general, concordant associations between *CCR5* genotype with both AIDS and DTH status.

We initiated our study by analyzing the association of *CCR5* -2459G/G, G/A, or A/A, because they have been scrutinized extensively for several HIV and non-HIV phenotypes [27–31]. This afforded the opportunity to place the results obtained herein the present study in the context of the following previously established genotype-phenotype correlations. First, reporter constructs bearing -2459G/-2135T (conflation of HHA to HHD) have lower transcriptional activity than do those bearing -2459A/-2135C (conflation of HHE to HHG) [8, 32]. Second, consistent with these transcriptional data, *CCR5* receptor density on CD4⁺ [9, 11] and CD14⁺ monocytes [10, 11, 33] is lower in cells bearing *CCR5* -2459G/G than in the G/A or A/A genotypes, with highest *CCR5* expression in cells bearing -2459A/A. Third, concordant with the latter 2 associations and consistent with the notion that *CCR5* levels correlate with susceptibility to R5 virus infection [18], peripheral blood mononuclear cells from healthy Caucasians bearing -2459G/G, A/G,

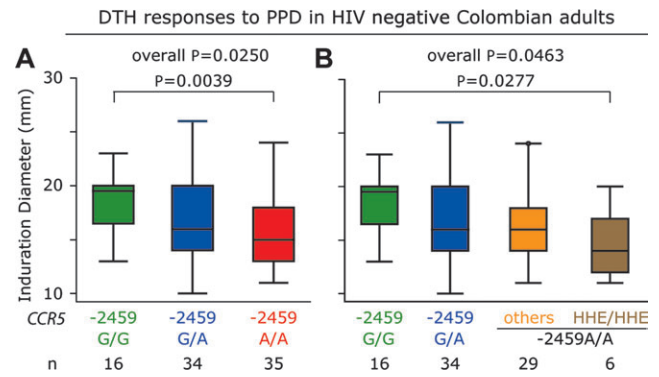

Figure 5. Association of genotypes containing *CCR5* -2459G/G, G/A, and A/A with DTH responses to purified-protein derivative (PPD) in HIV-uninfected Colombians. This cohort represents a replication cohort to assess the associations of DTH responses with *CCR5* genotypes. Only participants with an induration of >10 mm after application of PPD were included in the analyses. A, Boxplots depicting DTH responses to PPD in participants with genotypes containing *CCR5* -2459G/G (green), -2459G/A (blue), and -2459A/A (red). B, Participants bearing -2459A/A were further stratified into those -2459A/A genotypes that are classified as HHE/HHE versus those -2459A/A genotypes that are not HHE/HHE (designated as others; Table 1).

and A/A genotypes, respectively, associate with low, medium, and high R5 viral propagation in vitro [10]. A concordant hierarchy of R5 viral susceptibility was found after ex vivo infection of Langerhans cells bearing -2459G/G, A/G, and A/A genotypes [12]. Fourth, -2459G/G-containing genotypes consistently associate with mitigated HIV and AIDS susceptibility [7, 32, 34].

Consistent with the salutary associations for -2459G/G-containing genotypes (reduced *CCR5* transcriptional activity/surface expression, viral replication, and HIV and AIDS susceptibility), we found that these genotypes associated not only with HIV disease retardation but also enhanced DTH responses in 2 HIV-uninfected cohorts. However, because of the differential distributions of *CCR5* haplotypes across different human populations [22], the associations of -2459G/G-containing genotypes are likely to differ according to the ethnic/racial background of the cohorts studied [7, 14].

After establishing the associations at the level of the -2459 (and linked -2135) SNP, we next identified the specific *CCR5* haplotype pairs that influence DTH and AIDS status. The associations for the *CCR5* haplotype pairs for HIV disease in the 2 pediatric cohorts are consistent with those reported previously in adult HIV cohorts, and remarkably, in most instances, concordant associations for these haplotype pairs were also observed for DTH.

The data presented here, together with aforementioned published data, affirm that the disease-retarding effects of *CCR5*- Δ 32 heterozygosity may be attributable mainly to 3 Δ 32-containing HHG*2 genotypes (HHA/HHG*2, HHC/HHG*2, and HHF*2/HHG*2), whereas HHE/HHG*2 is associated with

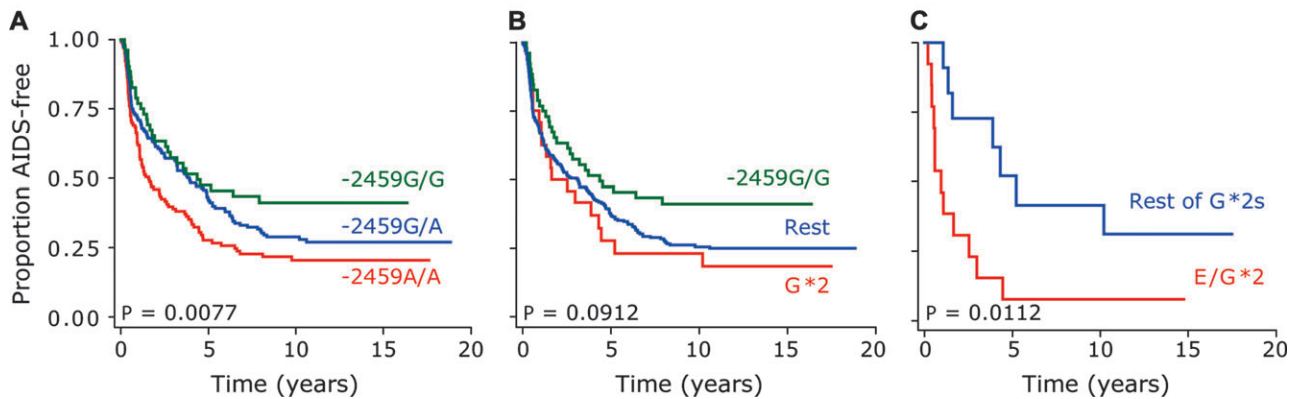

Figure 6. Replication of the associations of *CCR5* G-2459A genotypes with progression to AIDS in a cohort of HIV-infected children from Argentina. Kaplan-Meier plots for the association of the following *CCR5* genotypes with rate of disease progression to AIDS: genotypes containing A, *CCR5* –2459G/G (green), –2459G/A (blue), and –2459A/A (red); B, –2459G/G-containing genotypes (green), HHG*2-containing genotypes (G*2; red), and all other genotypes (designated as rest; blue); and C, Δ 32-containing genotypes that contain HHE (E/G*2; red) versus all other Δ 32-containing genotypes (designated as rest of G*2; blue). P, log-rank significance values.

detrimental effects. Of interest, the differentiating feature of these protective versus detrimental *CCR5*- Δ 32-containing genotypes is whether the partner non- Δ 32 haplotype is HHE. These contrasting associations of specific Δ 32-containing genotypes should not be unexpected, because the functional burden is placed entirely on the partner haplotype. The lower DTH responses to KLH associated with the *CCR5*- Δ 32 mutation is consistent with the impaired responses to KLH in *CCR5* knockout mice [4], and we surmise that this may relate to reduced leukocyte chemotaxis associated with this genotype [35].

The associations of HHE-containing genotypes also underscore the importance of accounting for both *CCR5* haplotypes when conducting genotype-phenotype studies. Consistent with prior reports [7, 13, 15], HHE/HHE associated with disease acceleration in Ukrainian children, and we showed that it also associates with reduced DTH responses to both KLH and PPD. However, the association of HHE heterozygosity depends on the partner allele, as exemplified by the observation that HHE/HHF*2 (*CCR2*-64I) and HHE/HHG*2 (Δ 32), respectively, associated with higher versus lower CMI status and with slow versus rapid disease progression.

CCR5 expression levels impact many different facets of HIV pathogenesis, namely HIV entry [18, 19], HIV acquisition [7, 11, 19, 36], AIDS progression rates [37], viral load [37], immune reconstitution during highly active antiretroviral therapy [37–39], efficacy of *CCR5* blockers and entry inhibitors [40], and neutralizing activity of HIV-1-specific antibodies [41]. Remarkably, in each instance, low *CCR5* surface expression is associated with a protective phenotype. The prevailing viewpoint links the beneficial effects of lower *CCR5* expression to reduced coreceptor activity of *CCR5*. However, we propose that *CCR5* may also influence HIV pathogenesis by immune-based mechanisms independent of its function as a coreceptor. Support for

this thesis comes from several sources. First, extensive data now indicate an important role for the *CCR5*-*CCR5* ligand system in T cell immunity, including formation of the immunological synapse, T cell differentiation, proliferation, and activation-induced cell death (discussed in [4, 17]). Relevant to this study, *CCR5* expression associates with Th1 responses, as do DTH responses [1]. Second, nonhuman primates with simian immunodeficiency virus (SIV) infection that do not progress to AIDS (eg, Sooty Mangabey) display low *CCR5* levels, despite high-level viremia [42], suggesting that the low *CCR5* expression may confer a protective effect by impacting on functions other than viral entry, one of which we propose may be CMI status. Of note, on the basis of its close homology to chimpanzee *CCR5* sequence, HHA/HHA represents the ancestral genotype [8] and is among the –2459G/G-containing genotypes that associated with increased CMI status. In a previous study, we suggested that this ancestral genotype may help to explain the partial resistance to SIV disease progression in chimpanzee and the reduced acquisition of SIV in some human populations that have a long history of cohabitation with chimpanzees (eg, Pygmy) [14]. The association of *CCR5* HHA/HHA with increased CMI lends further credence to this possibility. Third, the *CCR5*-null state or antagonism of *CCR5* is associated with reduced inflammation and transplant rejection [17, 43, 44]. Furthermore, the importance of *CCR5*-associated CMI status is underscored by the observation that –2459G/G-containing genotypes correlate with salutary effects in multiple other diseases in which the HIV-1 coreceptor activity of *CCR5* is irrelevant [27–31].

Of note, *CCR5* expression is correlated with T cell activation levels [20, 45], and preseroconversion activation status predicts both risk of infection and disease progression rates [46–50]. In addition, preseroconversion *CCR5* expression levels are a determinant of disease progression [20]. Together, these

observations raise the possibility that *CCR5* genotypes influence pre-infection status of CMI or other relevant immune phenotypes (eg, T cell activation) that may alter both risk of infection and AIDS progression rates.

In summary, we found a high degree of concordance between the associations of *CCR5* genotypes that influence DTH status and those that influence *CCR5* transcriptional activity and/or surface expression, viral replication, and HIV and AIDS susceptibility. These data support 2 related conclusions. First, they indicate a genetically determined relationship among reduced *CCR5* expression, increased CMI responses, reduced HIV replication, and disease retardation. Second, *CCR5* may affect HIV and AIDS susceptibility by influencing 2 different mechanisms: 1) viral entry and/or replication and 2) CMI.

Funding

This work was supported by the US Civilian Research and Development Foundation (UKB1-2931-DN-08 to L.S.-K.), the Veterans Administration Center on AIDS and HIV infection of the South Texas Veterans Health Care System, and the National Institutes of Health (R37-AI046326 and R01-AI043279 to S.K.A.). S.K.A. is also supported by a VA MERIT award and is a recipient of the Elizabeth Glaser Scientist Award, the Burroughs Wellcome Clinical Scientist Award in Translational Research, and the Doris Duke Distinguished Clinical Scientist Award.

Acknowledgments

We thank the staff members and patients at the Department of Pediatrics at Dnepropetrovsk State Medical Academy, for their support of this work, and Birju Shah, Vivian Ahn, and Enrique Gonzalez for assistance in *CCR5* genotyping. Because of journal limits on references, we have included only representative references, and a more complete list of references is available from the authors. We regret our inability to cite other excellent work done in this field.

References

- Kobayashi K, Kaneda K, Kasama T. Immunopathogenesis of delayed-type hypersensitivity. *Microsc Res Tech* **2001**; 53:241–5.
- Dolan MJ, Clerici M, Blatt SP, et al. In vitro T cell function, delayed-type hypersensitivity skin testing, and CD4+ T cell subset phenotyping independently predict survival time in patients infected with human immunodeficiency virus. *J Infect Dis* **1995**; 172:79–87.
- Maas JJ, Roos MT, Keet IP, et al. In vivo delayed-type hypersensitivity skin test anergy in human immunodeficiency virus type 1 infection is associated with T cell nonresponsiveness in vitro. *J Infect Dis* **1998**; 178:1024–9.
- Dolan MJ, Kulkarni H, Camargo JF, et al. CCL3L1 and *CCR5* influence cell-mediated immunity and affect HIV-AIDS pathogenesis via viral entry-independent mechanisms. *Nat Immunol* **2007**; 8:1324–36.
- Anastos K, Shi Q, French AL, et al. Total lymphocyte count, hemoglobin, and delayed-type hypersensitivity as predictors of death and AIDS illness in HIV-1-infected women receiving highly active antiretroviral therapy. *J Acquir Immune Defic Syndr* **2004**; 35:383–92.
- Valdez H, Smith KY, Landay A, et al. Response to immunization with recall and neoantigens after prolonged administration of an HIV-1 protease inhibitor-containing regimen. ACTG 375 team. *AIDS Clinical Trials Group. AIDS* **2000**; 14:11–21.
- Kaslow RA, Dorak T, Tang JJ. Influence of host genetic variation on susceptibility to HIV type 1 infection. *J Infect Dis* **2005**; 191:568–77.
- Mummidi S, Bamshad M, Ahuja SS, et al. Evolution of human and non-human primate CC chemokine receptor 5 gene and mRNA. Potential roles for haplotype and mRNA diversity, differential haplotype-specific transcriptional activity, and altered transcription factor binding to polymorphic nucleotides in the pathogenesis of HIV-1 and simian immunodeficiency virus. *J Biol Chem* **2000**; 275:18946–61.
- Shieh B, Liao YE, Hsieh PS, Yan YP, Wang ST, Li C. Influence of nucleotide polymorphisms in the *CCR2* gene and the *CCR5* promoter on the expression of cell surface *CCR5* and *CXCR4*. *Int Immunol* **2000**; 12:1311–8.
- Salkowitz JR, Bruse SE, Meyerson H, et al. *CCR5* promoter polymorphism determines macrophage *CCR5* density and magnitude of HIV-1 propagation in vitro. *Clin Immunol* **2003**; 108:234–40.
- Thomas SM, Tse DB, Ketner DS, et al. *CCR5* expression and duration of high risk sexual activity among HIV-seronegative men who have sex with men. *AIDS* **2006**; 20:1879–83.
- Kawamura T, Gulden FO, Sugaya M, et al. R5 HIV productively infects Langerhans cells, and infection levels are regulated by compound *CCR5* polymorphisms. *Proc Natl Acad Sci U S A* **2003**; 100:8401–6.
- Martin MP, Dean M, Smith MW, et al. Genetic acceleration of AIDS progression by a promoter variant of *CCR5*. *Science* **1998**; 282:1907–11.
- Gonzalez E, Bamshad M, Sato N, et al. Race-specific HIV-1 disease-modifying effects associated with *CCR5* haplotypes. *Proc Natl Acad Sci U S A* **1999**; 96:12004–9.
- Mangano A, Gonzalez E, Dhanda R, et al. Concordance between the CC chemokine receptor 5 genetic determinants that alter risks of transmission and disease progression in children exposed perinatally to human immunodeficiency virus. *J Infect Dis* **2001**; 183:1574–85.
- Loetscher P, Ugucioni M, Bordoli L, et al. *CCR5* is characteristic of Th1 lymphocytes. *Nature* **1998**; 391:344–5.
- Camargo JF, Quinones MP, Mummidi S, et al. *CCR5* expression levels influence NFAT translocation, IL-2 production, and subsequent signaling events during T lymphocyte activation. *J Immunol* **2009**; 182:171–82.
- Wu L, Paxton WA, Kassam N, et al. *CCR5* levels and expression pattern correlate with infectability by macrophage-tropic HIV-1, in vitro. *J Exp Med* **1997**; 185:1681–91.
- Paxton WA, Liu R, Kang S, et al. Reduced HIV-1 infectability of CD4+ lymphocytes from exposed-uninfected individuals: association with low expression of *CCR5* and high production of beta-chemokines. *Virology* **1998**; 244:66–73.
- de Roda Husman AM, Blaak H, Brouwer M, Schuitemaker H. CC chemokine receptor 5 cell-surface expression in relation to CC chemokine receptor 5 genotype and the clinical course of HIV-1 infection. *J Immunol* **1999**; 163:4597–603.
- Paxton WA, Kang S, Liu R, et al. HIV-1 infectability of CD4+ lymphocytes with relation to beta-chemokines and the *CCR5* coreceptor. *Immunol Lett* **1999**; 66:71–5.
- Gonzalez E, Dhanda R, Bamshad M, et al. Global survey of genetic variation in *CCR5*, *RANTES*, and *MIP-1alpha*: impact on the epidemiology of the HIV-1 pandemic. *Proc Natl Acad Sci U S A* **2001**; 98:5199–204.
- Tang J, Shelton B, Makhatadze NJ, et al. Distribution of chemokine receptor *CCR2* and *CCR5* genotypes and their relative contribution to human immunodeficiency virus type 1 (HIV-1) seroconversion, early HIV-1 RNA concentration in plasma, and later disease progression. *J Virol* **2002**; 76:662–72.
- Hladik F, Liu H, Speelman E, et al. Combined effect of *CCR5*-Delta32 heterozygosity and the *CCR5* promoter polymorphism -2459 A/G on *CCR5* expression and resistance to human immunodeficiency virus type 1 transmission. *J Virol* **2005**; 79:11677–84.
- Smith A, Vollmer-Conna U, Geczy A, et al. Does genotype mask the relationship between psychological factors and immune function? *Brain Behav Immun* **2005**; 19:147–52.

26. Shostakovich-Koretskaya L, Catano G, Chykarenko ZA, et al. Combinatorial content of CCL3L and CCL4L gene copy numbers influence HIV-AIDS susceptibility in Ukrainian children. *AIDS* **2009**; 23: 679–88.
27. Ahn SH, Kim do Y, Chang HY, et al. Association of genetic variations in CCR5 and its ligand, RANTES with clearance of hepatitis B virus in Korea. *J Med Virol* **2006**; 78:1564–71.
28. Thio CL, Astemborski J, Bashirova A, et al. Genetic protection against hepatitis B virus conferred by CCR5Delta32: Evidence that CCR5 contributes to viral persistence. *J Virol* **2007**; 81:441–5.
29. Konishi I, Horiike N, Hiasa Y, Michitaka K, Onji M. CCR5 promoter polymorphism influences the interferon response of patients with chronic hepatitis C in Japan. *Intervirology* **2004**; 47:114–20.
30. Mokubo A, Tanaka Y, Nakajima K, et al. Chemotactic cytokine receptor 5 (CCR5) gene promoter polymorphism (59029A/G) is associated with diabetic nephropathy in Japanese patients with type 2 diabetes: a 10-year longitudinal study. *Diabetes Res Clin Pract* **2006**; 73:89–94.
31. Cha RH, Yang SH, Kim HS, et al. Genetic interactions between the donor and the recipient for susceptibility to acute rejection in kidney transplantation: polymorphisms of CCR5. *Nephrol Dial Transpl* **2009**; 24:2919–25.
32. McDermott DH, Zimmerman PA, Guignard F, Kleeberger CA, Leitman SF, Murphy PM. CCR5 promoter polymorphism and HIV-1 disease progression. Multicenter AIDS Cohort Study (MACS). *Lancet* **1998**; 352:866–70.
33. Sellebjerg F, Kristiansen TB, Wittenhagen P, et al. Chemokine receptor CCR5 in interferon-treated multiple sclerosis. *Acta Neurol Scand* **2007**; 115:413–8.
34. Pedersen BR, Kamwendo D, Blood M, et al. CCR5 haplotypes and mother-to-child HIV transmission in Malawi. *LoS One* **2007**; 2:e838.
35. Panzer U, Schneider A, Steinmetz OM, et al. The chemokine receptor 5 Delta32 mutation is associated with increased renal survival in patients with IgA nephropathy. *Kidney Int* **2005**; 67:75–81.
36. Reynes J, Baillat V, Portales P, Clot J, Corbeau P. Low CD4+ T-cell surface CCR5 density as a cause of resistance to in vivo HIV-1 infection. *J Acquir Immune Defic Syndr* **2003**; 34:114–6.
37. Gervais A, Nicolas J, Portales P, et al. Response to treatment and disease progression linked to CD4+ T cell surface CC chemokine receptor 5 density in human immunodeficiency virus type 1 vertical infection. *J Infect Dis* **2002**; 185:1055–61.
38. Vincent T, Portales P, Baillat V, et al. The immunological response to highly active antiretroviral therapy is linked to CD4+ T-cell surface CCR5 density. *J Acquir Immune Defic Syndr* **2006**; 43:377–8.
39. Reynes J, Baillat V, Portales P, Clot J, Corbeau P. Relationship between CCR5 density and viral load after discontinuation of antiretroviral therapy. *JAMA* **2004**; 291:46.
40. Heredia A, Gilliam B, DeVico A, et al. CCR5 density levels on primary CD4 T cells impact the replication and Enfuvirtide susceptibility of R5 HIV-1. *AIDS* **2007**; 21:1317–22.
41. Choudhry V, Zhang MY, Harris I, et al. Increased efficacy of HIV-1 neutralization by antibodies at low CCR5 surface concentration. *Biochem Biophys Res Commun* **2006**; 348:1107–15.
42. Pandrea I, Apetrei C, Gordon S, et al. Paucity of CD4+CCR5+ T cells is a typical feature of natural SIV hosts. *Blood* **2007**; 109:1069–76.
43. Schroder C, Pierson RN 3rd, Nguyen BN, et al. CCR5 blockade modulates inflammation and alloimmunity in primates. *J Immunol* **2007**; 179:2289–99.
44. Fischereder M, Luckow B, Hoher B, et al. CC chemokine receptor 5 and renal-transplant survival. *Lancet* **2001**; 357:1758–61.
45. Smith KY, Kumar S, Pulvirenti JJ, Ganesin M, Kessler HA, Landay A. CCR5 and CXCR4 expression after highly active antiretroviral therapy (HAART). *J Acquir Immune Defic Syndr* **2002**; 30:458–60.
46. Koning FA, Otto SA, Hazenberg MD, et al. Low-level CD4+ T cell activation is associated with low susceptibility to HIV-1 infection. *J Immunol* **2005**; 175:6117–22.
47. van Asten L, Danisman F, Otto SA, et al. Pre-seroconversion immune status predicts the rate of CD4 T cell decline following HIV infection. *Aids* **2004**; 18:1885–93.
48. Hazenberg MD, Otto SA, van Benthem BH, et al. Persistent immune activation in HIV-1 infection is associated with progression to AIDS. *AIDS* **2003**; 17:1881–8.
49. Miyazawa M, Lopalco L, Mazzotta F, Lo Caputo S, Veas F, Clerici M. The 'immunologic advantage' of HIV-exposed seronegative individuals. *AIDS* **2009**; 23:161–75.
50. Begaud E, Chartier L, Marechal V, et al. Reduced CD4 T cell activation and in vitro susceptibility to HIV-1 infection in exposed uninfected Central Africans. *Retrovirology* **2006**; 3:35.