



Non-chromatographic screening method for the determination of mercury species. Application to the monitoring of mercury levels in Antarctic samples

Pablo H. Pacheco^{a,b}, Adrián Spisso^a, Soledad Cerutti^{a,b}, Patricia Smichowski^{c,d,**}, Luis D. Martinez^{a,b,*}

^a Departamento de Química Analítica, Facultad de Química, Bioquímica y Farmacia, Universidad Nacional de San Luis, Chacabuco y Pedernera, P.O. Box 375, CP 5700 San Luis, Argentina

^b Instituto de Química de San Luis (INQUISAL-CONICET), Chacabuco y Pedernera, CP 5700 San Luis, Argentina

^c Consejo Nacional de Investigaciones Científicas y Técnicas (CONICET), Rivadavia 1917, CP C1033 AAJ Ciudad de Buenos Aires, Argentina

^d Comisión Nacional de Energía Atómica, Gerencia Química, Av. Gral. Paz 1499, B1650KNA-San Martín, Argentina

ARTICLE INFO

Article history:

Received 10 June 2010

Received in revised form 13 July 2010

Accepted 15 July 2010

Available online 22 July 2010

Keywords:

Screening method

Mercury species

Adamussium colbecki

Antarctic Krill

ABSTRACT

A simple non-chromatographic method for the determination of mercury (Hg^{2+}), methylmercury (MeHg^+), dimethylmercury (Me_2Hg), and phenylmercury (PhHg^+) employing atomic fluorescence spectrometry (AFS) as detection technique was developed. Mercury species showed a particular behavior in the presence of several reagents. In a first stage SnCl_2 was employed for Hg^{2+} determination; in a second step, $[\text{Hg}^{2+} + \text{PhHg}^+]$ concentration was determined using SnCl_2 and UV radiation. MeHg^+ decomposition was prevented adding 2-mercaptoethanol. In a third stage, $[\text{Hg}^{2+} + \text{PhHg}^+ + \text{MeHg}^+]$ concentration was determined using $\text{K}_2\text{S}_2\text{O}_8$. Finally, the four species were determined employing NaBH_4 . Reagents concentration and flow rates were optimized. The extraction technique of mercury species involved the use of 2-mercaptoethanol as ion-pair reagent. The limits of detection for Hg^{2+} , PhHg^+ , MeHg^+ , and Me_2Hg were 1, 40, 68, and 99 ng L^{-1} with a relative standard deviation of 1.5, 3.1, 4.7 and 5.8%, respectively. Calibration curve was linear with a correlation factor equal to 0.9995. The method was successfully applied to the determination of the mercury species in two Antarctic materials: IRMM 813 (*Adamussium colbecki*) and MURST-ISS-A2 (Antarctic Krill).

© 2010 Elsevier B.V. All rights reserved.

1. Introduction

Public health reasons and the fact that mercury is a highly toxic element that is found both naturally and as an introduced contaminant in the environment have increased the interest on its speciation analysis in a variety of biological, industrial, and food samples. The toxicity of mercury depends on its concentration and chemical form [1,2]. Mercury occurs principally in three different chemical species: elemental, inorganic, and organic forms such as monomethylmercury (CH_3Hg , hereafter referred to as “ MeHg^+ ”) and dimethylmercury [$(\text{CH}_3)_2\text{Hg}$, hereafter referred to as “ Me_2Hg ”] [3,4]. Within these above-named forms, organic mercury species are more toxic than the others [4,5]. Therefore, it is important to determine inorganic and organic species instead of total mercury.

Mercury species may induce alterations in the normal development of the brain of infants and may induce neurological changes in adults [6]. MeHg^+ is a known neurotoxin causing reproductive, immunosuppressive, neurobehavioral risks to biota [7] and the Minamata disease in humans [8]. It is produced mainly by microbial methylation of inorganic mercury (Hg) in the aquatic environment [9] and is one of the most common contaminants in fish and marine mammals due to its biomagnifications along the food chain [10].

Environmental monitoring in Antarctica plays a key role for assessing ongoing pollution phenomena on a planetary scale in order to preserve as much as possible the pristine conditions in this ecosystem [11–13]. Antarctic ecosystems have unique characteristics resulting from their distances from continents with high populations. Anthropogenic contamination is negligible because there is no human impact due to any significant human work activities. Mercury is emitted to the atmosphere mainly as vapor by natural or anthropogenic sources and it is the only metal that biomagnifies through food chains [14]. The relative long residence time in the atmosphere (circa 1 year) and consequent long-range transport, together with natural transformation into methylmercury, make exposure of target organisms to mercury, potentially serious, even in remote areas [15].

Antarctic Krill (Fig. 1) are a small planktonic crustaceans primarily present in the southern ocean, with a total biomass estimated

* Corresponding author at: Instituto de Química de San Luis (INQUISAL-CONICET), Chacabuco y Pedernera, CP 5700 San Luis, Argentina. Fax: +54 2652 430224.

** Corresponding author at: Consejo Nacional de Investigaciones Científicas y Técnicas (CONICET), Rivadavia 1917, CP C1033 AAJ Ciudad de Buenos Aires, Argentina. Fax: +54 11 6772 7886.

E-mail addresses: smichows@cnea.gov.ar (P. Smichowski), ldm@unsl.edu.ar (L.D. Martinez).

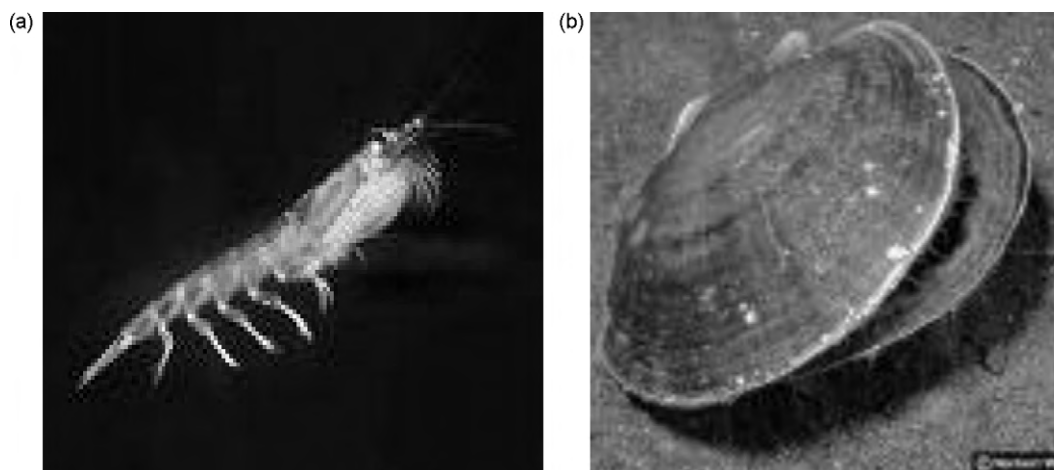

Fig. 1. (a) Antarctic Krill and (b) *Adamussium colbecki*.

to be around 600 billion individuals migrating in large groups over long distances [16]. *Adamussium colbecki* (Fig. 1) is an endemic Antarctic scallop, abundant in near shore waters, with the ability to accumulate contaminants [11]. These organisms take up and accumulate metals in great quantities in soft tissues, offering some advantages in the analysis of abiotic matrices. As a consequence, these organisms can be employed for the evaluation and assessment of pollution in marine coastal environments. In addition, they only accumulate the biologically available form of the pollutant [17]. Therefore, the determination of Hg species in biota collected in Antarctica is of prime importance to gain knowledge on levels of pollutants in pristine areas.

Quantification of mercury species normally requires the use of hyphenated techniques, involving a more complex instrumentation in comparison with that needed for single element measurements [18]. These systems are based on the use of highly efficient separation techniques such as gas chromatography (GC), high performance liquid chromatography (HPLC) or capillary electrophoresis (CE) coupled to sensitive and selective atomic spectrometric detectors, such as atomic absorption spectrometry (AAS) [19], atomic fluorescence spectrometry (AFS) [20], inductively coupled plasma mass spectrometry (ICP-MS) [21], inductively coupled plasma optical emission spectrometry (ICP-OES) [22], and microwave-induced plasma optical emission spectrometry (MIP-OES) [23]. Although these hyphenated methods are attractive for mercury speciation due to their excellent detection limits and selectivity, high instrumental and operational costs make them difficult to use in routine analysis or in laboratories with limited instrumentation.

Cold vapor atomic fluorescence spectrometry (CV-AFS) is a well known and widely used technique for mercury determination. Generation of a cold vapor from organo mercury species requires a step to achieve their conversion to Hg(II). Mercury speciation analysis was done by CV-AFS without chromatographic separations. The discrimination between inorganic mercury and total mercury was based on the differential behavior of mercury species with several reducing agents [24,25]. This conversion has been usually performed online and has been facilitated using a number of different approaches such as oxidation with potassium persulfate [23,26,27]. Although the chemical oxidation can be achieved at room temperature, the reaction time for an efficient conversion can be long. The use of UV irradiation is a valid alternative to facilitate the decomposition of mercury species [28–30].

In this study, a non-chromatographic method for the determination of Hg^{2+} , MeHg^+ , Me_2Hg , and PhHg^+ is presented. The determination is based on the singular behavior of mercury species

versus the different reagents/approaches involved in the cold vapor generation such as sodium borohydride, stannous chloride, potassium persulfate, and UV radiation. The proposed method was applied to the determination of mercury species in the candidate certified reference material IRMM 813 *A. colbecki*, and compared to the mercury content in CRM MURST-ISS-A2 Antarctic Krill. In order to extract the mercury species, 2-mercaptoethanol in acidic media was employed. The extraction efficiency was compared with a microwave-assisted digestion technique and the certified value (MURST-ISS-A2) reported for total Hg. To the best of our knowledge, this is the first time that four mercury species are determined employing a non-chromatographic methodology.

2. Experimental

2.1. Instrumentation

Mercury fluorescence measurements were carried out with an atomic fluorescence spectrometer, AI 3300, Aurora Instruments (Vancouver, British Columbia, Canada). The apparatus was equipped with a two-channel peristaltic pump for the continuous fluorescence measurements. A mercury hollow cathode lamp from Aurora Instruments (Vancouver, British Columbia, Canada) was employed as Hg fluorescence excitation source. The flow injection (FI) system used is shown in Fig. 2. Samples and solvents were delivered by a Minipulse 3 peristaltic pump Gilson (Villiers-Le-Bell, France). UV decomposition was achieved with a 400 W Hg vapor lamp (15 W G15T8 UV-C LONG LIFE high pressure Hg, PHILIPS) that ignited with a suitable starter and chock and surrounded by a 3-m PTFE tubing.

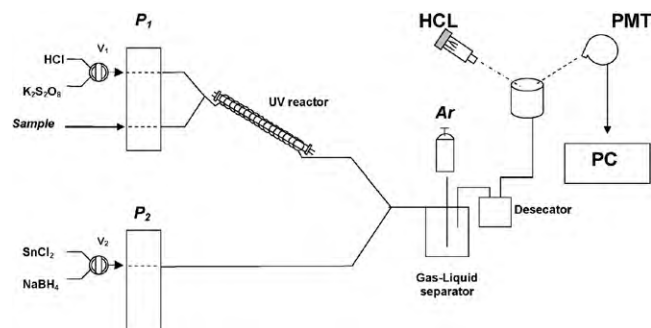

Fig. 2. Schematic diagram of the instrumental set-up. V₁, valve 1; V₂, valve 2; P₁, pump 1; P₂, pump 2; HCL, hollow cathode lamp; PMT, photomultiplier tube.

Microwave digestion was performed with a Milestone Start D microwave system (Soriso, Italy), and with Milestone hermetically sealed 1 cm wall thickness polytetrafluoroethylene reactors (100 mL internal volume).

2.2. Reagents

Unless otherwise stated, the chemicals used were of analytical grade and thus required no further purification. Ultrapure water ($18\text{ m}\Omega\text{ cm}^{-1}$) was obtained from EASY pure (RF Barnstedt, IA, USA). Inorganic mercury stock solution of 1000 mg L^{-1} was prepared by dissolving mercury chloride from Merck (Darmstadt, Germany) in ultrapure water. The stock solutions of 1000 mg L^{-1} (as Hg) of methylmercury (MeHg^+), dimethylmercury (Me_2Hg), and phenylmercury (PhHg^+) were prepared by dissolving the salts from Merck (Darmstadt, Germany) of methylmercury chloride and phenylmercury chloride; and dimethylmercury as well, in methanol. Working solutions were prepared from the stock solutions by stepwise dilution.

A $\text{SnCl}_2 \cdot 2\text{H}_2\text{O}$ salt from Sigma (St. Louis, MO, USA) in 10% (v v^{-1}) HCl (Merck) was used as reductant agent. It was prepared by dissolving the salt in concentrated HCl, heating for 10 min, and diluting with water. NaBH_4 from Sigma (Stenheim, Germany) was prepared in a 0.5% (m v^{-1}) sodium hydroxide solution. Potassium persulfate (99%) obtained from Fluka AG (Switzerland) was diluted in 40% (v v^{-1}) HCl solution. 2-Mercaptoethanol from Merck (Darmstadt, Germany) was prepared by dilution in ultrapure water.

Two certified reference materials (CRMs) MURST-ISS-A2 (*Antarctic Krill*) and IRMM 813 (*A. colbecki*) were used for the validation procedure.

2.3. Sample preparation

The quantitative extraction of mercury species from biological samples was achieved using 0.1% (v v^{-1}) HCl, 0.1% (v v^{-1}) 2-mercaptoethanol, and 0.15% (m v^{-1}) KCl extractant solution, as recommended by Wang et al. [31]. The extraction procedure employed for the determination of the mercury species was applied as follows: 0.5 g portions of the reference materials were weighed into 4 mL vials. Then, 4 mL of the extractant solution were added. Subsequently, the mixture solutions were put into an incubator for overnight shaking (about 12 h) at room temperature. Afterwards, the supernatant was collected and employed for measurements directly.

The microwave digestion for total mercury determination was performed as follows: 0.2 g portions of the reference material were weighed and placed in individual microwave graduated polystyrene tubes. The aliquots were treated with 8 mL of $\text{HNO}_3 + \text{H}_2\text{O}_2$ (3:1, v v^{-1}) [11]. Dissolution was carried out at a pressure between 10 and 20 bars, at increasing power from 250 to 600 W.

2.4. Procedure

The FI system used for Hg species extraction/determination is shown in Fig. 2. The sequence employed involved several stages as follows: in a first stage SnCl_2 was employed for Hg^{2+} determination (valve V_1 in position HCl, valve V_2 in position SnCl_2), without UV radiation. In a second stage, ($\text{Hg}^{2+} + \text{PhHg}^+$) concentration was determined using SnCl_2 and applying UV radiation. MeHg^+ decomposition was prevented by the addition of 0.1% (v v^{-1}) 2-mercaptoethanol. In a third stage, ($\text{Hg}^{2+} + \text{PhHg}^+ + \text{MeHg}^+$) concentration was determined by changing valve V_2 to $\text{K}_2\text{S}_2\text{O}_8$ position, using UV radiation. Finally, and in order to reach the decomposition of the four mercury species (Hg^{2+} , PhHg^+ , MeHg^+ and Me_2Hg), valve V_2 was changed to NaBH_4 position (Table 1 shows the experimental conditions).

Table 1
Experimental conditions for the FI-UV-CV-AFS system.

Parameter	Optimized value
CV generation	
Sample flow rate	1 mL min^{-1}
NaBH_4 reagent	0.5% (m v^{-1}) in 0.5% NaOH
NaBH_4 flow rate	2 mL min^{-1}
SnCl_2 reagent	10% (m v^{-1}) in 30% (v v^{-1}) HCl
SnCl_2 flow rate	2 mL min^{-1}
HCl reagent	30% (v v^{-1})
HCl flow rate	1 mL min^{-1}
Oxidation	
$\text{K}_2\text{S}_2\text{O}_8$ reagent	1% (m v^{-1}) in 30% (v v^{-1}) HCl
$\text{K}_2\text{S}_2\text{O}_8$ flow rate	1 mL min^{-1}
Power of UV lamp	15 W
Digestion coil	3 m
Digestion coil i.d.	0.8 mm
AFS	
Lamp	Mercury hollow cathode lamp, 253.7 nm
PMT voltage	300 V
Primary current	35 mA
Carrier gas	Ar, 200 mL min^{-1}

3. Results and discussion

3.1. Evaluation of reagents flow rate

Reagents flow rate is an important parameter to optimize since this is one of the parameters that affects the time of analysis. The optimized flow rates are shown in Table 1. It was verified that these flow rates reduced the noise and fluctuations on mercury signal, reaching more stabilized mercury lectures. In addition, these flow rates reduced reagent consumption.

3.2. Evaluation of reagents concentrations

All reagents concentrations involved in the determination of mercury species were evaluated and the optimal values are reported in Table 1. In addition, other inorganic acids such as HNO_3 were also evaluated and no significant difference on mercury signal was observed.

3.2.1. Evaluation of 2-mercaptoethanol concentration

2-Mercaptoethanol reagent has two important roles in the determination of mercury species. Firstly, it is used as extractant during sample preparation and secondly, it prevents MeHg^+ decomposition by UV radiation differentiating MeHg^+ signal from Hg^{2+} and PhHg^+ signals.

As stated by Wang et al. [31], 2-mercaptoethanol can be used as an ion-pair reagent in extractant solutions. Chemically, Hg^{2+} , MeHg^+ , and PhHg^+ have extremely strong affinities for sulfhydryl-containing ligands. The reactions involved are listed in Eqs. (1)–(3).

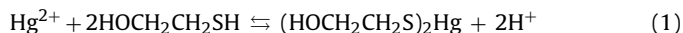

Although these RS–Hg–SR bonds have been demonstrated to be thermodynamically stable, they are kinetically labile [32]. Many studies have demonstrated the need of UV oxidation [28–30] to decompose these organo mercury species. In this work, a singular behavior of Hg^{2+} , MeHg^+ , and PhHg^+ complexes with 2-mercaptoethanol was observed under UV radiation. As it can be seen in Fig. 3, 2-mercaptoethanol prevented MeHg^+ decomposition by UV radiation. However, this behavior changed when 2-mercaptoethanol concentration decreased. On the other hand, Hg^{2+} – and PhHg^+ –2-mercaptoethanol complexes appeared to be more labile, being decomposed by UV radiation and their signal

Table 2
Evaluation of the separation of mercury species.

Mercury species added ($\mu\text{g L}^{-1}$)				Mercury species found under different conditions ($\mu\text{g L}^{-1}$) ^a							
Me ₂ Hg	MeHg ⁺	PhHg ⁺	Hg ²⁺	Condition 1	Relative recovery (%)	Condition 2	Relative recovery (%)	Condition 3	Relative recovery (%)	Condition 4	Relative recovery (%)
0	0	0	100	99.7 ± 9	99.7	99.7 ± 4	99.7	99.7 ± 2	99.7	99.7 ± 9	99.7
0	0	100	0	ND	–	98.9 ± 8	98.9	98.9 ± 4	98.9	98.9 ± 8	98.9
0	100	0	0	ND	–	ND	–	95.9 ± 8	95.9	95.9 ± 8	95.9
100	0	0	0	ND	–	ND	–	ND	–	98.5 ± 9	98.5
50	50	0	0	ND	–	ND	–	47.3 ± 2	47.3	97.5 ± 5	97.5
0	50	50	0	ND	–	49.6 ± 2	49.6	96.2 ± 6	96.2	96.2 ± 8	96.2
0	0	50	50	47.2 ± 3	47.2	99.5 ± 8	99.5	99.5 ± 5	99.5	99.5 ± 7	99.5
50	0	0	50	49.1 ± 4.5	49.1	49.1 ± 4	49.1	49.1 ± 4	49.1	96.9 ± 7	96.9
0	50	0	50	48.4 ± 1	48.4	48.4 ± 4	48.4	95.3 ± 9	95.3	95.3 ± 6	95.3
50	0	50	0	ND	–	49.2 ± 3	49.2	49.2 ± 2	49.2	98.4 ± 7	98.4
25	25	25	25	27.5 ± 1	27.5	48.0 ± 2	48.0	73.9 ± 6	73.9	99.0 ± 8	99.0

Relative recovery = ([mercury found] × 100)/[mercury added].

Condition 1: SnCl₂; Condition 2: SnCl₂ + UV radiation; Condition 3: K₂S₂O₈ + UV radiation; Condition 4: NaBH₄ + UV radiation + K₂S₂O₈.

ND: not detected.

^a The Mercury found corresponds to Hg²⁺ concentration ($\mu\text{g L}^{-1}$) detected by AFS, calculated from the calibration curves of each mercury species.

was not affected by changes in 2-mercaptoethanol concentration. An optimized concentration of 2-mercaptoethanol of 10^{-2} mol L⁻¹ was chosen for both extraction and further determination procedures. This concentration value assured a satisfactory extraction and avoided MeHg⁺ decomposition by UV radiation.

3.2.2. Evaluation of K₂S₂O₈ and NaBH₄ concentrations

The concentration of K₂S₂O₈ was evaluated from 0.1 to 4% (m v⁻¹). MeHg⁺ signal improved with the K₂S₂O₈ concentration. Beyond 1% (m v⁻¹), no significant changes over the mercury signal were observed. A concentration of K₂S₂O₈ of 1% (m v⁻¹) was chosen for further experiments.

On the other hand, the concentration of NaBH₄ is a critical parameter since this reagent allows Me₂Hg determination and the differentiation of Me₂Hg from MeHg⁺ signal during the determination. A dependence of MeHg⁺ and Me₂Hg signals on the presence of different NaBH₄ concentrations can be observed in Fig. 4. Concentrations of NaBH₄ from 0.1 to 4% (m v⁻¹) were evaluated in the presence of a constant K₂S₂O₈ concentration. MeHg signal remained constant versus variations of NaBH₄ concentrations. On the other hand, Me₂Hg was not decomposed by the only presence of K₂S₂O₈ in the system. For Me₂Hg decomposition it was necessary to introduce NaBH₄. Me₂Hg signal increased proportionally with NaBH₄ concentrations. From a concentration of 1% (m v⁻¹) NaBH₄ and on, Me₂Hg was completely decomposed, but beyond this concentration value an increase of the signal noise was observed (Table 2). For this reason, a compro-

mise NaBH₄ concentration of 1% (m v⁻¹) was chosen for further experiments.

3.3. Evaluation of mercury species determination

The recovery of the mercury species under different conditions was evaluated and it can be seen in Table 2. Under the optimized conditions, different concentrations of the evaluated mercury species were combined in order to assess the discrimination capacity of the technique. The employed sequence for the determination of the different mercury species corresponds to:

Condition 1: only SnCl₂ was introduced into the system. As a result, only [Hg²⁺] was determined.

Condition 2: SnCl₂ and UV radiation were introduced to the system achieving PhHg⁺ decomposition. The obtained signal corresponded to [Hg²⁺ + PhHg⁺]. The [MeHg⁺] decomposition was prevented by the addition of 10^{-2} mol L⁻¹ 2-mercaptoethanol.

Condition 3: K₂S₂O₈ was introduced to the system. This reagent achieved MeHg⁺ decomposition and the obtained signal corresponded to [Hg²⁺ + PhHg⁺ + MeHg⁺].

Condition 4: interchanging SnCl₂ by NaBH₄ and introducing it into the system, allowed Me₂Hg determination, corresponding the obtained signal to [Hg²⁺ + PhHg⁺ + MeHg⁺ + Me₂Hg]. As a result, the

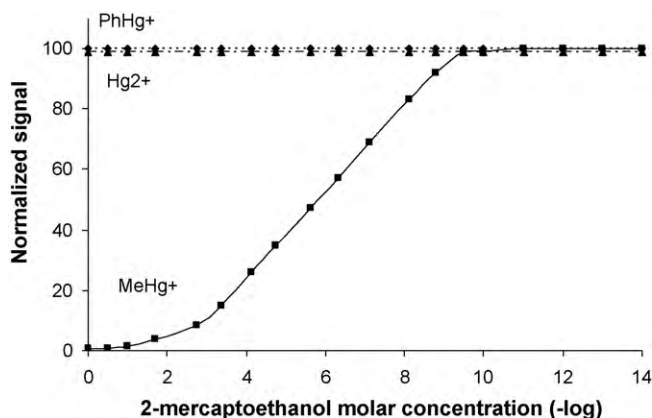

Fig. 3. Dependence of Hg²⁺, MeHg⁺ and PhHg⁺ signals on 2-mercaptoethanol concentration in the presence of UV radiation. Concentration of all Hg species: $1 \mu\text{g L}^{-1}$.

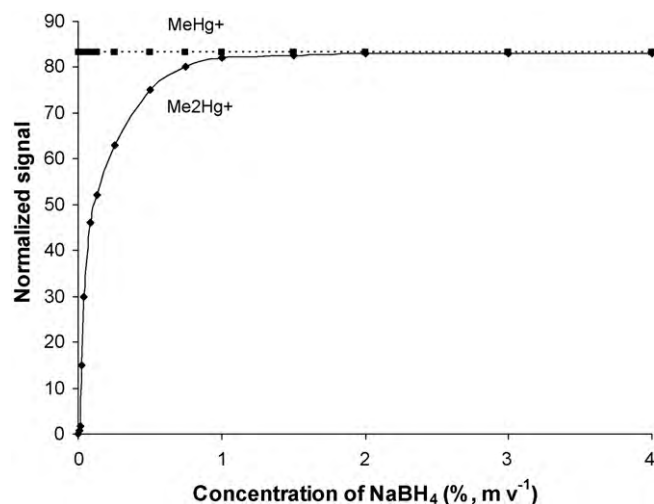

Fig. 4. Dependence of MeHg⁺ and Me₂Hg signals on NaBH₄ concentration in the presence of UV radiation and K₂S₂O₈ 1% (m v⁻¹). Concentration of all Hg species: $1 \mu\text{g L}^{-1}$.

Table 3
Calibration curves under different conditions.

Condition	Linear regression equations
1	$F = 35.40C_{\text{Hg}} + 5.38$ ($R = 0.9947$)
2	$F = 48.08C_{\text{Hg}} + 0.93$ ($R = 0.9988$)
3	$F = 38.61C_{\text{Hg}} + 5.79$ ($R = 0.9984$)
4	$F = 36.92C_{\text{Hg}} + 25.72$ ($R = 0.9995$)

Condition 1: SnCl₂; Condition 2: SnCl₂ + UV radiation; Condition 3: K₂S₂O₈ + UV radiation; Condition 4: NaBH₄ + UV radiation + K₂S₂O₈.

different mercury species (except Hg²⁺, its concentration was evaluated directly) were determined as shown in Eqs. (4)–(6):

$$[\text{PhHg}^+] = [\text{Hg}^{2+} + \text{PhHg}] - [\text{Hg}^{2+}] \quad (4)$$

$$[\text{MeHg}^+] = [\text{Hg}^{2+} + \text{PhHg}^+ + \text{MeHg}^+] - [\text{Hg}^{2+} + \text{PhHg}^+] \quad (5)$$

$$[\text{Me}_2\text{Hg}] = [\text{Hg}^{2+} + \text{PhHg}^+ + \text{MeHg}^+ + \text{Me}_2\text{Hg}] - [\text{Hg}^{2+} + \text{PhHg}^+ + \text{MeHg}^+] \quad (6)$$

Summarizing, following the proposed method the four mercury species were determined. A thorough evaluation of the selectivity of the developed method was performed in order to minimize the risk for misinterpretation of results. The method was applied to various synthetic samples with different concentration relationships between the four species. Complete separation and quantitative recovery can be observed in Table 2. Considering that the four mercury species are quantitatively recovered and determined as Hg²⁺, the calibration procedure was performed against Hg²⁺ standards, avoiding the use organo mercury salts. The calibration procedure was performed under the four mentioned conditions for Hg²⁺ (see above). The corresponding regression equations are detailed in Table 3.

3.4. Stability of mercury species

The manufacturers of the reference materials employed for this work have pointed out the stability of this type of samples [33]. Nevertheless, some recommendations were followed in order to maintain mercury species in its original form in the samples, such as storage at a temperature of –20 °C and, once opened; the entire content of each vial was used avoiding subsampling. Besides, repeated freezing and unfreezing sequences were avoided because methylmercury may decompose specially in some organisms, particularly in bivalves [34].

In addition, the fact that the samples were oven-dried assured an improved stability of mercury samples [35]. It has also been suggested that the analysis of biological tissues is less affected by artifacts and interferences during extraction procedures and quantification [34].

Table 4
Validation of the extraction procedure.

	Hg added (μg L ⁻¹)				Hg found (μg L ⁻¹) ^a				Relative recovery (%)			
	Me ₂ Hg	MeHg ⁺	PhHg ⁺	Hg ²⁺	Me ₂ Hg	MeHg ⁺	PhHg ⁺	Hg ²⁺	Me ₂ Hg	MeHg ⁺	PhHg ⁺	Hg ²⁺
IRMM 813 <i>Adamussium colbecki</i> (candidate CRM)	0.1	0.1	0.1	0.1	0.095 ± 0.002	0.096 ± 0.01	0.098 ± 0.005	0.099 ± 0.003	95	96	98	99
	1	1	1	1	0.926 ± 0.1	0.944 ± 0.04	0.983 ± 0.07	0.979 ± 0.09	92	94	98	97
	10	10	10	10	9.751 ± 0.8	9.871 ± 0.4	9.926 ± 0.7	9.815 ± 0.7	97.5	98.7	99.2	98.1
MURST-ISS-A2 <i>Antarctic Krill</i> (CRM)	0.1	0.1	0.1	0.1	0.097 ± 0.009	0.098 ± 0.002	0.095 ± 0.004	0.096 ± 0.002	97	98	95	96
	1	1	1	1	0.933 ± 0.01	0.932 ± 0.03	0.987 ± 0.05	0.951 ± 0.09	93	93	98	95
	10	10	10	10	9.965 ± 0.5	9.534 ± 0.5	9.872 ± 0.3	9.771 ± 0.4	99.6	95.3	98.7	97.7

Relative recovery = ([mercury found] × 100)/[mercury added].

Condition 1: SnCl₂; Condition 2: SnCl₂ + UV radiation; Condition 3: K₂S₂O₈ + UV radiation; Condition 4: NaBH₄ + UV radiation + K₂S₂O₈.

^a The Mercury found corresponds to Hg²⁺ concentration (μg L⁻¹) detected by AFS, calculated from the calibration curves of each mercury species.

Table 5
Tolerance limits of coexisting ions for determination of Hg.

Foreign ions	Tolerance limit (μg mL ⁻¹)
K ⁺ , Na ⁺	2000
Mg ²⁺	500
Ca ²⁺	2000
Al ³⁺ Zn ²⁺ , Cu ²⁺ , Fe ³⁺	10
NO ₃ ⁻	1000
SO ₄ ²⁻	500
CO ₃ ²⁻	1000
Cl ⁻	5000

3.5. Evaluation of the extraction procedure

There is not a standardized method to assess the extraction efficiency of a particular approach. However, a recent overview has recommended the use of standard additions as the best means to establish the extraction efficiency of a method [4]. Following this premise, the recovery was verified by standard additions at three spiking levels on wet sample after overnight equilibration. As it can be seen from Table 4, the Hg recovery using the proposed extraction procedure was between 92 and 99%.

3.6. Interferences

The effects of possible interfering ions were investigated and results are given in Table 5. The tolerance tests of interfering ions were made at concentration levels at which they may occur in the studied samples and beyond. This test established that the components of Antarctic samples will not interfere in the determination of mercury species.

3.7. Analytical performance

The overall time required for one sample analysis included 1 min per condition (4 conditions) and per mercury species, resulting in a total of 4 min per sample. For washing and conditioning 0.4 min were necessary, thus completing the analysis in 4.4 min and resulting in a sample throughput of 13 samples. This is a very important point, considering the high sample throughput and the future applications of this method for screening and monitoring of mercury species.

The limit of detections (DL), calculated on the basis of the 3σ criterion, and the precisions, calculated as the relative standard deviations (RSD) for five replicate determinations, can be found in Table 6. Linearity was attained from levels close to the detection limit up to at least 100 μg L⁻¹.

3.8. Sample analysis

There is not a standard reference material available with a certified content of the four Hg species determined in this study. In this

Table 6
Limit of detection and relative standard deviation for each mercury species.

Mercury species	Limit of detection (ng L ⁻¹)	Relative standard deviation (RSD, %)
Hg ²⁺	1	1.5
PhHg ⁺	40	3.1
MeHg ⁺	68	4.7
Me ₂ Hg	99	5.8

Table 7
Mercury species concentration in CRM IRMM 813 and CRM MURST-ISS-A2.

Mercury species	CRM	
	IRMM 813 Content (μg g ⁻¹)	MURST-ISS-A2 Content (μg g ⁻¹)
Hg ²⁺	0.1308 ± 0.009	0.0119 ± 0.001
MeHg ⁺	0.0175 ± 0.007	0.0011 ± 0.0001
Me ₂ Hg	ND	ND
PhHg ⁺	ND	ND
Total Hg ^a	0.1474 ± 0.009	0.013 ± 0.001
Total Hg ^b	0.152 ± 0.004	–
Total Hg ^c	–	0.013 ± 0.003

ND: not detected.

^a Extraction procedure (Σ of Hg species).

^b Microwave-assisted digestion.

^c Certified values.

case, a recovery study can be considered as an alternative to estimate accuracy of measurements [36]. The supernatant solutions obtained after the extraction procedure were spiked with different mercury concentrations according to the mercury levels found after the microwave digestion of the candidate CRM IRMM 813 or according to the values informed for the CRM MURST-ISS-A2 material. Three samples of each reference material were analyzed. Mercury concentrations-base values were of 1.2 μg L⁻¹ and 0.104 μg L⁻¹ for CRM IRMM 813 and CRM MURST-ISS-A2, respectively. The materials were spiked with 0.5, 1.0, and 2.0 μg L⁻¹ of Hg²⁺, MeHg⁺, Me₂Hg, and PhHg⁺ for CRM IRMM 813; and with 0.05, 0.10, and 0.20 μg L⁻¹ for CRM MURST-ISS-A2. Mercury species concentrations in each one of the studied samples are listed in Table 7. Mercury levels of each species found in the different samples and materials were in good agreement with total mercury levels. This point was checked by comparing the sum of each mercury species level with the total mercury content obtained by microwave digestion. Furthermore, total mercury levels were correlated with the certified value reported for total Hg in MURST-ISS-A2. Despite the fact that the candidate IRMM 813 *A. colbecki* does not have a certified value for mercury content yet, the obtained results by this extraction method and the microwave digestion approach were in good agreement with those reported by Dalla Riva et al. [14].

This study demonstrated that *A. colbecki* has a higher level of total mercury compared with that certified for the *Antarctic Krill*. *A. colbecki* possesses the higher percentage of organic mercury species. The only mercury species found in *Antarctic Krill* and *A. colbecki* was MeHg⁺. Phenylmercury and dimethylmercury were not detected in any of the studied samples.

4. Conclusions

A novel non-chromatographic methodology for mercury species determination was developed. The proposed method achieved the determination of four mercury species. This procedure is fast and simple becoming adequate for screening procedures and routine analysis. This is the first time that four mercury species are determined via a non-chromatographic method.

The introduced method only required simple and low cost instrumentation, compared with some hyphenated techniques (e.g. HPLC-ICP-MS). AFS demonstrated to be a sensitive technique for the determination of Hg at low concentration levels. The method was successfully applied to the determination of Hg²⁺, PhHg⁺, MeHg⁺, and Me₂Hg in CRM MURST-ISS-A2 *Antarctic Krill* and the candidate reference material IRMM 813 *A. colbecki*. Trace analyses of Antarctic samples become relevant considering that they can be related to global pollution processes.

Acknowledgements

This work was supported by Consejo Nacional de Investigaciones Científicas y Técnicas (CONICET), Agencia Nacional de Promoción Científica y Tecnológica (FONCYT) (PICTBID), Universidad Nacional de San Luis (Argentina), and Comisión Nacional de Energía Atómica (CNEA). The authors would like to thank to Dr. Sergio Caroli for providing the samples.

References

- [1] A. Orkun, E. Nusret, *J. Anal. At. Spectrom.* 24 (2009) 93.
- [2] P.J. Craig, in: P.J. Craig (Ed.), *Organometallic Compounds in the Environment, Principles, and Reactions*, Longman, Leicester, UK, 1986.
- [3] M. Hempel, Y.K. Chau, B.J. Dutka, R. McInnis, K.K. Kwan, D. Liu, *Analyst* 20 (1995) 721.
- [4] M. Leermakers, W. Baeyens, P. Quevauviller, M. Horvat, *Trends Anal. Chem.* 24 (2005) 383.
- [5] J.L. Gomez-Ariza, F. Lorenzo, T. Garcia-Barrera, D. Sanchez-Rodas, *Anal. Chim. Acta* 511 (2004) 165.
- [6] Zsuzsa Jókai, Péter Fodor, *J. Anal. At. Spectrom.* 24 (2009) 1229.
- [7] NRC (National Research Council), *Toxicological Effects of Methylmercury*, National Research Council, Washington, 2000.
- [8] M. Harada, *Crit. Rev. Toxicol.* 25 (1995) 1.
- [9] G.C. Compeau, R. Bartha, *Appl. Environ. Microbiol.* 50 (1985) 498.
- [10] C.J. Watras, R.C. Back, S. Halvorsen, R.J.M. Hudson, K.A. Morrison, S.P. Wente, *Sci. Total Environ.* 219 (1998) 183.
- [11] S. Ciardullo, A. Held, M. D'Amato, H. Emons, S. Caroli, *J. Environ. Monit.* 7 (2005) 1295.
- [12] *Antarctic Environmental Monitoring Handbook*, COMNAPSCAR Publication, Hobart, Australia, 2000.
- [13] ATCM, *Guidelines for Environmental Impact Assessment in Antarctica*, COMNAP, Hobart, Australia, 1999.
- [14] S. Dalla Riva, M.L. Abelloschi, E. Magi, F. Soggia, *Chemosphere* 56 (2004) 59.
- [15] R. Bargagli, F. Monaci, J.C. Sanchez-Hernandez, D. Cateni, *Mar. Ecol. Prog. Ser.* 169 (1998) 65.
- [16] S. Caroli, O. Senofonte, S. Caimi, J. Pauwels, G.N. Kramer, P. Robouch, *J. Anal. At. Spectrom.* 16 (2001) 1142.
- [17] D.R. Turner, in: A. Tessier, D.R. Turner (Eds.), *Metal Speciation and Bioavailability in Aquatic Systems*, John Wiley and Sons, Chichester, 1996.
- [18] J. Zsuzsa, F. Péter, *J. Anal. At. Spectrom.* 24 (2009) 1229.
- [19] X.F. Yin, W. French, E. Hoffmann, C. Lüdke, S. Jochen, *Fresenius J. Anal. Chem.* 361 (1998) 761.
- [20] E. Ramalhosa, S. Rio-Segade, E. Pereira, C. Vale, A. Duarte, *Anal. Chim. Acta* 448 (2001) 135.
- [21] C.C. Wan, C.S. Chen, S.J. Jiang, *J. Anal. At. Spectrom.* 12 (1997) 683.
- [22] I.S. Krull, D.S. Bushee, R.G. Schleicher, S.B. Smith, *Analyst* 111 (1986) 345.
- [23] J. Costa-Fernandez, F. Lunzer, R. Pereiro-Garcia, A. Sanz-Medel, N. Bordel-Garcia, *J. Anal. At. Spectrom.* 10 (1995) 1019.
- [24] L. Magos, *Analyst* 96 (1971) 847.
- [25] F. Ubillús, A. Alegria, R. Barberá, R. Farré, M.J. Lagarda, *Food Chem.* 71 (2000) 529.
- [26] H. Hintelmann, R.D. Wilken, *Appl. Organomet. Chem.* 7 (1993) 173.
- [27] E. Munaf, H. Haraguchi, D. Ishii, *Anal. Chim. Acta* 235 (1990) 399.
- [28] R. Falter, H.F. Schöler, *J. Chromatogr. A* 675 (1994) 253.
- [29] R. Falter, H.F. Schöler, *Fresenius J. Anal. Chem.* 353 (1995) 34.
- [30] R. Falter, G. Ilgen, *Fresenius J. Anal. Chem.* 358 (1997) 401.
- [31] M. Wang, W. Feng, J. Shi, F. Zhang, B. Wang, M. Zhu, B. Li, Y. Zhao, Z. Chai, *Talanta* 71 (2007) 2034.
- [32] A.J. Percy, M. Korbas, G.N. George, J. Gailer, *J. Chromatogr. A* 1156 (2007) 331.
- [33] Programma Nazionale di Ricerche in Antartide (PNRA), Istituto Superiore di Sanità (ISS), MURST-ISS-A2 Antarctic Krill Certified Reference Material for Trace Elements, March 2002.
- [34] T. Stoichev, *Appl. Spectrosc. Rev.* 41 (2006) 591.
- [35] L.P. Yu, X.P. Yan, *Trends Anal. Chem.* 22 (2003) 245.
- [36] E. Prichard, G.M. MacKay, J. Points, *Trace Analysis: A structured Approach to Obtaining Reliable Results*, The Royal Society of Chemistry, United Kingdom, 1996.