

# Inter-comparison of environmental low-cost sensors on Arduino platform

Ariel Fabricio Scagliotti and Guillermo Antonio Jorge

Instituto de Ciencias, Universidad Nacional de General Sarmiento  
CONICET, Buenos Aires, Argentina

## Abstract

*Low-cost sensors for relative humidity, pressure, and ambient temperature have begun to be used regularly for different applications in which the measurement or control of systems or processes is required using an affordable technology. However, in most cases, reliable information about their performance, capabilities, and limitations is not available. In this work, we aim to establish a systematic comparison between different sensors widely used in conjunction with the Arduino platform, such as the DS18B20, DHT11, BMP180, and BME280 sensors. Laboratory and field trials were performed to determine linearity, accuracy, precision, resolution, response times, and response to loss of power. The results indicate that these devices, despite having a very low cost, can provide relatively reliable information, taking into account their manufacturing characteristics and the specific use required. In turn, this work offers useful information to choose the sensor that best suits a particular project.*

## KEYWORDS

Arduino, humidity, performance, pressure, sensors, temperature

## INTRODUCTION

In recent years there has been an increasing interest in the development of autonomous systems for measuring and controlling temperature, atmospheric pressure, and relative humidity in very sensitive areas, such as biomedical<sup>[1]</sup> and biological laboratories,<sup>[2]</sup> storage areas for hazardous substances, and controlled work areas with critical sensitivity.<sup>[3]</sup> These parameters are also of particular importance in environmental monitoring given the tendency to increase both the spatial density of measurement sites and the temporal resolution in each one of them to improve the spatial and temporal precision of predictive models.<sup>[4]</sup> In parallel, there is an emerging technology of low-cost sensors combined with open-source hardware and software, the availability of which has increased exponentially both in device types and quantity.<sup>[5-9]</sup> These devices could enhance measurement capabilities that now rest on more sophisticated and expensive equipment. However, a lack of technical information also makes it difficult to select the sensor that fits better for a specific application. Therefore, there is an urgent need to characterize these kinds of sensors, including their uncertainties and performance, in order to better understand their potentials and limitations.<sup>[6]</sup> In this paper, we summarize the information found in the specific literature about temperature, pressure, and relative humidity low-cost sensors. Then, we propose experimental designs to test and evaluate the sensors under specific criteria. Finally, we report the performance of each sensor complemented with the available information.

## SENSORS SPECIFICATIONS

The sensors that were selected for analysis meet the following conditions:<sup>[6,10]</sup>

- Commercially available worldwide
- Low-cost
- Light and small design
- Require minimum technical expertise to start data collection
- Acquisition rate only limited by micro-processing board

Considering the characteristics described above, the DS18B20 temperature, the DHT11 humidity and temperature, the BMP180 pressure and temperature, and the BME280 humidity, pressure, and temperature sensors, which are commonly used in different open source projects,<sup>[11,13]</sup> were selected.

The DS18B20 (18b20) sensor is a digital thermometer that provides between 9 and 12 bits for temperature measurements. It communicates through a 1-Wire bus that, by definition, requires only one data line (and ground) for communication with a central microprocessor. Additionally, it can derive energy directly from the data line, eliminating the need for an external source.<sup>[14]</sup> It also has a unique 64-bit serial code that allows multiple DS18B20s to work with the same 1-Wire bus.<sup>[15]</sup> This sensor is usually used in thermostatic controls, industrial systems, thermometers, and thermally sensitive systems.<sup>[16]</sup>

The DHT11 (DHT) humidity and temperature sensor have a calibrated digital output signal. It includes a resistive component to measure relative humidity and an NTC semiconductor to measure temperature, both connected to an 8-bit microcontroller. It has a 1-Wire serial communication interface.<sup>[17]</sup>

The BMP180 (BMP) pressure and temperature sensor has an I2C communication interface and is based on piezo-resistive technology.<sup>[18]</sup> This sensor is often used in improvements for GPS navigation, weather forecast, and vertical speed indicator.<sup>[19]</sup>

The BME280 (BME) is a combined humidity, pressure, and temperature digital sensor. This sensor provides both SPI (Serial Peripheral Interface) and I2C communication protocols and can be operated in three modes of consumption: sleep, normal, and forced. It is usually used for health status monitoring, automation, and control, internet of things (IoT), improvements in GPS, weather forecasting, and as a vertical speed indicator.<sup>[20]</sup>

Table 1 shows that all sensors have low power consumption. DHT has the more restricted measurement range. It cannot work with temperatures below 0°C or greater than 50°C (122°F), and it is not able to measure the full possible range of relative humidity. 18b20 has the best accuracy and resolution measuring temperature and BME informs best accuracy and resolution than BMP for measuring pressure.

**Table 1. Sensor's General Characteristics Extracted from the Datasheets**

Parameter/ sensor	18b20	DHT	BMP	BME
<b>Supply voltage</b>	[3;5.5]V	[3;5.5]V	[1.62;3.6]V	[1.71;3.6]V
<b>Current consumption</b>	[1;1.5]ma	[0.5;2.5]mA	[3;32]μA	[1.8;3.6]μA
<b>Measurement range</b>	[-55;125]°C ([-67;257]°F)	[0;50]°C ([32;122]°F); [20;90]%	[-40;85]°C ([-40;185]°F); [300;1100]hPa ([626.6;2297.4]psf)	[-40;85]°C ([-40;185]°F); [0;100]%; [300;1100]hPa ([626.6;2297.4]psf)
<b>Accuracy tolerance</b>	[0.5;2°C]°C ([32.9;35.6]°F)	2°C (35.6°F); 5%	2°C (35.6°F); [2;4.5]hPa ([4.2;9.4]psf)	1°C (33.8°F); 3%; 1hPa (2.1psf)
<b>Resolution</b>	0.0625°C (32.11°F)	1°C (33.8°F); 1hPa (2.1psf)	0.1°C (32.18°F); 0.01hPa (0.02psf)	0.01°C (32.02°F); 0,008%; 0,8hPa (1.7psf)

Different characteristics of the selected sensors were evaluated under known laboratory conditions and contrasted with reference instruments, such as a WT1081 weather station and a PS-2135 rapid response temperature probe connected to a DM3068 digital multimeter. The assessment criteria were based on (i) linearity, (ii) accuracy, (iii) precision, (iv) resolution, (v) response time, and (vi) response to loss of power.

The fast response temperature probe PS-2135 (PS) is a thermistor sensor that measures temperature between  $-10^{\circ}\text{C}$  ( $14^{\circ}\text{F}$ ) and  $+70^{\circ}\text{C}$  ( $158^{\circ}\text{F}$ ) with an accuracy of  $0.5^{\circ}\text{C}$  ( $32.9^{\circ}\text{F}$ ) and resolution of  $0.01^{\circ}\text{C}$  ( $32.02^{\circ}\text{F}$ ).<sup>[21]</sup> These characteristics are limiting for the DM3068 digital multimeter output.<sup>[22]</sup>

The WT1081 weather station (UNGS WS) measures temperature between  $-40^{\circ}\text{C}$  ( $-40^{\circ}\text{F}$ ) and  $+65^{\circ}\text{C}$  ( $149^{\circ}\text{F}$ ) (resolution of  $0.1^{\circ}\text{C}$  ( $32.2^{\circ}\text{F}$ )), relative humidity in a range of 10-99% (resolution of 1%) and pressure between 700hPa (1462psf) to 1100hPa (2297.4psf) (resolution of 0.1hPa (0.2psf)).<sup>[23]</sup> The UNGS WS measures were validated through comparisons with the Argentine National Meteorological Service (SMN) station (CAMPO DE MAYO AERO N°87570).

## METHODOLOGY

### Experimental designs

The data of the sensors was processed with the help of an Arduino UNO board. It has an ATmega 328P microcontroller which represents the basic part of the board and operates with a frequency of 16 MHz. The microcontroller board has 6 analog pins and 14 digital inputs/outputs, of which 6 can be used as PWM (Pulse-Width Modulation) outputs. It also contains +5 V and +3.3 V power pins and 3 GND pins. The board can be powered via USB or a 7-16 V AC to DC adapter.<sup>[24]</sup> An SD card module was used for storing the data during the experiments. Figure 1 shows the basic assembled circuit.

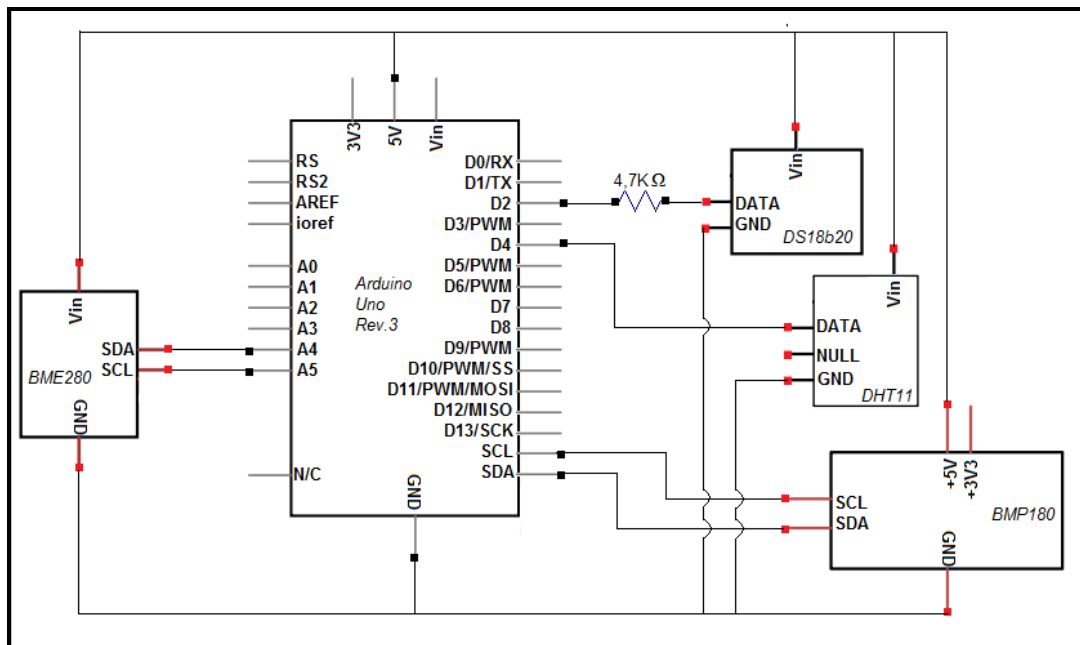

Figure 1. Basic circuit assembled with the Arduino Uno board and sensors BME280, DS18B20, DHT11 and BMP180. The power supply differs according to the type of experiment. The data were stored on an SD card or visualized on a computer or an LCD display.

A sketch of the Arduino IDE 1.8.2 was created for reading the outputs from the sensors and storing the data in an SD card.

As shown in Figure 2(a), we performed trials with different temperatures, relative humidity, and pressure conditions in a chamber designed for this purpose. The temperature was changed with ice packs for temperatures lower than room temperature. The radiation of an infrared lamp was positioned at different distances from the chamber for temperatures higher than room temperature. The relative humidity was controlled by an ultrasonic humidifier, and the pressure was settled through an air pump.



(a)

(b)

Figure 2. a) Experimental design for trials with different values of temperature, relative humidity, and pressure on the chamber. The Arduino board and sensors were powered by a 9V switch power supply for these experiments. b) Compact case with sensors measuring attached to the UNGS WS. The sensors were placed in a plastic outer shield.

To compare the low-cost sensors data with the UNGS weather station, a compact case was designed containing the sensors, a DS3231 real-time clock, and an SD card module controlled by an Arduino Uno board. All were powered by a 7.4 V/1300 mAh LiPo battery. This case was placed beside the UNGS weather station in different planned stages, as can be seen in Figure 2(b).

## Evaluation parameters

### (i) Linearity

The linearity was evaluated by plotting the outputs of the sensors against the reference instruments using the least-squares regression. The linear correlation coefficients of Spearman ( $R^2$ ) were calculated, which expresses the strength of the linear relationship between the average sensor measurements and the values of the reference instrument. The mean square error (MSE) was calculated as a measure of variance and bias in the behavior of the sensors.

For comparing the output of the sensors with the PS-2135, the temperature in the laboratory chamber was changed and the data points were collected when every output of the sensors reached a stationary state. The data collection of the sensors for comparing with the temperature, humidity, and pressure UNGS weather station data was taken in different campaigns with duration of 40 hours each. The sampling rate in all the experiments was settled in 100 milliseconds, and hour averages were calculated for analysis.

### (ii) Accuracy

Accuracy refers to the closeness between the measured and the actual values. In the absence of universal calibration curves for the analyzed sensors and the reference sensors or standard instruments, the linear correlations described above were used to assess the accuracy of the sensors and standard deviations relative to the reference instruments (RED) were calculated.<sup>[25]</sup>

### (iii) Precision

Precision represents the variation around an average value in repeated measurements of the same variable under identical or similar experimental conditions.<sup>[6]</sup> We determined the precision with (1):

$$P(\%) = 100 - \frac{\bar{E}_s}{\bar{x}} \quad (1)$$

where  $\bar{x}$  is the average value and  $\bar{E}_s$  is the standard error of the average value of the sensors during the periods considered as steady state. The standard error is calculated according to (2):

$$\bar{E}_s = \frac{\sqrt{\sum(x-\bar{x})}}{n} \quad (2)$$

where  $n$  is the number of measurements and  $x$  represents every data measured.

The precision was calculated when the stationary states were reached in the laboratory chamber experiments. For temperature, 11 samples were used with a mean value of 28°C (82.4°F) on the PS sensor. For relative humidity, 10 samples were used with a mean value of 46% on the UNGS WS. For the pressure, 23 samples were used with a mean value of 1015hPa (2119.9psf) on the UNGS WS.

#### **(iv) Resolution**

Resolution is defined as the smallest change in the output signal of a sensor that can be reliably detected. This term is determined by the noise of the instrument, understood as spontaneous deviations of short duration in measurements or output signals of measurements on the average output that are not caused by changes in the levels of the variable being measured.<sup>[10]</sup> In this work, the resolution is informed as the standard deviations of the output signals of the sensors calculated during the different stationary states achieved in the laboratory chamber tests. In this case too, the temperature, relative humidity, and pressure data were used. The standard deviations of datasets measured during 1 minute of steady-state for each variable (600 samples on each dataset) were calculated.

#### **(v) Response time**

To evaluate the response time of the sensors, two parameters were tested:<sup>[10]</sup>

- Lag time: defined as the time interval between a change in the variable and the first observable change in the measurement response. That observable change is considered as the accuracy tolerance informed on the datasheets.
- Rise time: time interval between the initial response time and 95% of the final response after an increase in the variable

The sensors were put through instant changes of temperature (22°C (71.6°F) to 28°C (82.4°F)), relative humidity (45% to 58%) and pressure (1013hPa (2115.7psf) to 1015hPa (2119.9psf)) in the laboratory chamber and the lag and rise times were measured. The sampling frequency was set to 1ms for these experiments, except for the rise time measures with temperature changes which was settled on 100ms.

#### **(vi) Response to loss of power**

The response to loss of power is the amount of time a sensor takes to enter in regime and become operational after a loss of energy.<sup>[6]</sup> The energy to the sensors was cut off and reestablished several times, and the data sets registered were plotted and analyzed. Every data set has 147 samples with a sampling frequency of 100ms and an energy interruption every 20 samples.

## **RESULTS AND DISCUSSION**

As is shown in Table 2, all coefficients of Spearman ( $R^2$ ) results were  $\geq 0.94$ , which means a good linear adjustment on the comparisons of all sensors with the references. Figure 3 shows this for the temperature outputs of sensors against PS with all slopes close to 1. Figure 4 shows the same feature for temperature outputs of sensors against UNGS WS, where DHT and BMP have slopes close to 1, but BME and 18b20 show higher slopes. The mean squared errors (MSE) are significantly big for the relative humidity trials, which is seen as high dispersion on the plots of relative humidity outputs of BME and DHT against UNGS WS in Figure 5. This figure also shows a slope closer to 1 for DHT, but with nonlinear behavior on extremes values. The temperature comparisons against PS results in higher MSE and lower  $R^2$  than against UNGS WS, which can be explained with the higher temperatures used in the first case. Figure 6 shows the linearity of pressure outputs from BMP and BME against UNGS WS.

Accuracy results can be seen also in Table 2 with the RED values. With PS as a reference, the 18b20 sensor shows higher temperature accuracy. However, with UNGS WS as a reference, there were no significant differences between sensors.

**Table 2. MSE, R<sup>2</sup>, and RED from Comparisons of Sensors with PS and UNGS WS**

Sensor	MSE/R <sup>2</sup> (UNGS WS)	MSE/R <sup>2</sup> (PS)	RED (UNGS WS)	RED (PS)
BME (T)	2.1/0.99	4.0/0.95	0.02°C (32.04°F)	0.06°C (32.11°F)
18b20 (T)	1.3/0.99	4.1/0.95	0.02°C (32.04°F)	0.04°C (32.07°F)
BMP (T)	0.1/0.99	5.0/0.94	0.02°C (32.04°F)	0.07°C (32.13°F)
DHT (T)	2.2/0.99	3.7/0.94	0.03°C (32.05°F)	0.06°C (32.11°F)
BME (RH)	45.7/0.99		0.02%	
DHT (RH)	80.5/0.95		0.03%	
BME (P)	0.1/0.99		0.03hPa (0.06psf)	
BMP (P)	0.1/0.99		0.01hPa (0.02psf)	

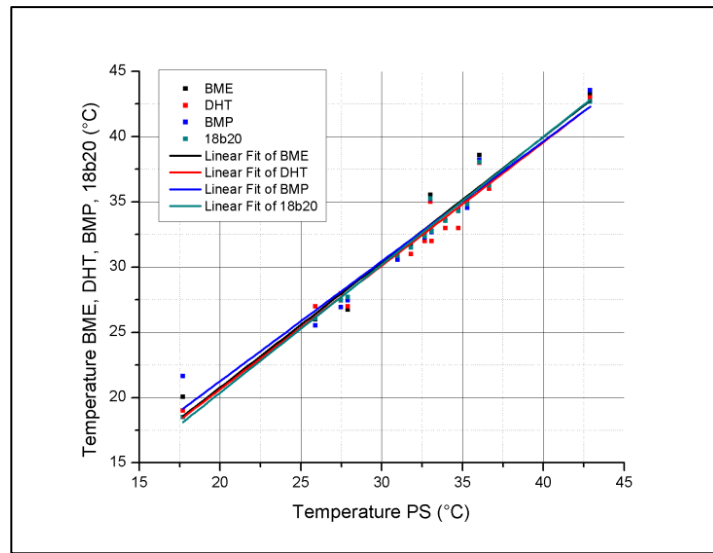

*Figure 3. Temperature outputs of sensors against PS with linear adjustment. The slopes are very similar in all cases and close to 1.*

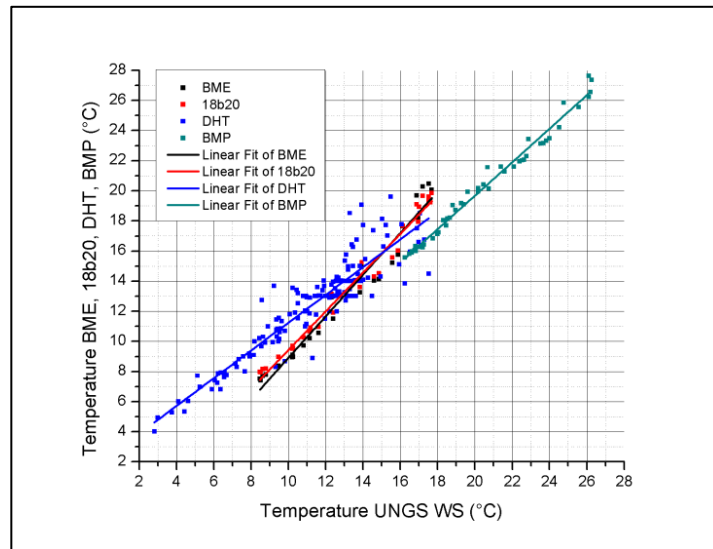

*Figure 4. Sensors temperature output against UNGS WS with linear adjustment. A higher dispersion is seen for the DHT measurements.*

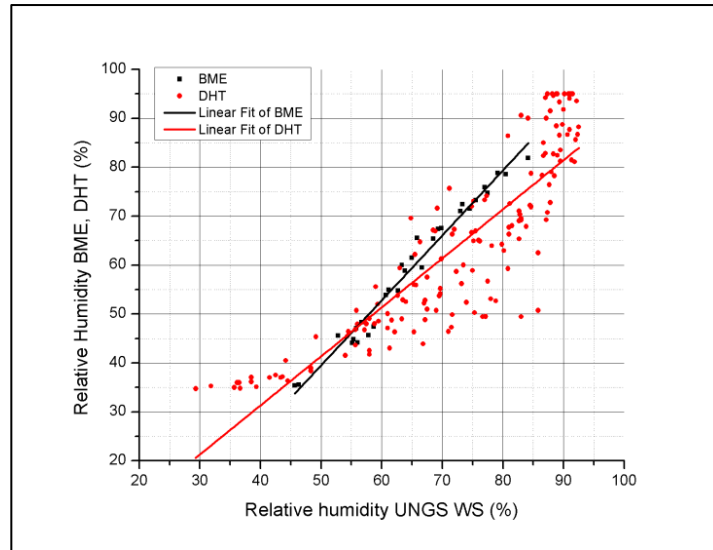

Figure 5. Relative humidity outputs of BME and DHT against UNGS WS with linear adjustment. DHT presents a higher dispersion and different slope than BME.

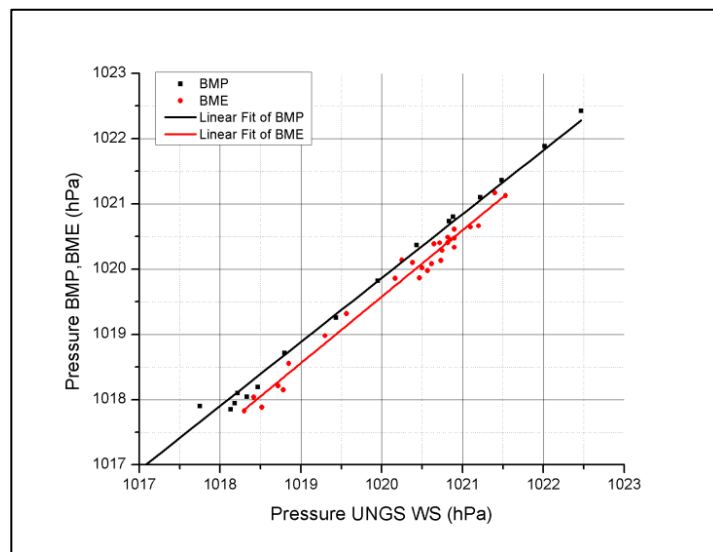

Figure 6. Pressure outputs of BMP and BME against UNGS WS with linear adjustments.

As can be seen in Table 3, precision results are very high in all sensors measurements. Table 3 also shows that the BME sensor has the best resolution for temperature, and the BMP sensor has the best resolution for pressure. The poor resolution of DHT limited the calculations for this sensor; thus, its precision is not a reliable result, and its resolution is informed as in the datasheet.

Regarding the response time, there were remarkable differences between the sensors. The lag time results were very high for DHT, again because of its poor resolution. The lag time of 1500s for the BMP temperature sensor compared with the 1 s lag for 18b20 or 5s for BME on the same parameter is striking, but it can be explained with its high accuracy tolerance value. The pressure sensors show a low lag time also, as the relative humidity for BME. The lag times equal to 1ms are not reliable results because that is the sampling frequency; however, it can be said that those lag times are lower than 1ms. The rise time results in 1s for the pressure sensors (again, this must be interpreted as  $\leq 1$ ms), 23s for relative humidity

with DHT, and 30s for relative humidity with BME. In the case of temperature measurements, the shorter rise time was for DHT and the higher rise time was for BME, as can also be seen in Figure 7.

**Table 3. Precision, Resolution Lag Time, and Rise Time Calculated for All Sensors**  
[The data output of DHT is limited by a resolution equal to the unity.]

Sensor	Precision (%)	Resolution	Lag time (s)	Rise time (s)
BME (T)	98.7	0.01°C (32.02°F)	5	665.0
18b20 (T)	98.8	0.05°C (32.09°F)	1	253.5
BMP (T)	98.8	0.04°C (32.07°F)	1,500	350.0
DHT (T)	98.8	1.00°C (33.8°F)	5,000	96.5
BME (RH)	98.7	0.09%	4	30.0
DHT (RH)	98.4	1.00%	58,000	23.0
BME (P)	99.9	0.86hPa (1.8psf)	1	1.0
BMP (P)	99.9	0.05hPa (0.1psf)	1	1.0

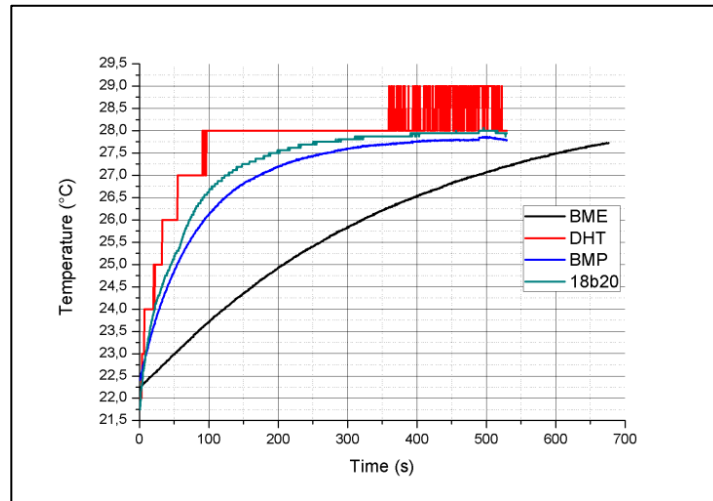

*Figure 7. Rise time measures with temperature outputs.*

Regarding the response to loss of power, it was not possible to measure a recovery time because the variation of the data for every sensor after energy cut off was not significant compared with the corresponding accuracy tolerance informed on Table 1.

## CONCLUSIONS

Although the performance characteristics and ease of use of the sensors evaluated here vary widely, there is strong evidence that they have immediate use in a wide range of applications. These devices can provide useful information about environmental characteristics at a scientific level with an appropriate framework that evaluates their performances.

The trials carried out in laboratory and outdoors enabled the measurement of results under different experimental conditions, which contributes to a better understanding of the behavior of the sensors. The results of this work are not intended to replace the information of the datasheets, but they do reflect comparatively the operation of the different sensors submitted to the same conditions.

From the information in the datasheets, two limitations in the DHT could be determined, one regarding its inability to measure negative temperatures as well as its inability to measure the full possible range of relative humidity, and another regarding the fact of having only integer values as output. This reduced the possibilities of statistical treatment of its data.



Linearity results show that relative humidity sensors present some difficulties in terms of the dispersion of their data reflected in high MSE values, especially with DHT that have non-linear regions close to its detection limits. The temperature measurement results were satisfactory for all the sensors, and the best linear adjustments were given in the comparisons of the pressure values. The differences in the slopes indicate that a previous calibration is necessary to use the data of these sensors in different projects.

Accuracy proved to be satisfactory in all cases, with a small advantage of the 18b20 in laboratory experiments. The precision was also good for all the sensors. The resolution results were similar to those reported by the datasheets with the BME as the finest, although the differences between 18b20 and BMP were much smaller in this work. Regarding the pressure, the BMP had a better resolution than the BME.

The lag time was high in the case of DHT due to its poor resolution and for BMP temperature measurements due to its high accuracy tolerance value. The results of the rise time were interesting since there were notable differences between the temperature sensors. The DHT had the shortest rise time followed by 18b20, while the BME took the longest time to reach the expected value.

The loss of energy does not seem to affect the measurements of any of the sensors, so it can be considered that they have a rapid warm-up response.

Depending on the type of project to implement, these results can help in some sensor choices. It can be said that the DHT sensor measurements in relative humidity are not reliable. On the other hand, if precision and good resolution are sought in temperature measurements, both BME and 18b20 are good options, especially if there is the possibility of practicing a previous calibration. However, if a rapid response temperature sensor is desired as is the case of control systems, then 18b20 is more convenient. Regarding projects of environmental measurements with natural variations, the BME is the best option because it had good results in the three parameters it measures. Regarding pressure measurements, both BME and BMP had favorable results, with a small advantage on the part of BMP.

The information provided by this work represents a contribution in the way of improving the performance and adaptability of the next generation of sensors. It also provides useful information and criteria that users need to understand to successfully execute a collection of data based on their specific monitoring needs. A greater number of studies are necessary to expand the results presented here, especially using standard devices for comparisons and greater control of laboratory parameters that allow simulating extreme and more precise values.

## **SUMMARY**

- Low cost sensors for relative humidity, pressure and ambient temperature are gaining popularity.
- Reliable information about their performance, capabilities, and limitations is not easily available.
- We aim to establish a systematic comparison between different sensors widely used (DS18B20, DHT11, BMP180, and BME280) for linearity, accuracy, precision, resolution, response times, and response to loss of power.
- These devices, despite having a very low cost, can provide relatively reliable information.
- This paper contains useful information for choosing the sensor that best suits a particular project, and criteria needed to successfully execute a collection of data based on specific monitoring needs.

## **ACKNOWLEDGEMENT**

We would like to acknowledge the National Meteorological Service (SMN) to provide us the necessary data for validating the UNGS WS sensors, and the Arduino community for providing very important tools for open source projects development. Also, we want to thank Carlos Jech and Alejandro Parodi for their assistance with the instruments and materials. ICI-UNGS provided the financial support for this work.

## REFERENCES

1. McNeill, J., D. Sen, Y. Mendelson, M. Crivello, S. Mazumder, A. Agdeppa, ... and K. Hickie. 2017. Wearable wireless sensor patch for continuous monitoring of skin temperature, pressure, and relative humidity. *IEEE Int. Symp. Circuits and Systems (ISCAS)*: 1–4.
2. Aitken-Christie, J., T. Kozai, and M. A. L. Smith (eds.). 2013. *Automation and environmental control in plant tissue culture*. Springer Science & Business Media.
3. Bartholmai, M., E. Köppe, and P. P. Neumann. 2013. Monitoring of hazardous scenarios using multi-sensor devices. *4th Int. Conf. Sensor Device Technologies Applications*: 9–13.
4. López, F. R. J. and A. J. López. 2012. Field variables monitoring in real time (GPS, soil moisture, temperature) with precision farming applications. *Proc. 6th Euro American Conf. Telematics Info. Systems*.
5. Lin, C., J. Gillespie, M. D. Schuder, W. Duberstein, I. J. Beverland, and M. R. Heal. 2015. Evaluation and calibration of Aeroqual series 500 portable gas sensors for accurate measurement of ambient ozone and nitrogen dioxide. *Atmospheric Environment* 100:111–116.
6. Polidori, A., V. Papapostolou, and H. Zhang. 2016. Laboratory Evaluation of Low-Cost Air Quality Sensors. *South Coast Air Quality Management District: Diamondbar, CA, USA*.
7. Correa, N. M., M. Santamaria, S. Guerra, J. E. Moreno, and Y. E. Moreno. 2017. Selección de sensores para la adquisición de datos atmosféricos utilizando la plataforma de hardware libre arduino. *Tecnociencia* 19 (2): 103–120.
8. Papapostolou, V., H. Zhang, B. J. Feenstra, and A. Polidori. 2017. Development of an environmental chamber for evaluating the performance of low-cost air quality sensors under controlled conditions. *Atmospheric Environment* 171:82–90.
9. Škultéty, E., E. Pivarčiová, and L. Karrach. 2018. The comparing of the selected temperature sensors compatible with the Arduino platform. *Management Systems in Production Engineering*.
10. Williams, R., R. Long, M. Beaver, A. Kaufman, F. Zeiger, M. Heimbinder, ... and K. Kupcho. 2014. Sensor evaluation report. *US Environmental Protection Agency*: 21–28.
11. Aneja, B., S. Singh, U. Chandna, and V. Maheshwari. 2011. Review of Temperature Measurement and Control. *Int. Journal Electrical Electronics Engineers* 3 (2): 29–37.
12. Sose, D. V. and A. D. Sayyad. 2016. Weather monitoring station: a review. *Int. Journal Engineering Research Application* 6 (6): 55–60.
13. Hapsari, A. A., A. I. Hajamydeen, and M. I. Abdullah. 2018. A review on indoor air quality monitoring using IoT at campus environment. *Int. Journal Engineering Technology* 7 (4.22): 55–60.
14. DS18B20 Datasheet. (<https://cdn-shop.adafruit.com/datasheets/BST-BMP180-DS000-09.pdf>)
15. Gricius, G., D. Drungilas, A. Andziulis, D. Dzemydiene, M. Voznak, M. Kurmis, and S. Jakovlev. 2015. Advanced approach of multiagent based buoy communication. *The Scientific World Journal*.
16. Jing, H. 2015. Design and Development of the Temperature Detection System. *Int. Journal Control Automation* 8 (2): 409–416.
17. DHT11 Datasheet. (<https://image.dfrobot.com/image/data/KIT0003/DHT11%20datasheet.pdf>)
18. BMP180 Datasheet. (<https://cdn-shop.adafruit.com/datasheets/BST-BMP180-DS000-09.pdf>)
19. Kim, Y. K., S. H. Choi, H. W. Kim, and J. M. Lee. 2012. Performance improvement and height estimation of pedestrian dead-reckoning system using a low cost MEMS sensor. *12th Int. Conf. Control, Automation, Systems*: 1655–1660.
20. BME280 Datasheet. (<https://image.dfrobot.com/image/data/KIT0003/DHT11%20datasheet.pdf>)
21. PS-2135 fast response temperature probe Instruction Sheet. ([https://www.pasco.com/file\\_downloads/Downloads\\_Manuals/PASPORT-Fast-Response-Temperature-Probe-Manual-PS-2135.pdf](https://www.pasco.com/file_downloads/Downloads_Manuals/PASPORT-Fast-Response-Temperature-Probe-Manual-PS-2135.pdf))
22. DM3068 datasheet. (<http://beyondmeasure.rigoltech.com/acton/attachment/1579/f-0052/0/-/-/-/-/file.pdf>)

23. WT1081 User's Manual. (<http://www.meteostar.com.ar/descargas/estaci%C3%B3n-meteorol%C3%B3gica-wt1081-meteostar.pdf>)
24. Arduino Uno R3 Datasheet. (<http://static6.arrow.com/aropdfconversion/97b354c3cd11851042ebd1fd252fbd6b6def5a73/adafruit2877arduinouno.pdf>)
25. Wang, Y., J. Li, H. Jing, Q. Zhang, J. Jiang, and P. Biswas. 2015. Laboratory evaluation and calibration of three low-cost particle sensors for particulate matter measurement. *Aerosol Science and Technology* 49 (11): 1063–1077.

## ABOUT THE AUTHORS

**Ariel Scagliotti.** Professor in physics from the University of General Sarmiento (Buenos Aires, Argentina), Ph.D. fellow of the National Research Council of Argentina (CONICET) and assistant professor in University of General Sarmiento. Has experience in low-cost technology development applied to environmental sciences and with educational purposes. Also has research experience on air pollution modeling and meteorological analysis.

**Guillermo Jorge.** PhD in physics from the University of Buenos Aires, independent researcher of the National Research Council of Argentina (CONICET) and the National University of General Sarmiento (Buenos Aires, Argentina). He has research experience in experimental materials physics, sensor design, low temperature physics, physics in high magnetic fields, thermodynamic properties and electrical transport, among others. Also focused on technical-social issues, environmental impact and renewable energy.

*Contact Author: Ariel Scagliotti, [afscaglio@gmail.com](mailto:afscaglio@gmail.com), Instituto de Ciencias, Universidad Nacional de General Sarmiento, CONICET, Buenos Aires, Argentina*

---

The Institute of Environmental Sciences and Technology (IEST), founded in 1953, is a multidisciplinary, international technical society whose members are internationally recognized for their contributions to the environmental sciences in the areas of contamination control in electronics manufacturing and pharmaceutical processes; design, test, and evaluation of commercial and military equipment; and product reliability issues associated with commercial and military systems. IEST is an ANSI-accredited, standards-developing organization. For more information about the many benefits of IEST membership, visit [www.iest.org](http://www.iest.org).