

## A Morphology-based Cladistic Analysis of *Paspalum* sect. *Pectinata* (Poaceae)

GABRIEL H. RUA<sup>1,3</sup> and SANDRA S. ALISCIONI<sup>2</sup>

<sup>1</sup>Cátedra de Botánica Agrícola, Facultad de Agronomía, Universidad de Buenos Aires, Avenida San Martín 4453, 1417 Buenos Aires, Argentina (ruagabri@mail.agro.uba.ar);

<sup>2</sup>Instituto de Botánica Darwinion, Labardén 200, casilla de correo 22, 1642 San Isidro, Argentina (saliscioni@darwin.edu.ar)

<sup>3</sup>Author for correspondence

Communicating Editor: Kathleen Kron

**ABSTRACT.** A cladistic analysis using parsimony was carried out, including all six species of *Paspalum* sect. *Pectinata* plus an outgroup composed of six species of *Paspalum* subg. *Ceresia*, six additional *Paspalum* species belonging to different taxonomic groups, and two extrageneric taxa. The analysis was based on 65 morphological characters and was performed using both equal weights and implied weights. In all resulting cladograms, a well supported clade corresponding to *Paspalum* sect. *Pectinata* appears, with either *P. ceresia* or a clade comprising *P. ceresia*, *P. stellatum*, and *P. eucomum* as sister group. Within the *Pectinata*-clade *P. lanciflorum* emerges consistently as sister taxon to the remainder of the section, whereas the phylogenetic relationship among them is poorly resolved. The inclusion of *Paspalum* sect. *Pectinata* within a weakly supported subgenus *Ceresia* is confirmed. Incidentally, some doubt is thrown about the validity of the currently accepted circumscription of *Paspalum* subg. *Ceresia*, since the inclusion of *P. humboldtianum* and *P. polyphyllum* within it is not supported by our data.

The genus *Paspalum* L. comprises about 400 species of grasses mostly distributed in tropical and warm-temperate areas of South and North America (Chase 1929; Clayton and Renvoize 1986), with their main center of diversity in the American tropics (Judziewicz 1990). They can be recognized by unilateral raceme-like partial inflorescences and plano-convex spikelets lacking the lower glume, although none of these characters are exclusive to the genus. Within the subfamily Panicoideae, *Paspalum* belongs to the clade characterized by a chromosome base number  $x=10$  and is related to other genera having a NADP-ME photosynthetic pathway (Giussani et al. in press; see also Gómez-Martínez and Culham 2000). Although a comprehensive hypothesis about phylogeny of *Paspalum* is not yet available, the lack of a unique character throws doubts on the monophyly of the genus.

Following Chase (1929), the species of *Paspalum* are usually classified in two subgenera—*Ceresia* and *Paspalum*—and about thirty informal groups are recognized on the basis of morphological similarity. Within the subgenus *Ceresia*, characterized by a membranous rachis and the spikelets “clothed with long silky hairs or conspicuously fringed with long hairs” (Chase 1929), a distinct group of species was later recognized by Chase as the *Pectinata* group (Chase 1939). The species belonging to the *Pectinata* group are distributed from southern Mexico to Bolivia and central Brazil, and show a unique set of characters that suggest the group to be monophyletic. The *Pectinata* group was formally proposed as a section by Rodríguez (1992), but was provided an ambiguous diagnosis based on the spikelet shape and the geographical distribution. Later, Renvoize (1995) redefined the section *Pectinata* as pos-

sessing spikelets that are “strongly dorsiventrally flattened, imbricate, and lanceolate in shape”, and the upper glume “usually winged and cordate”, and recognized seven species as belonging to this section. Because *P. setiglume* Chase must be synonymized with *P. aspidiotes* Trin. (F. Zuloaga and O. Morrone, pers. comm.), six species remain in the section.

The aim of the present paper is to test the hypothesis of monophyly of *Paspalum* sect. *Pectinata*, to assess the phylogeny within this section, and to explore the phylogenetic relationships with other species of the genus *Paspalum*.

### MATERIALS AND METHODS

**Ingroup Taxa.** All currently accepted species of *Paspalum* sect. *Pectinata* (Renvoize 1995; Zuloaga and Morrone, pers. comm.) were included in our analysis: *P. aspidiotes* Trin., *P. cordatum* Hack., *P. imbricatum* Filg., *P. lanciflorum* Trin., *P. pectinatum* Nees ex Trin., and *P. reticulinerve* Renvoize. Presumed autapomorphies of each species are listed in Table 1.

With the exception of *P. lanciflorum*, the remaining *Pectinata* species share a cordate upper glume, a character that does not occur in any other *Paspalum* species. *Paspalum lanciflorum* was included in the section *Pectinata* because of their large imbricate spikelets with a winged upper glume (cf. Rodríguez 1992; Renvoize 1995), but this species also shares some features—a tuft of hairs at the base of the spikelet, a caducous upper floret—with other species of the subgenus *Ceresia*. Hence, their inclusion in the section *Pectinata* is somewhat dubious and needed to be tested through a cladistic analysis.

In spite of the copious literature on cytogenetics of *Paspalum* species, there is almost no information about the species belonging to sect. *Pectinata*. The only references we found are a chromosome count of  $n = 10$  for *P. pectinatum* (Pohl 1980) and a mention of a base number  $x = 9$  for *P. lanciflorum* (sub nom. *P. contractum*, Davids and Pohl 1974), the latter being an unusual case among *Paspalum* species. No data are available about polyploidy and hybridization within section *Pectinata*, both of which have been repeatedly reported among *Paspalum* species. Thus, there is no evidence

TABLE 1. Suggested autapomorphies of the species of *Paspalum* sect. *Pectinata*.

<i>P. aspidiotes</i>	Upper glume ciliate at apex
<i>P. cordatum</i>	No clear autoapomorphies
<i>P. imbricatum</i>	Upper glume and lower lemma glabrous
<i>P. lanciflorum</i>	Upper floret stipitate, chromosome base number $x = 9$
<i>P. pectinatum</i>	No clear autapomorphies
<i>P. reticulinerve</i>	Glume and lemma lateral "wings" reticulately nerved, lower lemma "responssé"

supporting a hybrid origin that justifies the removal of any species from the analysis.

**Outgroup Taxa.** Several other *Paspalum* species were included as potential outgroups. The presumptive most closely related species are those of the subgenus *Ceresia* not included in the section *Pectinata* (about 24 species, hereafter called 'the *Ceresia* group'). They share several potential synapomorphies with members of section *Pectinata*, the most striking being the membranous winged rachis. Six species belonging to the *Ceresia* group were included in our analyses: *P. carinatum* Humb. et Bonpl. ex Flügge, *P. stellatum* Humb. et Bonpl. ex Flügge, *P. ceresia* (Kuntze) Chase, *P. eucomum* Nees ex Trin., *P. humboldtianum* Flügge, and *P. polyphyllum* Nees ex Trin. They were chosen either because they share characters with species of the sect. *Pectinata*, or because they mostly represent the variation occurring within the group.

Although *P. humboldtianum* and *P. polyphyllum* lack the distinctive membranous rachis, most authors agree on the inclusion of them in subgenus *Ceresia* because of their hairy spikelets (cf. Chase 1929, 1939; Pilger 1940; Rodríguez 1998). Nevertheless, Parodi and Nicora (1966) placed both species in a different group—the series *Humboldtiana* Parodi—together with *P. paucifolium* Swallen (sub nom. *P. mesopotamicum* Parodi). This species was otherwise considered a member of the *Eriantha* group (cf. Swallen 1967; Barreto 1974)—one of the informal groups usually recognized within the subgenus *Paspalum* (cf. Chase 1939)—on the basis of rhizome morphology, racemes with a narrow rachis, and hairy spikelets. For the purpose of improving the outgroup resolution, *P. paucifolium* and *P. ammodes* Trin.—another species that was alternatively placed either in the *Ceresia* group (Chase 1939) or in the *Eriantha* group (Judziewicz 1990)—were also included in our analyses. Furthermore, four additional *Paspalum* species were included. These were selected either because some characters are shared with the sect. *Pectinata* (*P. cromyorrhizon* Trin. ex Döll, *P. lineare* Trin.) or because a comprehensive herbarium sample was available (*P. notatum* Flügge, *P. paniculatum* L.). *Panicum obtusum* Kunth and a species of the genus *Anthaenantiopsis* Pilg. were also included because both have been shown to be related to *Paspalum* in recent DNA analyses (Gómez-Martínez and Culham 2000; Giussani et al. in press). For the purpose of rooting *Anthaenantiopsis fiebrigii* Parodi was chosen.

Because "the resolution among multiple outgroup terminals [...] may affect both the position of the ingroup relative to outgroups and the topology of relationships within the ingroup" (Nixon and Carpenter 1993: 422), several characters were included in our analyses in order to resolve outgroup relationships.

**Material.** Morphological characters were scored from herbarium material. Specimens belonging to the following herbaria were examined (acronyms after Holmgren et al. 1990): B, BAA, CTES, LPB, MO, SI, US, and USZ. For a complete list of specimens studied see Appendix 1. All authorities are cited in agreement with Brummitt and Powell (1992). Whenever possible, morphological data were corroborated on living material, through field observations as well as examination of plants cultivated in the "Lucien Hauman" Botanical Garden, Facultad de Agronomía, Universidad de Buenos Aires, Argentina (*P. reticulinerve*, *P. lanciflorum*, *P. stellatum*, *P. ceresia*, *P. humboldtianum*, *P. polyphyllum*, *P. paucifolium*, *P. notatum*, *P. cromyorrhizon*, *P. lineare*, and *P. paniculatum*). Morphological characters related to inflorescence structure (40–49) and growth habit (50–52) were scored according to Rua and Gróttola (1997) and Rua and Weberling (1998).

Leaf sheaths and leaf blades of all studied species were taken

from herbarium material, soaked in a non-ionic detergent solution at 70°C for 1 hr, hand sectioned, stained with Alcian Blue and Safranin, mounted in glycerine jelly, and studied using a Wild M20 light microscope.

Observations of epidermal features of the upper floret were made with a JEOL JSM-T100 scanning electron microscope (SEM) at the Museo de Ciencias Naturales de La Plata (La Plata, Argentina) and with a Zeiss DSM 940 SEM at the Instituto de Botánica "Darwinion" (San Isidro, Argentina).

**Characters.** Sixty-five morphological characters (state assignments for taxa in Appendix 2) were defined for use in the analyses, 36 of which showed variation at the ingroup level. The remaining characters were included either as possible synapomorphies joining the section *Pectinata* with species from the outgroup, or as informative characters for the outgroup only. Characters that provide information to resolve outgroup relationships reduce the number of most parsimonious trees found due to multiple equal parsimonious resolutions of the outgroup. Autapomorphies (Table 1) were not included in our analyses. Polymorphic characters were scored as such, as recommended when the polarity of the characters are unknown from previous analyses (Kornet and Turner 1999). Missing data (including unavailable as well as inapplicable data) represent 2% of the entries in the data matrix.

#### Lower glume.

1. Lower glume development: fully developed (0), obsolete (1), absent (2).

#### Upper glume.

2. Length: less than 2 mm (0), 2–4 mm (1), more than 4 mm (2). The studied species are roughly arranged into three groups according to the length of the upper glume. In *P. carinatum* the glume length ranges between 3.5 and 4.2, so it was coded as polymorphic (Fig. 1 A).

3. Shape of the basal portion: not auriculate (0), auriculate (1).

4. A tuft of long hairs at the base of the glume: absent (0), present (1).

5. A marginal fringe of tuberculate hairs: absent (0), present (1). Tuberculate hairs are surrounded by "cushions" made up of large protruding epidermal cells (cf. Metcalfe 1960: xxii). In several *Paspalum* species tuberculate hairs are arranged into two rows along each margin of the upper glume, which appear fringed.

6. Indumentum of the abaxial epidermis: glabrous (0), pubescence made of hairs not conspicuously tuberculate at the base (1), pubescence of tuberculate hairs (2). Beyond the basal tuft (character 4) and the fringe of tuberculate hairs (character 5), pubescence can cover to some extent the abaxial surface of the glume. This indumentum may or may not be composed of hairs with a conspicuous "cushion" at the base.

7. Number of lateral veins on each half of the glume: one (1), two (2), three (3), four or more (4).

8. Abaxial vein protrusion: veins not prominent (0), prominent (1).

9. Distal convergence of midvein and (inner) lateral veins: not convergent (0), distally convergent (1).

10. Distribution of veins: all veins equidistant (0), lateral veins on each side of the upper glume closely approximate (1).

11. Position of the outer veins: marginal (0), not marginal (1). In most *Paspalum* species epidermal and chlorenchymatous tissues appear more or less expanded into a margin beyond the outer veins. In the *Pectinata* this margin is broad and contributes to the

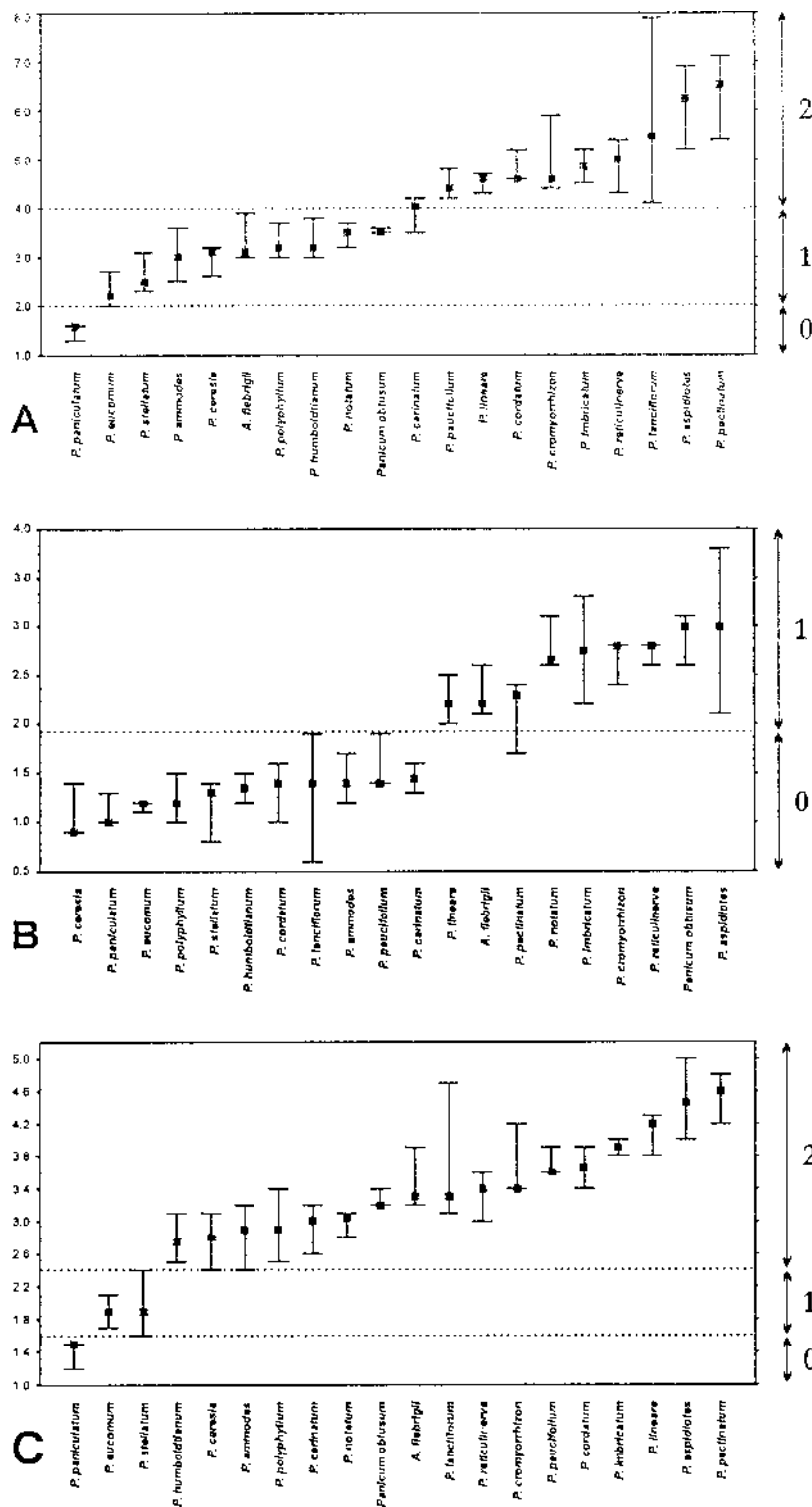

FIG. 1. Observed variation of quantitative characters, arranged following increasing median values. A. Length of the upper glume [mm] (character 2). B. Width of the lower lemma [mm] (character 17). C. Length of the upper floret [mm] (character 30). Vertical bars = ranges; horizontal bars = upper and lower values; black squares = median values; horizontal dashed lines across the diagrams = limits of states, coding for these states is indicated by numbers in the right part of the diagrams.

“winged” appearance of the spikelet (cf. Chase 1939; Rodríguez 1992; Renvoize 1995). In *P. stellatum*, *P. cerasia*, and *P. eucomum* the outer veins are marginal and the only cells observed beyond them are cushion cell surrounding hair bases.

12. Lateral extension of the glume tissues: involute (0), flat (1).
13. Margin scabrousness: smooth (0), scabrous (1).
14. Indumentum of the lateral portion beyond the outer veins: glabrous to scabrous (0), pubescent (1).
15. Apex of the glume: navicular or cucullate (0), flat (1).
16. Upper glume transversely crumpled or wrinkled: absent (0), present (1).

#### Lower lemma.

17. Width: less than 1.9 mm (0), 1.9 or more (1). The studied species are roughly arranged into two non-overlapping groups according to this character (Fig. 1 B).

18. Axillary flower: male (0), absent (1).
19. Dorsum of the lower lemma: flat (0), bowed (1). A flattened lower lemma is a synapomorphic feature of the genus *Paspalum* and contributes to the typical plano-convex shape of *Paspalum* spikelets.
20. Shape of the basal portion: non-auricled (0), auricled, the auricles concrescent with the rachilla (1), auricled, the auricles free (2).
21. A marginal fringe of tuberculate hairs: absent (0), present (1). See discussion of character 5.
22. Indumentum of the abaxial epidermis: glabrous (0), pubescence made of hairs not conspicuously tuberculate at the base (1), pubescence of tuberculate hairs (2). See discussion of character 6.
23. Number of lateral veins on each side of the lemma: one (1), two (2), three (3), four or more (4).
24. Midvein: present (0), lacking (1).
25. Distal convergence of midvein and lateral veins: not convergent (0), distally convergent (1).
26. Lateral extension of the lemma tissues: involute (0), flat (1).
27. Margin indumentum: smooth (0), scabrous to ciliate (1), hairy (2).
28. Indumentum of the lateral portion beyond the outer veins: glabrous (0), pubescent (1).
29. Apex of the lemma: navicular or cucullate (0), flat (1).

#### Upper floret.

30. Length: less than 1.6 mm (0), 1.6–2.4 mm (1), more than 2.4 mm (2). The studied species are arranged into three groups according to this character, although conditions 0 and 1 occur only in the outgroup (Fig. 1 C).

31. Lemma with epidermal papillae: absent (0), present (1). Epidermal papillae on the lemmas and paleas are broadly distributed among grasses, although size, shape, and distribution of them are variable. To avoid “noise” caused by a doubtful scoring of this variation, we only consider as a character the presence or absence of such papillae. Epidermal cells with an inflated outer wall were observed in one specimen of *P. stellatum* (BAA 23261), which are not obviously homologous to the papillose epidermal cells observed in other species. As this condition was detected in no other species and is a polymorphic within *P. stellatum*, inflated epidermal cells were considered non-informative and this species was plainly scored as non-papillose (condition 0). Data from *Panicum obtusum* and *Anthaenantiopsis fiebrigii* were scored according to Zuloaga (1987) and Morrone et al. (1993) respectively.

32. Palea with epidermal papillae: absent (0), present (1). See discussion of character 31.

33. Position of epidermal papillae: eccentric (0), subcentral (1). Epidermal papillae may be notably eccentric, placed near one extreme of long epidermal cells, or may be placed near the middle of relatively short epidermal cells.

34. Subepidermal sclerenchymatous cell layers: one (0), two or more (1). The thickness of the subepidermal sclerenchymatous tissue is one of the features responsible for the “induration” of the upper antherium, as well as the density of epidermal papillae and the thickness of the epidermal cell walls.

35. Abscission of the upper floret at maturity: absent (0), present (1).

36. Apex indumentum: absent (0), present (1).

37. Lemma indumentum: glabrous (0), pubescent (1). Pubescence is specially conspicuous as two rows of hairs along the lemma edges.

38. Palea indumentum: glabrous (0), pubescent (1).

39. Apex of the fertile floret: open (0), closed (1). The upper antherium is closed at apex when the apex of the lemma encloses the palea apex; otherwise the antherium is open.

#### Inflorescence.

40. Occurrence of a spikelet ending the inflorescence main axis: present (0), absent (1). When a terminal spikelet (a “main florescence”) occurs, it is usually accompanied by some short paraclades long the distal portion of the inflorescence main axis.

41. Arrangement of the inflorescence primary branches along the main axis: two or more primary branches along an elongated axis (0), two conjugate “racemes” (1), several (3 or more) fasciculate or digitate “racemes” (2). The primary branches of the *Paspalum* inflorescence are the so-called “racemes”, which are in fact long paraclades bearing spikelets arranged in either a botryoid-like or a thyrsoid-like pattern (cf. Rua and Weberling 1998). The inflorescence primary branches of *Panicum obtusum* and *Anthaenantiopsis fiebrigii* bear also thyrsoid-like arranged spikelets. Conjugate and fasciculate “racemes” occur as a consequence of the shortening of the main axis internodia. Although the occurrence of a solitary “raceme” can represent a case of reduction of either condition 0 or condition 1, no exclusively solitary “racemes” occur among the studied species; thus solitary “racemes” were considered non-informative and the species having them were scored as either 0 or 1 according to the character state definition enunciated above.

42. Pulvinus at the base of the primary branches: glabrous (0), hairy (1). Each inflorescence primary branch bears a pulvinus at its base, which in most cases are more or less pubescent or ciliate.

43. A spikelet ending the primary branches: present and fully developed (0), present but abortive, as well as the distal nodes of the “raceme” (1), absent, the distal spikelets of the “raceme” becoming more and more rudimentary towards the apex (2).

44. Rachis cross section: trigonous (0), laterally expanded into two narrow wings having chlorenchyma between the epidermal layers (1), laterally expanded into two membranous wings having some parenchymatous tissue between the epidermal layers (2), id. but the wings composed only of epidermis (3). According with the usual dorsiventral pattern of the poaceous shoots (cf. Goebel 1884; Cámara-Hernández and Bellón 1992), a trigonous rachis possesses two lateral edges and a ventral one. In most species of *Paspalum*, the rachis of the “racemes” is laterally expanded into two narrow “wings”, whereas the ventral edge appears as a keel along the ventral side of the rachis. Such wings may or may not be edged by a marginal nerve. In species of subgenus *Ceresia* the wings are usually further expanded into two membranes composed only of the two epidermal layers.

45. Indumentum on the rachis surfaces: glabrous (0), scabrous (1), pubescent (2).

46. Spikelet arrangement: paired (0), solitary (1). Whether the spikelets appear single or paired depends on the branching degree of the short paraclades (sPc), i.e. the repetitive spikelet-bearing units along each “raceme” (cf. Weberling et al. 1993). Such short paraclades may be composed each of either a single branch ending in a spikelet (haplostachyous sPc) or two axes of consecutive branching order each of them ending in a spikelet (diplostachyous sPc). In the former case the spikelets appear solitary, in the latter they appear paired.

47. Concrescence of short paracladia branchlets with the rachis: branchlets free or only concrescent with the rachis in their proximal portion, so that the spikelets appear “pedicellate” (0), branchlets almost completely concrescent with the rachis, so that the spikelets appear sessile (1).

48. A crown of hairs at the top of each spikelet-bearing branchlet: absent (0), present (1).

49. Enrichment shoots: absent (0), present (1). Enrichment shoots are branches (“paraclades”) bearing a terminal inflorescence or “flowering unit” (Sell 1969, 1976). When enrichment shoots do not

occur the culm appears unbranched (for more details see Rua and Weberling 1998).

#### Growth habit.

50. Growth direction of the zone of short internodia: orthotropous, forming tussocks (0), shortly plagiotropous, the culms bunched anyway (1), plainly plagiotropous (2). The zone of short internodia is the proximal portion of the tillers, which usually behaves as an innovation zone (Rua and Gróttola 1997). It may be orthotropous, so that the culms are bunched together to form dense tussocks, or shortly plagiotropous so that loose tussocks result. It may also be composed of a series of plagiotropous phytomers which may grow underground to form a rhizome or more rarely spread superficially, as occurs in *P. notatum*.

51. Leaf succession along tillers: the prophyll is followed by some cataphylls (0), the prophyll is immediately followed by foliage leaves (1).

52. Growth direction of the culm: orthotropous to geniculate (0), decumbent (1), rhizomatous (2). The culm is the distal portion of the tillers which bears long internodia. In both decumbent and rhizomatous culms (conditions 1 and 2, respectively) the proximal portion of the culm is plagiotropous, rhizomatous culms being further characterized because their proximal portion grows underground, bears cataphylls and their nodes are rooting.

#### Leaf blade anatomy.

53. Cross section outline: expanded to broadly V-shaped (0), U-shaped to convolute (1), conduplicate (2), elliptical (3). In conditions 0 to 2, the leaves are normally expanded or open but they can exhibit different degrees of infolding. V-shaped and U-shaped leaves have a central keel associated with adaxial colorless parenchyma, which is strikingly thick in relation to the rest of the leaf blade. Conduplicate leaves bear a group of bulliform cells in the middle upon the median vascular bundle and no development of colorless parenchyma. Condition 3 included permanently acicular and solid leaves, with colorless parenchyma in the middle and adaxial epidermis undiscernible or reduced.

54. Leaf blade surface: smooth (0), furrowed (1).

55. Vascular bundles below bulliform cells: up to three (0), numerous (1).

56. Secondary and tertiary foliar vascular bundles: differentiated (0), undifferentiated (1).

57. Distribution of bulliform cells: not grouped (0), grouped (1). Bulliform cells may be present throughout the whole adaxial epidermis or restricted to regular and well-defined groups.

58. Colorless parenchyma associated to bulliform cells: absent (0), present (1).

59. Abaxial epidermal cells: superficially flat (0), papillar or inflated (1).

60. Adaxial epidermal cells: superficially flat (0), papillar or inflated (1).

#### Ligule.

61. Ligular basis: straight to slightly bowed (0), strongly bowed to ogival (1), U-shaped (2).

62. Hairs behind the ligule: absent (0), a fringe of short hairs (1), a tuft of long hairs (2). Behind the membranous ligule a fringe of hairs sometimes occur, which may be either roughly as long as the ligule or remarkably longer.

63. Ligule development: well developed, conspicuous (0), very brief, inconspicuous (1).

#### Leaf sheath.

64. Adaxial surface pigmentation: greenish (0), brown (1).

65. Intercellular air spaces between vascular bundles: absent (0), present (1).

**Data Analysis.** A cladistic analysis based on maximum parsimony (Farris 1983) was performed with the program NONA ver. 1.8 (Goloboff 1998a) using equal character weights. Due to the high number of terminals a heuristic search strategy was adopted. All multistate characters were treated as nonadditive. The analysis was performed using the following settings and commands: amb-

(only unambiguous support, collapsing branches when the set of possible states of the ancestral node and the set of possible states of the descendant node share at least one character state); mult\*20 (randomizes the order of taxa in the matrix, and creates a Wagner tree which is submitted to 'tree bisection and reconnection' (TBR) swapping holding a maximum of 20 trees, than repeats this process 20 times); max\* (TBR swapping of trees found by mult\*20).

Separate analyses using implied weights (Goloboff 1993) were carried out with Pee-Wee ver. 2.9 (Goloboff 1998b) using the same search strategies as in NONA. In cases of character conflicts, PeeWee downweights homoplasious characters in proportion to their amount of extra steps (homoplasy). The strength with which a homoplasious character is downweighted by PeeWee depends on the concavity of the weighting function. Six different concavities are available in the program, 6 being the mildest and 1 the strongest weighting function (Goloboff 1998b). All six concavities were explored and will hereafter be referred to as conc 1-6.

In an attempt to detect possible islands (Maddison 1991), the shortest trees obtained from both equal-weight and implied-weight analyses were submitted to 10,000 iterations of Parsimony Ratchet (Nixon 1999a) using the nixwts\* option of Nona/PeeWee (TBR, ratchet factor 20%, maximum starting trees=1).

Bremer support (BS) (Bremer 1994) was calculated using the command bsupport of NONA and Pee-Wee (applied to suboptimal trees found in previous searches with the find\* command), which expresses the decay index in steps and in units of 'fit' respectively. Jackknife group frequencies (JGF) (Farris et al. 1996) were calculated by NONA using the file jak.run distributed together with the program (1,000 iterations, randomly deleting 36% of the characters, search option mult\*5) and the program fq.exe, which calculates a majority rule consensus tree of the output (cf. Goloboff 1998a,b). Tree drawings were produced using Winclada (Nixon 1999b).

## RESULTS

When the data matrix was analyzed using equally weighted characters, two equally parsimonious trees were found, each 185 steps long (CI=0.44, RI=0.63). Searches using parsimony ratchet yielded no additional trees. In both trees (Fig. 2 A) *Panicum obtusum* appears as sister taxon of a moderately well supported genus *Paspalum* (JGF = 68; BS = 2). Within *Paspalum*, *P. ammodes*, *P. paucifolium*, and *P. paniculatum* successively diverge before a weakly supported (JGF < 50; BS = 1) major clade emerges, which comprises all studied species belonging to the subgenus *Ceresia* plus *P. notatum*, *P. cromyorrhizon*, and *P. lineare*. Within this clade, *P. humboldtianum*-*P. polyphyllum* (JGF = 80; BS = 3) appear as sister taxa to a weakly supported clade containing the remaining species included in the analyses. In this clade, *P. notatum*-*P. cromyorrhizon*-*P. lineare* (JGF = 52; BS = 2) are sister to the remainder of the subgenus *Ceresia* (JGF = 50; BS = 1).

Section *Pectinata* appears as a strongly supported monophyletic group (JGF = 90; BS = 5), with *P. ceresia* as sister group. Within sect. *Pectinata*, *P. lanciflorum* is placed as sister taxon to a clade (JGF = 91; BS = 6) containing the other five species. All resolved topologies within this clade are weakly supported. *P. aspidotes* is placed as sister to the remaining four species, which were arranged in two equally parsimonious topologies, either with *P. reticulinerve*-*P. pectinatum* forming a sister clade of *P. imbricatum*-*P. cordatum*, or with



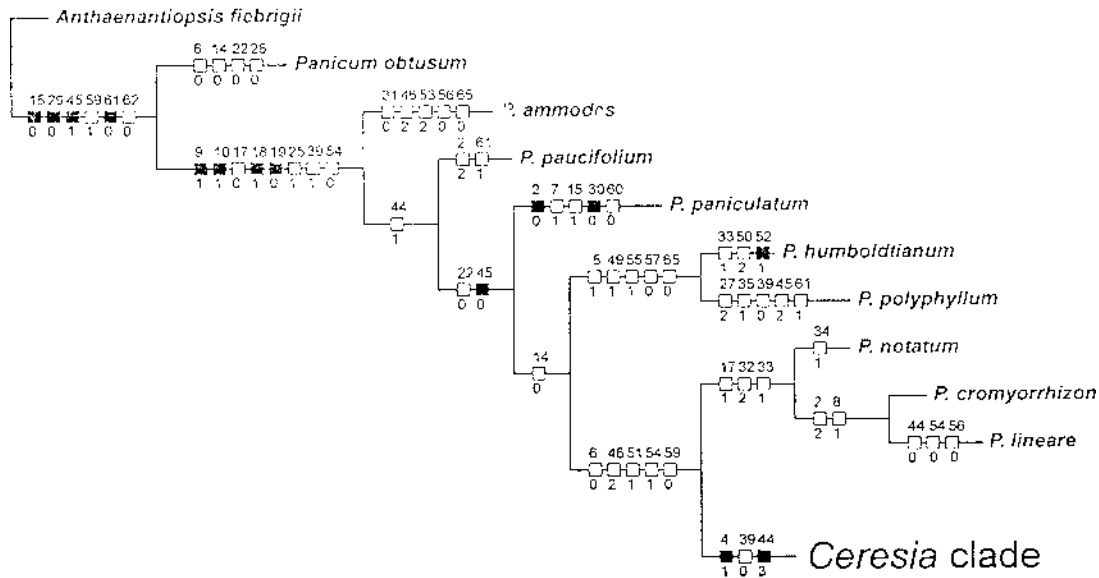

Ceresia clade

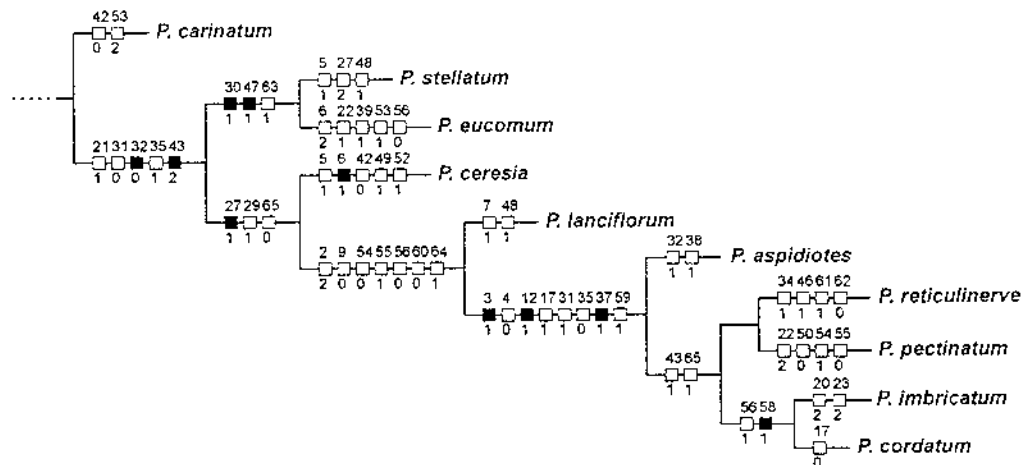

FIG. 3. One of the two most parsimonious trees found by NONA, showing character state changes along branches; black squares represent non-homoplasious changes, white squares represent homoplasious changes, the gray square represent an ambiguously homoplasious/non-homoplasious change. Figures above branches indicate character numbers, figures below branches indicate character states.

*stellatum*-*P. eucomum* rather than sister to sect. *Pectinata* (Fig. 2 B), and by producing a different arrangement of *P. notatum*, *P. cromozyrrhizon*, and *P. lineare*. Searches with conc 2 to 6 result in the same topologies, whereas searches with conc 1 yield slightly different cladograms but retain the same ingroup topologies (trees not shown).

DISCUSSION

**Monophyly of Paspalum Sect. Pectinata.** The present analyses confirm the monophyly of *Paspalum* sect.

*Pectinata*, which is unambiguously supported by characters 2, 9, 54, 55, 56, 57, 60, and 64 (Fig. 3). Nevertheless, none of these characters is unique to sect. *Pectinata*. The more obvious character usually taken into consideration for diagnosing this section (cf. Renvoize 1995) is the occurrence of imbricate spikelets, which in fact results from the combination of three quantitative features: large spikelets, short internodia between consecutive spikelets, and a small angle between "raceme" axis and spikelet axis. Of these features, only 'length of spikelets' (here expressed as 'length of the

upper glume', character 2) follows a nearly discontinuous distribution (Fig. 1 A) and can be used as a character with little hesitation. Although this character is synapomorphic for sect. *Pectinata*, it is paralleled by *P. cromyorrhizon*.

Another character usually considered diagnostic for sect. *Pectinata* is a winged, cordate upper glume (Rodríguez 1992; Renvoize 1995), which is, in fact, a synapomorphy of the clade formed by all species of sect. *Pectinata* except *P. lanciflorum* (see below). Solitary spikelets (Rodríguez 1992) occur within sect. *Pectinata* in all species except *P. reticulinerx*, and is a common feature in many *Paspalum* species outside this section.

Conversely, some new diagnostic characters can be identified from our analysis: an upper glume with non-convergent midvein and lateral veins (character 9), a flat outer wall of the leaf blade adaxial epidermal cells (character 60), and a brownish internal surface of the leaf sheath (character 64). A scabrous margin of the upper glume (character 13) is also unique to sect. *Pectinata*; however, this character is not shown as a synapomorphy in Fig. 3 because of the ambiguous optimization caused by its inapplicability in *P. ceresia*, *P. eucomum*, and *P. stellatum*.

**Phylogenetic Relationships Within Sect. *Pectinata*.** Within sect. *Pectinata*, *P. lanciflorum* is consistently placed as sister taxon to a well supported clade containing all the remaining species. This clade is supported by characters 3, 4, 12, 17, 20, 31, 35, 37, and 59. A basally auriculate or cordate upper glume (character 3), a laterally flattened or winged upper glume (character 12), and a pubescent upper lemma (character 37) are unique to this clade. As stated above, characters 3 and 12 have been taken as diagnostic for sect. *Pectinata* as a whole (Rodríguez 1992; Renvoize 1995).

Further resolution within this clade is weakly supported, including the placement of *P. aspidiotes* as sister to the rest of the species as well as the grouping of *P. imbricatum* with *P. cordatum* (Fig. 2A).

**Taxonomic Placement and Sister Group Relationships of Sect. *Pectinata*.** Inclusion of section *Pectinata* within *Paspalum* subg. *Ceresia* is confirmed by the present analyses, although the monophyly of subgenus *Ceresia* itself is weakly supported (see next paragraph). Two alternative sister group relationships of sect. *Pectinata* result from our analyses. Analysis using equal weights yields a topology in which a poorly supported clade appears that includes *P. ceresia* as sister taxon of sect. *Pectinata* (Fig. 2 A). When implied weights are used, a weakly supported clade arises as sister group of the *Pectinata*-clade, which includes *P. ceresia* as basal branch to a well supported subclade composed of *P. stellatum* and *P. eucomum* (Fig. 2 B). A more comprehensive sampling of species within the subgenus *Ceresia* is necessary to address this issue.

**Taxonomic Circumscription of *Paspalum* Subg.**

***Ceresia*.** As mentioned above, a poorly supported clade results that comprises all species of *Paspalum* subg. *Ceresia* included in our analyses but *P. humboldtianum* and *P. polyphyllum* (see discussion below). This clade (hereafter the "*Ceresia* clade") is supported by characters 4, 39, and 44 (Fig. 3). A winged rachis is the most conspicuous feature of subgenus *Ceresia*, although this character also occurs in species outside this subgenus (groups *Racemosa*, *Dissecta*, and *Gardneriana*, cf. Chase 1929, 1939; Renvoize 1972; Morrone et al. 1995, 1996), as well as in the related genera *Thrasya* (Burman 1985), *Thrasypopsis* (Parodi 1946), and *Mesosetum* (Filgueiras 1989). A tuft of hairs at the base of the upper glume (character 4) appears as a synapomorphy of the *Ceresia* clade, but is reversed within sect. *Pectinata*. Fertile florets open at the apex (character 39) are also synapomorphic of the *Ceresia* clade, with a reversion in *P. eucomum*; this character also occurs in other genera of the *Panicaceae*.

Within the *Ceresia* clade, *P. carinatum* appears as basal in all resolutions. This is internally resolved as described in the previous paragraph, i.e., either into a clade containing *P. stellatum* and *P. eucomum* and a clade containing *P. ceresia* and sect. *Pectinata* (equal-weight analysis), or into a clade containing *P. ceresia*, *P. stellatum*, and *P. eucomum* and other corresponding to sect. *Pectinata* (implied-weight analysis). Our results suggest the necessity of redefining *Paspalum* subg. *Ceresia* by excluding *P. humboldtianum* and *P. polyphyllum* (and perhaps other related species), although a taxonomic resolution in this sense would be delayed until a more comprehensive analysis (including all species of subgenus *Ceresia* and a more extensive sampling of the outgroup) have been carried out.

**Taxonomic Placement of *P. humboldtianum* and *P. polyphyllum*.** As mentioned above, the inclusion of *P. humboldtianum* and *P. polyphyllum* within subgenus *Ceresia* is not supported by our analyses. Moving *P. humboldtianum* + *P. polyphyllum* to the *Ceresia* clade implies at least four additional steps. Both species were included in subg. *Ceresia* by previous authors (Chase 1929, 1939; Pilger 1940; Rodríguez 1998, see above under "Outgroup taxa") on the basis of their hair-fringed spikelets, but this character is not shared by most *Ceresia* species. Moreover, the inclusion of *P. humboldtianum* + *P. polyphyllum* makes the diagnosis of subgenus *Ceresia* ambiguous because no unique synapomorphies define the taxon. A placement of *P. humboldtianum* and *P. polyphyllum* near *P. paucifolium*, as suggested by Parodi and Nicora (1966), is not supported by our analysis.

**ACKNOWLEDGEMENTS.** This research was supported by the Universidad de Buenos Aires (Grants UBACyT TG-043 and JG-21) and the Consejo Nacional de Investigaciones Científicas y Técnicas (Grant PIP 0342). We are indebted to the Curators of the herbaria that made the material available, to L. M. Giussani, who kindly



make unpublished data available to us, to G. E. Zaslavsky for histological preparations, and to L. Aagesen, O. Morrone, R. D. Tortosa, F. O. Zuloaga, and two anonymous reviewers for helpful criticism.

## LITERATURE CITED

- BARRETO, I. 1974. O gênero *Paspalum* (Gramineae) no Rio Grande do Sul. Tese de Livre Docência do Departamento de Fitotecnia da Faculdade de Agronomia da Universidade Federal do Rio Grande do Sul, Porto Alegre.
- BREMER, K. 1994. Branch support and tree stability. *Cladistics* 10: 295–304.
- BRUMMITT, R. K. and C. E. POWELL. 1992. *Authors of plant names*. Kew: Royal Botanic Gardens.
- BURMAN, A. G. 1985. The genus *Thrasya* H.B.K. (Gramineae). *Acta Botanica Venezuelica* 14(4): 7–93.
- CÁMARA-HERNÁNDEZ, J. and R. BELLÓN. 1992. Dorsiventrality in the inflorescence and vegetative axes of *Zea diploperennis* (Poaceae). *Beiträge zur Biologie der Pflanzen* 67: 59–72.
- CHASE, A. 1929. The North American species of *Paspalum*. Contributions from the United States National Herbarium 28: 1–310.
- . 1939. Monograph of the genus *Paspalum*. Unpublished manuscript, Hitchcock & Chase Library, Smithsonian Institution, Washington.
- CLAYTON, W. D. and S. A. RENVOIZE. 1986. *Genera Graminum*. Kew Bulletin, Additional Series 13: 1–389. London: Her Majesty's Stationery Office.
- DAVIDSE, G. and R. W. POHL. 1974. Chromosome numbers, meiotic behavior, and notes on tropical American grasses (Gramineae). *Canadian Journal of Botany* 52: 317–328.
- FARRIS, J. S. 1983. The logical basis of phylogenetic analyses. Pp. 7–36 in *Advances in cladistics*, Vol. 2, eds. N. Platnick and V. Funk. New York: Columbia University Press.
- , V. A. ALBERT, M. KÄLLERSJÖ, D. LIPSCOMB, and A. G. KLUGE. 1996. Parsimony jackknifing outperforms neighbor-joining. *Cladistics* 12: 99–124.
- FILGUEIRAS, T. S. 1989. Revisión de *Mesosetum* Steudel (Gramineae: Paniceae). *Acta Amazonica* 19: 47–114.
- GIUSSANI, L. M., H. COTA-SÁNCHEZ, F. O. ZULOAGA, and E. A. KELLOGG. In press. A molecular phylogeny of the grass subfamily Panicoideae (Poaceae) shows multiple origins of C4 photosynthesis. *American Journal of Botany*.
- GOEBEL, K. 1884. Beiträge zur Entwicklungsgeschichte einiger Inflorescenzen. *Jahrbücher für wissenschaftliche Botanik* 14: 1–42 + Tafel I–IV.
- GOLOBOFF, P. A. 1993. Estimating character weights during tree search. *Cladistics* 9: 83–91.
- . 1998a. NONA ver. 1.9. Computer program and documentation, New York.
- . 1998b. Pee-Wee ver. 2.9. Computer program and documentation, New York.
- GÓMEZ-MARTÍNEZ, R. and A. CULHAM. 2000. Phylogeny of the subfamily Panicoideae with emphasis on the tribe Paniceae: evidence from the trnL-F cpDNA region. Pp. 136–140 in *Grasses: systematics and evolution*, eds. S. W. L. Jacobs and J. Everett. Melbourne: CSIRO.
- HOLMGREN, P. K., N. H. HOLMGREN, and L. C. BARNETT. 1990. *Index Herbariorum. Part I: The Herbaria of the World*. *Regnum Vegetabile* 120: 1–693.
- JUDZIEWICZ, E. J. 1990. Poaceae (Gramineae). In *Flora of the Guianas*, ed. A. R. A. Görts-van Rijn. Königstein: Koelt.
- KORNET, D. J. and H. TURNER. 1999. Coding polymorphism for phylogeny reconstruction. *Systematic Biology* 48: 365–379.
- MADDISON, D. 1991. The discovery and importance of multiple islands of most parsimonious trees. *Systematic Zoology* 40: 315–328.
- METCALFE, C. R. 1960. *Anatomy of the Monocotyledons. I. Gramineae*. Oxford: Clarendon.
- MORRONE, O., T. S. FILGUEIRAS, F. O. ZULOAGA, and J. DUBCOVSKY. 1993. Revision of *Anthaenantiopsis* (Poaceae: Panicoideae: Paniceae). *Systematic Botany* 18: 434–453.
- , A. S. VEGA, and F. O. ZULOAGA. 1996. Revisión de las especies del género *Paspalum* (Poaceae: Panicoideae: Paniceae), grupo *Dissecta*. *Candollea* 51: 103–138.
- , F. O. ZULOAGA, and E. CARBONÓ. 1995. Revision of *Anthaenantiopsis* (Poaceae: Panicoideae: Paniceae). *Annals of the Missouri Botanical Garden* 82: 82–116.
- NIXON, K. C. 1999a. The Parsimony Ratchet, a new method for rapid parsimony analysis. *Cladistics* 15: 407–414.
- . 1999b. Winclada (BETA) ver. 0.9.9. Ithaca: published by the author.
- and J. M. CARPENTER. 1993. On outgroups. *Cladistics* 9: 413–426.
- PARODI, L. R. 1946. Nuevo género de gramíneas del Brasil. *Boletín de la Sociedad Argentina de Botánica* 1: 293–297.
- and E. G. NICORA. 1966. Apuntes para una monografía del género *Paspalum*. Unpublished manuscript, Library of the "Laboratorios de Botánica Lorenzo R. Parodi", Facultad de Agronomía, Universidad de Buenos Aires.
- PILGER, R. K. F. 1940. Gramineae, Panicoideae. Pp. 1–208 in *Die natürlichen Pflanzenfamilien* ed. 2, 14e, eds. A. Engler and K. Prantl. Leipzig: Wilhelm Engelmann.
- POHL, R. W. 1980. Family #15, Gramineae. Pp. 1–608 in *Flora Costaricensis*, ed. W. Burger. Fieldiana Botany, New Series, 4.
- RENVOIZE, S. A. 1972. Studies in the Gramineae: XXX. *Kew Bulletin* 27: 451–455.
- . 1995. A new species of *Paspalum* (Gramineae) from Bolivia. *Kew Bulletin* 50: 339–341.
- RODRÍGUEZ, H. 1992. *Pectinata* Chase ex Rodríguez, nueva sección en el género *Paspalum* L. (Gramineae). *Ernstia* 2: 21–23.
- . 1998. El subgénero *Ceresia* (Pers.) Reichenb., del género *Paspalum* L. (Gramineae) en Venezuela. *Ernstia* 8: 7–50.
- RUA, G. H. and M. C. GRÓTTOLA. 1997. Growth form models within the genus *Paspalum* L. (Poaceae, Paniceae). *Flora* 192: 65–80.
- and F. WEBERLING. 1998. Growth form and inflorescence structure of *Paspalum* L. (Poaceae, Paniceae): a comparative morphological approach. *Beiträge zur Biologie der Pflanzen* 69: 363–431.
- SELL, Y. 1969. Les complexes inflorescentiels de quelques Acanthacées. Étude particulière des phénomènes de condensation, de racémisation, d'homogénéisation et de troncation. *Annales des Sciences Naturelles, Botanique, Paris*, 12e. Série, 10: 225–350.
- . 1976. Tendances évolutives parmi les complexes inflorescentiels. *Revue générale de Botanique* 83: 247–267.
- SWALLEN, J. R. 1967. New species of *Paspalum*. *Phytologia* 14: 358–389.
- WEBERLING, F., U. MÜLLER-DOBLIES, and D. MÜLLER-DOBLIES. 1993. Zur deskriptiven und vergleichendmorphologischen Terminologie komplexer Infloreszenzen. *Beiträge zur Biologie der Pflanzen* 67: 453–473.
- ZULOAGA, F. O. 1987. Systematics of New World Species of *Panicum* (Poaceae: Paniceae). Pp. 287–306 in *Grass systematics and evolution*, eds. T. R. Soderstrom, K. W. Hilu, C. S. Campbell, and M. E. Barkworth. Washington D. C.: Smithsonian Institution.

## APPENDIX 1. EXAMINED MATERIAL.

*Anthaenantiopsis fiebrigii* Parodi. Cabrera 9149 (BAA), Cabrera & Schwabe 202 (BAA), Fabris 8215 (BAA), Parodi 14714 (BAA).  
*Panicum obtusum* Kunth. Gould 2889 (BAA), Griffiths

6800 (BAA), Harvey 1630 (BAA), Johnston 7419 (BAA), Lundell & Lundell 14350 (BAA), Tharp 10 (BAA), 4138 (BAA).

*Paspalum ammodes* Trin. Macedo 1384 (BAA), 1388 (BAA), Morello s.n. (BAA), Rojas 3945 (BAA), 6316 (BAA), 6316a (BAA), Souza 3016 (BAA).

*Paspalum aspidiotes* Trin. Berry et al. 4975 (MO), C. Calderón et al. 2760 (MO), Davidse et al. 1986 (MO), Davidse & Huber 22726 (MO), Fraser 370 (US), Huber 3598 (MO), 4380 (MO), 12032 (MO), Huber et al. 9898 (US), Mostacedo et al. 1862 (CTES), 2115 (USZ, MO), Prance et al. 29114 (MO), Riedel 1048 (B), Steyermark et al. 113165 (MO), 117852 (MO).

*Paspalum carinatum* Humb. et Bonpl. ex Flüggé. Arbo et al. 5185 (CTES), Chase 9001 (BAA), Fróes 23632 (BAA), Hatschbach et al. 60212 (CTES), Joly 291 ABJ (BAA), 582 ABJ (BAA), Macedo 1397 (BAA), 4405 (BAA), 4421 (BAA), 4438 (BAA), Pires et al. 6317 (BAA), Rawitscher 16 (CTES).

*Paspalum ceresia* (Kuntze) Chase. Adamoli 15847 (BAA), 15859 (BAA), coll. unknown s.n. (BAA 17003), Fiebrig 2664 (BAA), Hitchcock 22825 (BAA), Jiménez 6 (BAA), Mandon 1255 (BAA), Meyer 21686 (BAA), Ochoa 1043 (BAA), Parodi 14654 (BAA), Quarín 3949 (BAA), Rua & Aagesen 314 (BAA), 327 (BAA), Schreiter 9256 (BAA), Steinbach 16796 (BAA), Türpe 2832 (BAA).

*Paspalum cordatum* Hack. Araujo 155 (BAA), Brade 19638 (US), Davidse & González 14272 (MO), 14651 (MO), Dusén 9109 (US), 16174 (BAA, SI, US), Hatschbach 43507 (MO), Kral et al. 75981 (MO), Kummrow & Stutts 1743 (MO), Löfgren 1105 (B), s.n. (US), Macedo 1489 (BAA), 1543 (BAA, US), Oliveira 303 (MO), Saint Hilaire 1368 (US), Smith et al. 14438 (SI), 14579 (MO, SI), 14858 (MO), Usteri 9753 (US), Valls s.n. (BAA), Weddell 1699 (US).

*Paspalum cromyorrhizon* Trin. ex Döll. Cusato et al. 1191 (BAA), da Costa Sacco 232 (BAA), 233 (BAA), Faggi et al. s.n. (BAA 14029), Gallinal et al. PE-4609 (BAA), Parodi 12671 (BAA), Quarín 1676 (BAA), 3222 (BAA), 3849 (BAA), 4039 (BAA), Rosengurtt B-3111 (BAA), B-3666 (BAA), B-4284 (BAA), B-6950 (BAA).

*Paspalum eucomum* Nees ex Trin. Araujo 165 (BAA), Chase 9097 (BAA), Macedo 1818 (BAA).

*Paspalum humboldtianum* Flüggé. Anderson & Vera 2039 (BAA), Cabrera 12168 (BAA), Cabrera et al. 13883 (BAA), 15538 (BAA), Covas 1143 (BAA), Nicora 246 (BAA), Osten 13140 (BAA), Parodi 8078 (BAA), 9782 (BAA), 11056 (BAA), 13474 (BAA), Peirano 662 (BAA), Rua & Aagesen 315 (BAA), 328 (BAA), 356 (BAA), Sayago 3078 (BAA), Sleumer & Verveorst 2813 (BAA), Valencia 2331 (BAA), Vallejos 74 (BAA).

*Paspalum imbricatum* Filg. Filgueiras 1040 (B), 3317 (US).

*Paspalum lanciflorum* Trin. Berry 530 (MO), BoometGrillo 6288 (MO), Callejas & Marulanda 6886

(MO, SI), 6894 (MO), Cardona 2225 (MO), Cavalcante 849 (US), da Silva et al. 1873 (MO), Davidse 4697 (BAA, MO), Davidse & González 14170 (MO), Davidse & Huber 15011 (MO), 22560 (MO), 22770 (MO), 22833 (MO), 22995 (MO), 23108 (MO), 23121 (MO), Davidse & Llanos 5146 (MO), Delgado 1217 (MO), Elcoro 243 (MO), Galen Smith & Idrobo 1568 (MO, BAA), Goodland 923 (US), Harrison 1403 (US), Heringer et al. 4491 (US), Hermoso s.n. (MO), Huber 655 (MO), 1208 (MO), 2177 (MO), 2208 (MO), 2275 (MO), 2324 (MO), 2375 (MO), 2399 (MO), 2661 (MO), 4239 (MO), 4363 (MO), 4415 (MO), 4587 (MO), 4617 (MO), 4658 (MO), 9850 (MO), 10948 (MO), Huber et al. 6781 (MO), Irwin et al. 21579 (MO, US), Killeen et al. 4929 (USZ, MO), Liesner 19350 (MO, SI), 24197 (US), Maguire 33171 (US), 33663 (US), McDowell & Gopaul 2725 (US), Philcox & Fereira 4387 (US), Pires et al. 6134 (BAA), 6191 (BAA), Pires & Black 2232 (US), Plowman et al. 8952 (US), 8956 (MO, US), 9132 (US), 9201 (MO, US), Pohl 1454 (B), Ratter et al. 849 (MO), Rua et al. 253 (BAA), Steyermark 105137 (MO), Steyermark et al. 112243 (MO), 117560 (MO), Steyermark & Carreño Espinosa 117859 (MO), Zuloaga et al. 4413 (MO).

*Paspalum lineare* Trin. Araujo 162 (BAA), Hassler 10775a (BAA), Hatschbach 2058 (BAA), 3451 (BAA), 4196 (BAA), Joly 591 ABJ (BAA), Macedo 4703 (BAA), Parodi 4703 (BAA), 4714 (BAA), Quarín 4042 (BAA), Rojas 6393 (BAA), 6411 (BAA), Rua & Carrión 452 (BAA), Schessl 3431b (BAA), Souza 3010 (BAA).

*Paspalum notatum* Flüggé. Berro 5679b (BAA), Calderón 1668 (BAA), Castellanos 18730 (BAA), Ibarrola 5235 (BAA), Orihuela s.n. (BAA 11334), Parodi 3076 (BAA), 13549 (BAA), 14306 (BAA), 14712 (BAA), Rosengurtt 11258 (BAA), Rua et al. 276 (BAA), 283 (BAA), 290 (BAA), Ruiz 375 (BAA).

*Paspalum paniculatum* L. Carnevali 3364 (BAA), 3381 (BAA), Chebataroff 6017 (BAA), Hatschbach 3573 (BAA), Honfi 66 (BAA), Macedo 2215 (BAA), Meyer 687 (BAA), Montes 11226 (BAA), Nicora & Cámara Hernández s.n. (BAA 675), Quarín 315 (BAA), Rambo 54992 (BAA), Tressens et al. 1186 (BAA), Villamil & Martínez s.n. (BAA 12812).

*Paspalum paucifolium* Swallen. Burkart 20571 (BAA), Burkart & Crespo 22910 (BAA), Martínez Crovetto 8475 (BAA), Millán 364 (BAA), Nicora 5707 (BAA), 5812 (BAA), 6239 (BAA), Parodi 3024 (BAA), Pedersen 4503 (BAA), 4552 (BAA), Quarín 3028 (BAA), Rosengurtt B-5748 (BAA), Rua et al. 313 (BAA).

*Paspalum pectinatum* Nees ex Trin. Aparecida da Silva 1055 (CTES), Araujo 27 (BAA), 104 (SI), Azevedo & Lopes 453 (CTES), Dusén 10613 (BAA), 13256 (SI), 16057 (BAA), Fariñas et al. 558 (BAA), Filgueiras 2455 (CTES), 2459 (CTES), Filgueiras & Alvarenga 3162 (CTES), Filgueiras & Lopes 2425 (CTES), Glaziou 22426 (BAA), Irwin & Soderstrom 6758 (SI), 6806 (SI), 7036 (SI), 7162 (SI), Joly 575 ABJ (BAA), Krug et al. s.n.

(BAA), Machado de Campos 111 (BAA), Mostacedo et al. 780 (BAA, USZ), Rojas 6230 (BAA), 6230a (BAA), Valls s.n. (BAA).

*Paspalum polyphyllum* Nees ex Trin. Araujo 195 (BAA), 279 (BAA), 93a (BAA), Arechavaleta 5054 (BAA), Arrillaga et al. 1071 (BAA), Barreto 74 (BAA), 535 (BAA), da Costa Sacco 133 (BAA), Dedecca 302 (BAA), Dusén 14489 (BAA), Felippone 451 (BAA), Hassler 9380 (BAA), Hatschbach 1903 (BAA), 3029 (BAA), Honfi 98 (BAA), Joly 400 ABJ (BAA), Krapovickas et al. 23351 (BAA), 25203 (BAA), Machado de Campos 192 (BAA), Martínez Crovetto 9410 (BAA), Meyer 2090 (BAA), Meyer et al. 20595 (BAA), Parodi 5471 (BAA), Pedersen 5848 (BAA), Quarín et al. 2226 (BAA), Rambo 53906 (BAA), 54991 (BAA), Ramírez 506 (BAA), Rojas 5101 (BAA), 5299 (BAA), 6703 (BAA), 13221 (BAA), Rosengurt B-5750 (BAA), B-5790 (BAA),

B-7690 (BAA), Rua & Aagesen 316 (BAA), Rua et al. 189 (BAA), 191 (BAA), Schinini et al. 23621 (BAA), Steinbach 6808 (BAA), 16789 (BAA).

*Paspalum reticulinerve* Renvoize. Guillén & Choré 1530 (MO), Gutiérrez et al. 1400 (MO), Killeen et al. 4824 (MO, USZ), Rua & Carrión 440 (BAA), Solomon 17003 (LPB).

*Paspalum stellatum* Humb. et Bonpl. ex Flüggé. Arbo et al. 931 (BAA), Burkart & Gamarro 21610 (BAA), Cabral 131 (BAA), Carnevali 3124 (BAA), 3379 (BAA), Jørgensen 14042 (BAA), Montes 16250 (BAA), Nicora 5875 (BAA), 6165 (BAA), Norrmann et al. 159 (BAA), Parodi 5476 (BAA), 7070 (BAA), Pedersen 3783 (BAA), Rojas 2757 (BAA), 7534 (BAA), 9605 (BAA), 13211 (BAA), Rosengurt B-5749 (BAA), B-7358 (BAA), Rua & Aagesen 371 (BAA), 373 (BAA), Rua et al. 188 (BAA), 192 (BAA), 285 (BAA), Rua & Lavia 405 (BAA), Schessl s.n. (BAA), Schinini 6207 (BAA).

APPENDIX 2. Data matrix. Characters and character states are listed and briefly discussed in the text. Question marks indicate unavailable data, dashes indicate inapplicable ones.

	1	2	3	4	5	6	7	8	9	10	11	12	13	14	15	16	17	18	19	20	21	22	23	24	25	26	27	28	29	30	31	32	
<i>Anthrenantiopsis fiebrigii</i>	1	1	0	0	0	2	[2 3]	1	0	0	1	0	0	1	1	0	1	0	1	0	0	2	[2 3]	0	0	0	1	0	1	1	2	1	1
<i>Panicum obtusum</i>	0	1	0	0	0	0	[3 4]	0	0	0	1	0	0	0	0	1	0	1	0	0	0	0	[3 4]	0	0	1	0	0	0	2	1	1	
<i>Paspalum ammodens</i>	2	1	0	0	0	2	2	1	1	1	1	0	0	1	0	0	0	1	0	0	0	2	2	0	1	1	0	1	0	2	0	1	
<i>Paspalum paucifolium</i>	2	2	0	0	0	2	[2 3]	0	1	1	1	0	0	1	0	0	0	1	0	0	0	2	1	0	1	1	0	1	0	2	1	1	
<i>Paspalum paniculatum</i>	2	0	0	0	0	2	1	0	1	—	1	0	0	1	1	0	0	1	0	0	0	0	1	0	1	1	0	0	0	1	1	1	
<i>Paspalum cromyorrhizon</i>	2	2	0	0	0	2	1	1	1	—	[0 1]	0	0	0	0	1	1	1	0	0	0	0	2	0	1	1	0	0	[0 1]	0	0	1	1
<i>Paspalum notatum</i>	2	1	0	0	0	0	2	0	1	1	1	0	0	0	0	1	1	1	0	0	0	0	2	0	1	1	0	0	0	2	1	1	1
<i>Paspalum lineare</i>	2	2	0	0	0	0	[2 3]	1	1	1	[0 1]	1	0	0	0	1	1	1	0	0	0	0	2	0	1	1	0	0	0	2	1	1	1
<i>Paspalum lanciflorum</i>	2	2	0	1	0	0	1	0	0	—	1	0	1	0	1	0	0	1	0	0	1	[0 1]	1	0	0	0	1	0	1	2	0	0	0
<i>Paspalum aspidiotes</i>	2	2	1	0	0	0	2	0	0	1	1	1	1	0	1	0	1	1	0	2	0	0	1	0	1	0	1	0	1	2	1	1	1
<i>Paspalum reticulinerre</i>	2	2	1	0	0	0	[2 3]	0	0	1	1	1	1	0	1	0	1	1	0	1	0	0	[1 2]	0	0	0	1	0	1	2	1	0	[0 1]
<i>Paspalum imbricatum</i>	2	2	1	0	0	0	2	0	0	1	1	1	1	0	1	0	1	1	0	2	0	2	0	0	0	0	1	0	1	2	1	0	0
<i>Paspalum pectinatum</i>	2	2	1	0	0	0	2	0	0	1	1	1	1	0	1	0	1	1	0	1	1	2	1	0	0	0	1	0	1	2	1	0	0
<i>Paspalum cordatum</i>	2	2	1	0	0	0	[2 3]	0	0	1	1	1	1	0	1	0	1	1	0	1	1	[0 2]	1	0	0	0	1	0	1	2	1	0	0
<i>Paspalum carinatum</i>	2	[1 2]	0	1	0	0	2	0	1	1	1	0	0	0	1	0	0	1	0	0	0	0	1	0	1	1	0	0	0	2	1	1	0
<i>Paspalum stellatum</i>	2	1	0	1	1	1	2	0	1	1	0	—	—	—	0	0	0	1	0	0	0	0	1	1	1	1	1	—	—	—	—	—	0
<i>Paspalum ceresia</i>	2	1	0	1	1	1	2	0	1	1	0	—	—	—	1	0	0	1	0	0	1	0	1	1	1	1	1	0	1	2	0	0	0
<i>Paspalum humboldtianum</i>	2	1	0	0	1	2	2	0	1	1	1	0	0	0	0	0	0	1	0	0	0	0	[1 2]	0	1	1	0	0	0	2	1	1	1
<i>Paspalum polyphyllum</i>	2	1	0	0	1	2	2	0	1	1	1	0	0	0	0	0	0	0	1	0	0	[0 3]	1	0	1	1	1	2	0	2	1	1	1
<i>Paspalum eucomum</i>	2	1	0	1	0	2	2	0	1	1	0	—	—	—	0	0	0	0	1	0	1	1	1	[0 1]	1	—	0	0	1	0	1	0	0

