

# Author's Accepted Manuscript

Validation of the Monte Carlo model for resuspension phenomena

J.G. Benito, R.O Uñac, A.M. Vidales, I. Ippolito



PII: S0021-8502(15)30051-3  
DOI: <http://dx.doi.org/10.1016/j.jaerosci.2016.05.008>  
Reference: AS5007

To appear in: *Journal of Aerosol Science*

Received date: 9 October 2015  
Revised date: 16 May 2016  
Accepted date: 22 May 2016

Cite this article as: J.G. Benito, R.O Uñac, A.M. Vidales and I. Ippolito Validation of the Monte Carlo model for resuspension phenomena, *Journal of Aerosol Science*, <http://dx.doi.org/10.1016/j.jaerosci.2016.05.008>

This is a PDF file of an unedited manuscript that has been accepted for publication. As a service to our customers we are providing this early version of the manuscript. The manuscript will undergo copyediting, typesetting, and a review of the resulting galley proof before it is published in its final citable form. Please note that during the production process errors may be discovered which could affect the content, and all legal disclaimers that apply to the journal pertain.

# Validation of the Monte Carlo model for resuspension phenomena

J.G. Benito<sup>a,\*</sup>, R. O Uñac<sup>a</sup>, A. M. Vidales<sup>a</sup>, I. Ippolito<sup>b</sup>

<sup>a</sup>*INFAP-UNSL-CONICET, Departamento de Física, Facultad de Ciencias Físico Matemáticas y Naturales, Universidad Nacional de San Luis, Ejército de los Andes 950, D5700HHW, San Luis, Argentina.*

<sup>b</sup>*Grupo de Medios Porosos, Facultad de Ingeniería, Universidad de Buenos Aires, Paseo Colón 850, 1063, Buenos Aires, Argentina.*

---

## Abstract

In this study we present a simulation model based on a Monte Carlo method to describe the resuspension of particles deposited on a flat surface due to air flow. Particles are attached to the surface through an adhesion force, and roughness effects between the particles and the surface are taken into account using a reduction factor. Two versions of the model are developed. In the first, the stochastic process used for particle resuspension is based on the evaluation of probabilities depending on the ratio between adhesion and aerodynamics forces and using a Metropolis function. In the second version, the resuspension probabilities are evaluated from a balance between the adhesion and the aerodynamics moments acting on each particle. A detailed comparison between the model results and different previous experiments is presented. Despite its simplicity, the model has a high capacity to describe the observed behavior of the resuspended particle fraction as a function of the air velocity. The good performance of the moment balance MC model version reveals the importance of considering the rolling mechanism in the resuspension phenomena modeling.

*Keywords:* Resuspension, Monte Carlo simulation, roughness, air velocity.

---

\*Corresponding author

*Email address:* jbenito@unsl.edu.ar (J.G. Benito)

## 1. Introduction

For many decades, a great deal of work has been performed on the problem of resuspension of deposited particles on a surface. Its presence in a wide set of industrial and environmental scenarios makes its study and description an important chapter in aerosol science (Bowling, 1988). This phenomenon is present in a wide range of fields, such as resuspension of airborne particles, reentrainment of sediments, human health, filtration systems and food industry. In particular, industrial applications requires perfectly clean surfaces for micro and nanoelectronic technology. Besides, the problem of resuspension causes serious difficulties in mining production. Indeed, mining operations are notable in the amount of particulates generated and the extent of polluted areas and toxicity, when compared with other sources of dust and aerosol emissions (Csavina et al., 2012; Stovern et al., 2014). Furthermore, resuspension phenomenon is essential in the study of radioactive particles released to the environment during nuclear accidents (Reeks et al., 1988; Stempniewicz et al., 2008; Zhang et al., 2013). Resuspension involves particles with different properties as well as a wide range of scales. One of the difficulties lies in the determination of the microscopic adhesion forces that result from the particles-surface interaction through a blend of mechanical stress, chemical bonds and physical attractions and where roughness plays an essential role. However, given the serious experimental difficulties in their determination, a theoretical approach is required to model particle-surface interactions. Other difficulties are the different flow conditions and the respective aerodynamic forces involved. Finally, many problems of particle resuspension involve the presence of multilayer deposits. The interaction between particles increases significantly the mechanism complexity with a potential mobilization by particle clustering (Ziskind, 2006; Hanus and Langrish, 2007; Boor et al., 2013; Henry and Minier, 2014b). All these open issues with the numerous applications make resuspension to remain the object of ongoing investigations. There are many comprehensive reviews concerning resuspension models in the

literature (Ziskind et al., 1995; Stempniewicz et al., 2008; Zhang, 2011; Henry and Minier, 2014a). In general, theoretical models developed to simulate the re-suspension properties can be divided according to the level of the description of particle motion on the surface. A first separation is made between empirical formulas and approaches that rely on a description of deposited particles through  
35 a set of particle equations. This second category is subdivided into: models that consider only particle equilibrium (force-balance and energy-accumulating models) and models which consider both the particle equilibrium and the particle dynamics on the surface as the relevant description (Henry and Minier, 2014a).  
40 Many models are based on a balance of forces that propose an instantaneous resuspension of particles when the removal forces are greater than the adhesion forces (Reeks et al., 1988). On the other hand, there are models allowing the movement of the particle on the surface before reentrainment and usually including a balance of moments acting on it (Guingo and Minier, 2008; Henry  
45 et al., 2012; Fu et al., 2013; Henry and Minier, 2014b; Tsai et al., 1991; Yiantsios and Karabelas, 1995; Ziskind et al., 1997; Wang, 1989, 1990). As one can expect, the choice of a force balance or a moment balance approach is related to the assumed motion of particles: rolling, described by moment balance, while sliding and lifting are properly described by a force balance (Ibrahim et al.,  
50 2008). In particular, Wen and Kasper (1989) developed a kinetic model based on the analogy between the process of resuspension and the kinetics of the first order reaction that describes the desorption of molecules from a heterogeneous surface. This kind of modelling opens the possibility to handle the resuspension phenomenon as a stochastic process.  
55 Recently, we have proposed a model based on a Monte Carlo (MC) simulation that takes advantage of the phenomenological Arrhenius expression for the determination of the resuspension rate (Benito et al., 2014). We have shown that the Metropolis function (Binder and Heermann, 1992), used as the transition probability between configuration states, is able to describe the principal  
60 characteristics of the resuspension flux for the case of a monolayer of particles deposited onto a flat surface and subjected to a turbulent flow. We considered

that the resuspension rate depends on the ratio between the adhesive force and the removal force acting on a particle.

We should mention that there are other MC models (Goldasteh et al., 2013; Fu et al., 2013) that use the balance between moments of adhesion and aerodynamic forces. In the MC simulations conducted by Fu et al. (2013) the angular velocity is calculated through Langevin equation and particle resuspension is assumed if the angular velocity is larger than a critical value, while Goldasteh et al. (2013) derived their MC simulations from the critical shear velocity for detachment of a rough particle.

The main difference between our MC model and the previous models is that we employ a MC method to deal with resuspension kinetics, i.e., the probability of a particle to be released from the surface is not necessarily equal to one if the adhesion force is less than the aerodynamic force and, moreover, the probability is not equal to zero if the aerodynamic force is less than the adhesion force. As we have shown in Benito et al. (2014), the model recovers the main aspects of the resuspension process and reproduces the experimental behavior for fractional mass resuspension vs. time. Given the potentiality of our model, our present challenge is to analyse the behavior of the MC simulations in case of particle detachment as a function of fluid velocity through the comparison with experimental resuspension results (Reeks and Hall, 2001; Ibrahim et al., 2003). In the following section, a brief description of the Monte Carlo model based on a force balance along with the rules of the stochastic process applied in the simulation routine are presented. In section 3, the results of comparing our MC model with different experimental data are shown. The performance of the force balance model gives rise to the need of a revision of the model. The new version is based on a moment balance, which is presented in section 4. Section 5 displays a complete comparison with experiments to test the efficiency of the new version of the model. A discussion of the obtained results and of the influence of the different model parameters is detailed in section 6 and, finally, the conclusions are presented in Section 7.

## 2. Resuspension Model based on a force balance

The model proposed for describing the resuspension of particles from a surface is based on a Monte Carlo method. Just as in a desorption process from a heterogeneous surface, we assume that the rate equation follows the Arrhenius law (Hughes, 1971). MC methods have been used for decades as versatile tools to describe molecular processes on surfaces (Binder and Heermann, 1992) and different extensions of these method have been proposed in order to take into account the kinetic mechanisms governing the resuspension of particles from a surface (Wen and Kasper, 1989; Benito et al., 2014).

A detailed description of the MC method based on the Metropolis function can be found in Benito et al. (2014). Briefly, we recall that assuming a  $N$ -particle system and considering only one possible type of transition, i.e., a deposited particle can resuspend to the gas stream, the probability  $P(t)dt$  of the system to perform a transition during the interval  $(t, t+dt)$  is given by a Poisson process (Sales et al., 1996)

$$P(t)dt = R \exp(-Rdt) \quad (1)$$

where  $R = \sum_{i=1}^N r_i$  is the total transition rate for the whole system of  $N$  particles and  $r_i$  is the resuspension transition rate for a single particle. The variable  $t$ , which is distributed following  $P(t)dt$ , is replaced by a random number  $\xi$ , uniformly distributed in the interval  $(0, 1)$  (Sales et al., 1996)

$$\Delta t = -\frac{\ln(\xi)}{R} \quad (2)$$

Equation 2 gives the actual time in which the system performs a transition. Thus, the total transition rate  $R$  (which is known in the simulation) along with Eq. 2, determine the relationship between the “virtual” MC time and the “actual” time of the system. Besides, when the transitions are carried out in equal time intervals,  $\Delta t$ , the actual elapsed time after  $N_s$  MC steps is simply  $t = N_s \Delta t$  (also referred as Kinetic Monte Carlo simulation).

We consider an idealized lattice structure of a monolayer deposit of  $N_0 = 10,000$  monosized particles with radius  $R_p$ . The distance between particles is

not relevant since they do not interact with each other. We take into account  
 120 the resuspension of the particles deposited on the flat surface as a single process  
 activated by the turbulent flow and, in our model, particles are not allowed  
 to move over the surface neither to be redeposited. Thus, there is a unique  
 resuspension rate  $r_i$  for a particle located at site  $i$ . We shall describe two  
 different versions based on the possibility of expressing the transition rate for  
 125 the Arrhenius type process in two different ways: one related to the balance of  
 forces acting on the particle and the other related to the balance of the moments  
 acting on it. Hereafter in this section we focus on the model version based on a  
 force balance, just as it was proposed in [Benito et al. \(2014\)](#).

Each particle belonging to the defined arrangement is considered to be at-  
 130 tached to the surface (substrate) by an adhesion force, and to be exposed to a  
 fluid flow that exerts aerodynamic forces and moments on it.

The adhesion force,  $F_a$ , is sampled from a lognormal distribution. This  
 choice is justified by the wide experimental evidence indicating this kind of  
 distribution for adhesive forces between particles and surfaces ([Bohme et al.,](#)  
 135 [1962](#); [Reeks et al., 1988](#); [Matsusaka et al., 1991](#); [Taheri and Bragg, 1992](#); [Reeks](#)  
[and Hall, 2001](#); [Salazar-Banda et al., 2007](#); [Zhang et al., 2013](#)). Its form is given  
 by

$$A(F_a) = \frac{1}{\sqrt{2\pi}F_a \ln \sigma_a} \exp \left( -\frac{1}{2} \left( \frac{\ln \frac{F_a}{\mu_a}}{\ln \sigma_a} \right)^2 \right) \quad (3)$$

where  $\mu_a$  and  $\sigma_a$  are the mean and the dispersion, respectively. In order to  
 account for the roughness effects, we consider that the mean adhesion force is a  
 140 certain percentage of the force value corresponding to a smooth contact ([Reeks](#)  
[and Hall, 2001](#); [Ibrahim et al., 2003, 2008](#)). In the case of a smooth contact,  
 the adhesion force can be estimated by the JKR theory ([Johnson et al., 1971](#)),  
 i.e., the adhesion force between a particle of radius  $R_p$  and the surface is given  
 by  $F_{JKR} = \frac{3}{2}\pi\gamma R_p$ , where  $\gamma$  is the adhesive surface energy of the particle and  
 145 substrate. Thus, the mean  $\mu_a$  can be written as

$$\mu_a = \frac{1}{f_r} F_{JKR} = \frac{1}{f_r} \frac{3}{2} \pi \gamma R_p \quad (4)$$

where  $f_r$  is a reduction factor that takes into account the contact geometry in a real surface which is characterized by a wide distribution of surface roughness. As already known, this will produce both a reduction and spread in the force of adhesion compared to that for a perfectly smooth contact (Reeks and Hall, 2001). Both,  $f_r$  and  $\sigma_a$  remain as model parameters. It is worth noting that the value of  $F_a$  assigned to each particle in the initial arrangement remains the same throughout the simulation. This is related to the fact that no rearrangements or particle motion are present on the surface.

As we mentioned above, the resuspension of a particle is assumed to be caused by a stochastic process resulting from the balance between adhesion forces and the forces exerted by air flow close to the wall due to irregular bursts or turbulent eddies. These aerodynamic forces are assumed to obey a Gaussian distribution as (Reeks and Hall, 2001).

$$B(F_h) = \frac{1}{\sqrt{2\pi}\sigma_h} \exp\left(-\frac{1}{2}\left(\frac{F_h - \mu_h}{\sigma_h}\right)^2\right) \quad (5)$$

where  $\mu_h$  and  $\sigma_h$  are the mean and the dispersion, respectively. For the mean value of the aerodynamic distribution we follow the assumptions made by most of the authors based on the mean drag on a sphere near a surface in simple shear flow (Stokes drag) in the predominantly viscous sub-layer (Friess and Yadigaroglu, 2001; Reeks and Hall, 2001; Ibrahim et al., 2003), i.e.,

$$\mu_h = c_h \rho_f v^{*2} R_p^2 \quad (6)$$

where  $\rho_f$  is the air density,  $v^*$  the friction velocity and  $c_h$  a constant (typically between 20 and 32). We also set  $\sigma_h = 0.33\mu_h$ , which reasonably represents the range of experimental values reported in the literature (Friess and Yadigaroglu, 2001). As it can be observed in Eq. 6, the mean aerodynamic force depends on the square of both, the particle radius and the friction velocity and does not take into account the surface geometry. An exponent of two lies within the



170 value range reported by other authors (Reeks and Hall, 2001; Ibrahim et al., 2003, 2008).

We consider that the transition rate  $r_i$  for the Arrhenius type process can be expressed as a first order kinetic process

$$r_i = k \exp \left[ - (F_a^i - F_h^i) / F_h^i \right] \quad (7)$$

where  $k$  is the frequency factor, which, as in other models, is related to the burst frequency. The different steps of the algorithm are as follows (Sales et al., 1996):

- (i) Let  $r \geq \max \{r_i\}$ ;  $R = N_a r$ ;  $t = t_0$ , where  $N_a$  is the number of particles still on the surface.
- (ii) Obtain a random number  $\xi$ ;  $\Delta t = -\ln(\xi)/R$ ;  $t = t + \Delta t$ .
- 180 (iii) Select randomly a deposited particle “ $i$ ”.
- (iv) Choose randomly an aerodynamic force from the distribution in Eq. 5
- (v) Evaluate  $r_i$  using Eq. 7.
- (vi) Obtain a new random number  $\xi$ ; if  $\xi < r_i/r$ , then accept the resuspension step at time  $t$ .
- 185 (vii) Repeat from step (ii) to (vi) until a certain period of time has elapsed or all the particles are resuspended.

It should be mentioned that  $\max \{r_i\}$  is calculated taking into account the extreme cases for both force distributions (adhesion and aerodynamic). The initial state corresponds to  $N_0$  particles deposited on the surface with an assigned 190 adhesion force to each of them. The algorithm described above allows recording the number of particles resuspended as a function of time. This information will enable us to compare the simulation results with different experimental sets of data and verify the capability of the MC model to describe resuspension phenomena.

### 195 3. Model results and experimental data

In order to estimate the predictive capability of the model we use two different sets of experimental data which are widely mentioned in the literature related to resuspension phenomena, namely, experimental results belonging to [Reeks and Hall \(2001\)](#) and to [Ibrahim et al. \(2003\)](#). In both cases, they considered the resuspension of a monolayer of particles caused by air flow in a turbulent channel flow from a defined surface.

[Reeks and Hall \(2001\)](#) reported measurements of resuspension for different particle-substrate systems. The experimental procedure consisted in measuring the particle fraction remaining on the surface after 1 s as a function of the friction velocity of the air flow. From all these results we focus on those experiments with  $10\mu\text{m}$ -diameter alumina particles deposited on a polished stainless-steel substrate.

On the other hand, experimental data reported by [Ibrahim et al. \(2003\)](#) is also chosen to compare with our model predictions. Here, authors presented a complete analysis of the particle detachment fraction as a function of the free-stream velocity of the air flow. While keeping the same glass substrate, they measure the particle detachment fraction for different materials (glass and stainless-steel) and different sizes ( $72$  and  $32\mu\text{m}$  diameter).

Summarizing, we selected the following sets of experimental data:

- 215 • Set 1:  $10\mu\text{m}$  alumina particles on stainless-steel substrate ([Reeks and Hall, 2001](#)).
- Set 2:  $70\mu\text{m}$  stainless-steel particles on glass substrate ([Ibrahim et al., 2003](#)).
- Set 3:  $72\mu\text{m}$  glass particles on glass substrate ([Ibrahim et al., 2003](#)).
- 220 • Set 4:  $32\mu\text{m}$  glass particles on glass substrate ([Ibrahim et al., 2003](#)).

The different materials properties are listed in Table 1.

Table 1: Materials properties used in experiments (Reeks and Hall, 2001; Ibrahim et al., 2003)

	Set 1	Set 2	Set 3 and 4
Particle diameter ( $\mu m$ )	10	70	72 and 32
Surface energy ( $Jm^2$ )	0.56	0.15	0.4
Substrate Young's modulus ( $GPa$ )	215	80.1	80.1
Particle Young's modulus ( $GPa$ )	2100	215	80.1
Substrate Poisson's ratio	0.29	0.27	0.27
Particle Poisson's ratio	0.3	0.28	0.27
Particle Density ( $Kgm^{-3}$ )	1600	8000	2420

Using the above described MC model, we first carry out simulations for the resuspension of alumina spheres ( $10\mu m$ -diameter) deposited on a stainless-steel surface (experimental set 1). We assign an adhesion force to each particle on the surface following a lognormal distribution (Eq. 3) with mean value given by Eq. 4, i.e.,  $\mu_a = \frac{1}{f_r} F_{JKR} = \frac{1.31 \times 10^{-5} N}{f_r}$ . Recall that both, the reduction factor,  $f_r$ , and the spread of the lognormal distribution,  $\sigma_a$ , remain as model parameters.

Each simulation starts at  $t = 0s$  with an initial friction velocity value  $u^*$  for the air flow. Following the algorithm steps mentioned in the previous section, we let the simulation perform the corresponding MC steps necessary to reach up  $t = 1s$  and compute the number of particles remaining on the surface. Then, we increase the friction velocity and repeat this process. The friction velocities are in compliance with the corresponding friction velocities reported by Reeks and Hall (2001), i.e., from  $0.25$  to  $3m/s$  approximately.

The comparison of the model with the experimental results (Set 1) is shown in Fig. 1. The values for the reduction factor used are  $f_r = 1053$  (filled circles) and  $f_r = 592$  (open circles). The solid line represents the experimental data, while the dashed line is the prediction achieved through the rock'n roll model proposed by Reeks et al. (2001). It is noteworthy that the values for the

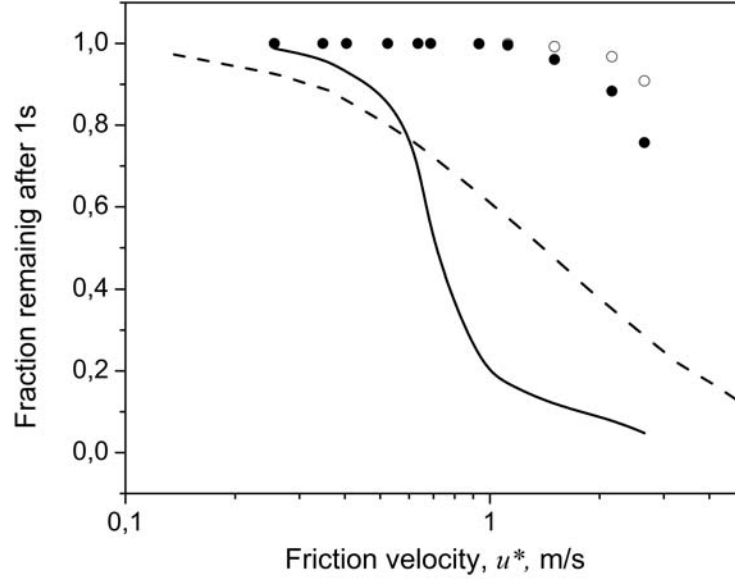

Figure 1: Comparison between the force balance MC model results and the experimental data set 1. Circles correspond to simulation results with  $f_r = 1053$  ( $\bullet$ ) and with  $f_r = 592$  ( $\circ$ ). Solid line represents experimental data set 1 and dashed line corresponds to the rock'n roll model.

reduction factor used in our simulations are the ones measured by [Reeks and Hall \(2001\)](#) and included in their rock'n roll model. Moreover, the value of the constant  $k$  in Eq. 7 is always chosen to be equal  $1s^{-1}$  and the value of the constant  $c_h$  is taken as 32 in the definition of  $\mu_h$  (see Eq. 6).

245 As it can be seen, the results obtained with our model are far from the experimental data, i.e., the remaining fractions obtained through simulations are systematically higher than the experimental ones, being practically over 0.8 for the entire range of friction velocities. Besides, even though the two simulated curves correspond to a single value of adhesion force dispersion ( $\sigma_a = 0.5$ ), the  
 250 variation of this parameter does not lead to significant changes in the results.

For the simulation of the experimental data set 2, extracted from [Ibrahim](#)

et al. (2003), we consider stainless steel particles ( $70\mu m$ -diameter) deposited on a glass surface. The assignment of the adhesion forces is performed as before, leading to  $\mu_a = \frac{1}{f_r} F_{JKR} = \frac{2.47x10^{-5} N}{f_r}$ . In order to reproduce the air flow conditions reported by the authors we increase the free-stream velocity linearly with time up to  $\sim 11m/s$  in 60s. In order to link the free-stream velocity  $U$  and the friction velocity  $u^*$ , we assume the linear relationship measured by Ibrahim et al. (2003), i.e.,  $u^* = 0.0375U + 0.0387$ . Following the MC algorithm we record the amount of particles detached from the surface as a function of the free-stream velocity.

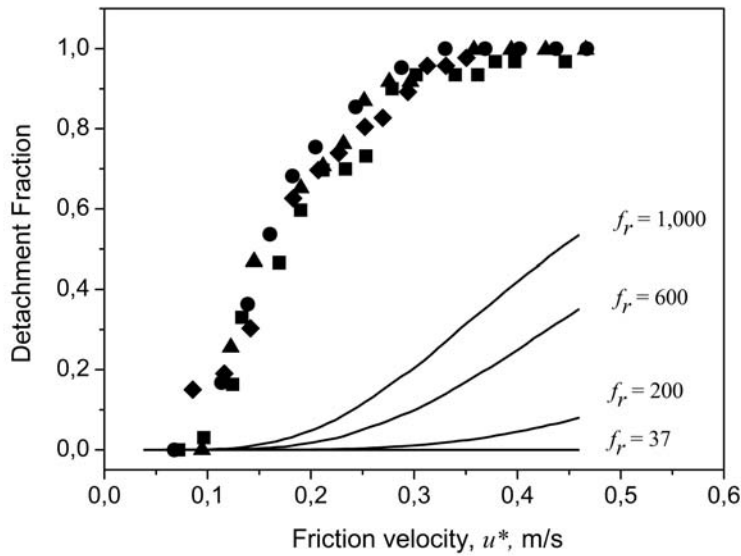

Figure 2: Comparison between the force balance MC model results and the experimental data set 2. Solid lines correspond to simulation results with different  $f_r$  values and filled symbols represents different repetition of the experiment.

Figure 2 shows the simulation results obtained in this case along with experimental data set 2. It is important to note that, in order to avoid confusion, we plot the detachment fraction as a function of the friction velocity (which is

linearly related to the free-stream velocity  $U$ ). Curves (solid lines) correspond  
265 to different values for the reduction factor  $f_r$  (ranging from 37 to 1000) and  
symbols are the different repetitions of the original experiment. The value of  
the constant  $c_h$  (see Eq. 6) is taken equal to 32 in all the simulations.

Again, the results do not resemble the experiments. Despite the  $f_r$  value is  
gradually increased, implying smaller values of adhesion forces, it is not enough  
270 to reproduce the detachment mechanism. Note that a value of  $f_r$  equal to  
1000 implies 0.1% of the adhesion force for a smooth contact,  $F_{JKR}$ , which is  
already a very small value given that roughness reduces the adhesion force to  
approximately 1% of the smooth JKR force (Ibrahim et al., 2003; Zhang et al.,  
2013; Zhang, 2011).

275 Moreover, to get a better approach to the experimental results, one could  
increase the aerodynamic force through the parameter  $c_h$  in Eq. 6 instead of  
decreasing the adhesion force. Nevertheless, the value  $c_h = 32$  is already one  
of the highest values found in the literature for tangential drag forces (Reeks  
and Hall, 2001). Summarizing, the possibilities for the values of  $c_h$  and  $f_r$  to  
280 improve the simulation results do not correspond to actual physical situations  
in the experiments.

Since we find the same poor simulation performance for experimental data  
sets 3 and 4, the corresponding comparisons are not shown here.

The present results lead us to conclude that our MC model based on a force  
285 balance is not appropriate to explain the experimental resuspension evidence.  
This is in agreement with the statements of other authors (Ibrahim et al., 2003,  
2008; Guingo and Minier, 2008; Henry et al., 2012; Henry and Minier, 2014b;  
Fu et al., 2013) who claim to the conclusion that force-balance models system-  
atically underestimate the resuspension rate observed in experiments. This is  
290 due to the fact that this kind of balance accounts for a direct pull off of par-  
ticles which has been set aside as the dominant mechanism through numerous  
experimental and numerical evidence.

One way to improve our model is to consider that the aerodynamic force,  
though small, may take-off a particle from the surface thanks to the moment act-

ing on it and thus, depending on the lever arm, the aerodynamic effect could be  
 significant. There are numerous resuspension models and experimental evidence  
 that set out particle rolling as the main mechanism responsible for resuspension  
 (Goldasteh et al., 2013; Fu et al., 2013; Ibrahim et al., 2003). Therefore, in the  
 next section we will focus on a new version of the MC model based on a moment  
 balance that would account for the mentioned rolling effects.

#### 4. Resuspension model based on a moment balance

The MC model presented here is essentially an extension of the one used  
 above. Therefore, all the assumptions regarding MC method based on the  
 Metropolis function remain without modification, except for the definition of  
 the transition rate  $r_i$ , which is now expressed through the balance between mo-  
 ments of adhesion and aerodynamic forces. In our moment balanced MC ver-  
 sion model we simplify particles motion and we consider that rolling is the only  
 movement responsible for the resuspension. This is based on the conclusions  
 of Ibrahim et al. (2003) who experimentally observed that particle detachment  
 does not occur by direct pull-off, but rather through motion along the surface  
 (rolling and/or sliding). Moreover, with their model results they proved that  
 “rolling” is the dominant detachment mode and detachment by sliding requires  
 a much higher flow velocity or very small static friction coefficients (which were  
 not realistic values).

A scheme of all the forces acting on each particle of radius  $R_p$  is shown in  
 Fig. 3. The diagram includes four forces: the gravitational force,  $F_g$  ( $mg$ ), the  
 adhesion force,  $F_a$ , the lift force,  $F_L$ , in the upward vertical direction, and the  
 drag force,  $F_d$ , in the forward horizontal direction. Both  $F_L$  and  $F_d$  express  
 the aerodynamic effects. Sketches like the one shown in Fig. 3 have been  
 extensively used to illustrate the force scheme involved in the analysis of a  
 particle detachment (Ibrahim et al., 2003; Zhang, 2011; Zhang et al., 2013; Tsai  
 et al., 1991; Cabrejos and Klinzing, 1992).

The contact radius  $a_0$  is evaluated assuming the JKR theory for a smooth

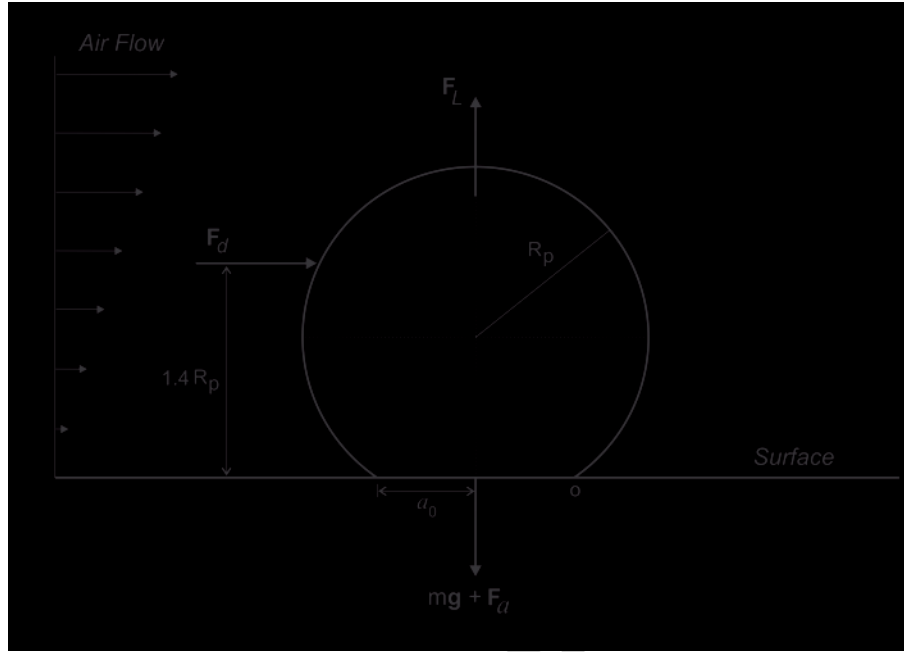

Figure 3: Particle Force diagram.

surface

$$a_0 = \left( \frac{6\pi\gamma R_p^2}{4K} \right)^{1/3} \quad (8)$$

325 where  $\gamma$  is the surface energy of adhesion and  $K$  the composite Young's modulus

$$K = \frac{4}{3} \left[ \frac{(1 - \nu_1^2)}{E_1} + \frac{(1 - \nu_2^2)}{E_2} \right]^{-1} \quad (9)$$

with  $E_1$  and  $E_2$  the values of Young's modulus and  $\nu_1$  and  $\nu_2$  the values of Poisson's ratios for the particle and the surface, respectively. It is important to note that the real contact radius is smaller than the one corresponding to the perfectly smooth contact case. Nevertheless, the reduction of the contact area  
 330  $a_0$  due to roughness is not taken into account herein and we just approximate this area (which is going to be relevant in the moment balance equation) with the one corresponding to the smooth case (as well as in [Ibrahim et al. \(2003\)](#) and [Ibrahim et al. \(2008\)](#)).



The moment balance around the point O, located at a distance  $a_0$  from the  
 335 particle axis in the downstream direction, is expressed by (Ibrahim et al., 2003)

$$(1.4R_p)F_d + a_0F_L = a_0(F_a + mg) \quad (10)$$

The moment of the tangential drag force is due to the non-uniformity of the  
 air flow. The expression used in Eq. 10 has been analytically obtained by O'Neill  
 (1968) where the factor 1.4 accounts for the presence of the surface. The analysis  
 of order of magnitude for the other forces involved, shows that the aerodynamic  
 340 lift and gravitational moments are negligible compared to the drag and adhesion  
 moments. Therefore, for the analysis considered here, resuspension is dictated  
 by a balance between the aerodynamic drag and adhesion force moments.

Thus, similarly to the transition rate proposed before (section 2), we now  
 express  $r_i$  as

$$r_i = k \exp \left[ - (M_a^i - M_d^i) / M_d^i \right] \quad (11)$$

345 where  $M_a = a_0F_a$  and  $M_d = 1.4R_pF_d$ .

The intensity of adhesion forces  $F_a$  follows the lognormal distribution stated  
 above (Eqs. 3 and 4) and the drag forces  $F_d$  are taken from a gaussian dis-  
 tribution analogous to the one used previously (Eqs. 5 and 6), but using the  
 subscript “d” instead of “h” to distinguish between the drag force in the tan-  
 350 gential direction and a general aerodynamic force.

The algorithm steps are the same as listed before. Once again, the results  
 obtained through simulations are compared in the next section with the different  
 sets of experimental data and will enable us to verify the potentiality of this  
 new proposed version.

## 355 5. Performance of the moment balance model

In order to compare simulation results with the experimental data set 1  
 (Reeks and Hall, 2001) we proceed as in section 3. The alumina spheres ( $10\mu m$ -  
 diameter) are deposited on a stainless-steel surface with a contact radius  $a_0 =$

0.140 $\mu$ m. The mean for the adhesion force distribution is given by  $\mu_a =$   
 360  $\frac{1}{f_r} F_{JKR} = \frac{1.31 \times 10^{-5} N}{f_r}$ , and the air friction velocity is varied from 0.25 to approximately 3m/s. As before, constants  $k$  and  $c_d$  are taken equal to  $1s^{-1}$  and 32, respectively.

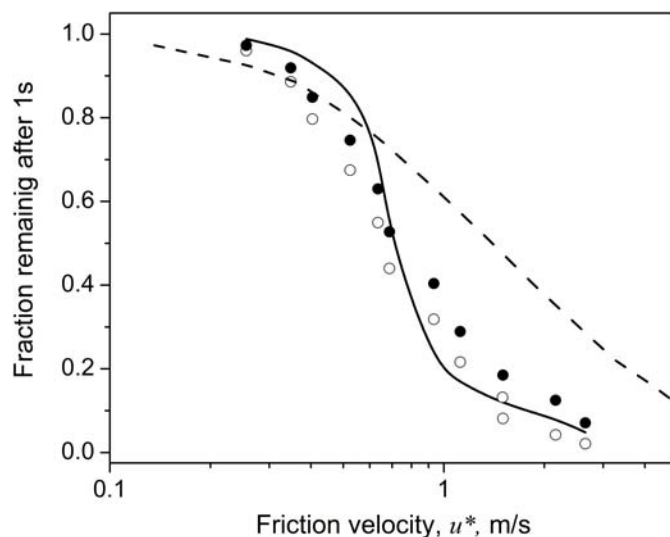

Figure 4: Comparison between the moment balance model results and experimental data set 1. Circles correspond to simulation results with  $f_r = 456$  ( $\bullet$ ) and with  $f_r = 592$  ( $\circ$ ). Solid line represents experimental data set 1 and dashed line corresponds to the rock'n roll model.

Figure 4 shows the simulation results obtained in this case along with experimental data set 1. Symbols correspond to simulations with  $f_r = 456$  (filled circles) and  $f_r = 592$  (open circles). The solid line represents the experimental data, while the dashed line is the prediction of the rock'n roll model. It is worth noting that the value of the reduction factor 592 corresponds to one of those reported by Reeks and Hall (2001) while the simulation results with reduction factor of 456 is shown in order to check the effect of varying this model  
 365 parameter.  
 370

We now observe that model results for the particle remaining fraction vs.

friction velocity are in good agreement with the experimental data. Even more, our model improves the prediction compared with the rock'n roll model.

For the comparisons with data sets 2, 3 and 4 (Ibrahim et al., 2003), the simulation procedure is the same as explained in section 3. We record the number of particles detached from the glass surface as a function of the free-stream velocity. For  $70\mu\text{m}$ -diameter stainless steel particles and  $72\mu\text{m}$ -diameter glass particles (experimental set 2 and 3), the free-stream velocity increase linearly with time up to  $\sim 11\text{m/s}$  in 60s. On the other hand, for the experimental set 4, i.e.,  $32\mu\text{m}$ -diameter glass particles, the velocity increase linearly from 0 to  $\sim 23\text{m/s}$  in 150s. Again, we link the free-stream velocity  $U$  and the friction velocity  $u^*$  through the linear relationship  $u^* = 0.0375U + 0.0387$ . Table 2 shows the values of the different constants used in all the simulations.

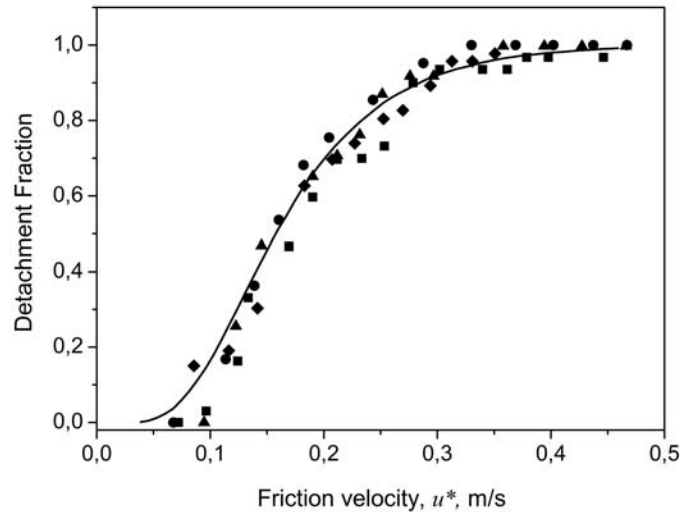

Figure 5: Comparison between the moment balance MC model results and the experimental data set 2. Solid line correspond to the simulation results with  $f_r = 100$  and filled symbols represents different repetition of the experiment.

Figure 5 shows the corresponding comparison between data set 2 and simulations. The solid line corresponds to simulations with a reduction factor  $f_r = 100$

and symbols are the different repetitions of the original experiment. As it can be seen, the moment balance model results are in good agreement with the experimental behavior.

Table 2: Values for different constants used in the simulations.

	Set 1	Set 2	Set 3	Set 4
Composite Young's modulus ( $Pa$ )	1.92E11	8.41E10	5.76E10	5.76E10
Contact radius $a_0$ ( $\mu m$ )	0.140	0.435	0.685	0.406
$F_{JKR}$ ( $N$ )	1.32E-5	2.47E-5	6.59E-5	3.02E-5
$f_r$	592 and 456	100	200	43

Finally, the comparison between simulations and experimental sets 3 and 4 are shown in Fig. 6. Open and solid symbols represent the experimental results for glass particles with  $72\mu m$  and  $32\mu m$  diameter, respectively. The solid line corresponds to simulations with a reduction factor  $f_r = 200$  in Fig. 6(a) and with  $f_r = 43$  in Fig. 6(b). Once again, the comparison shows the good performance of our MC moment balance model.

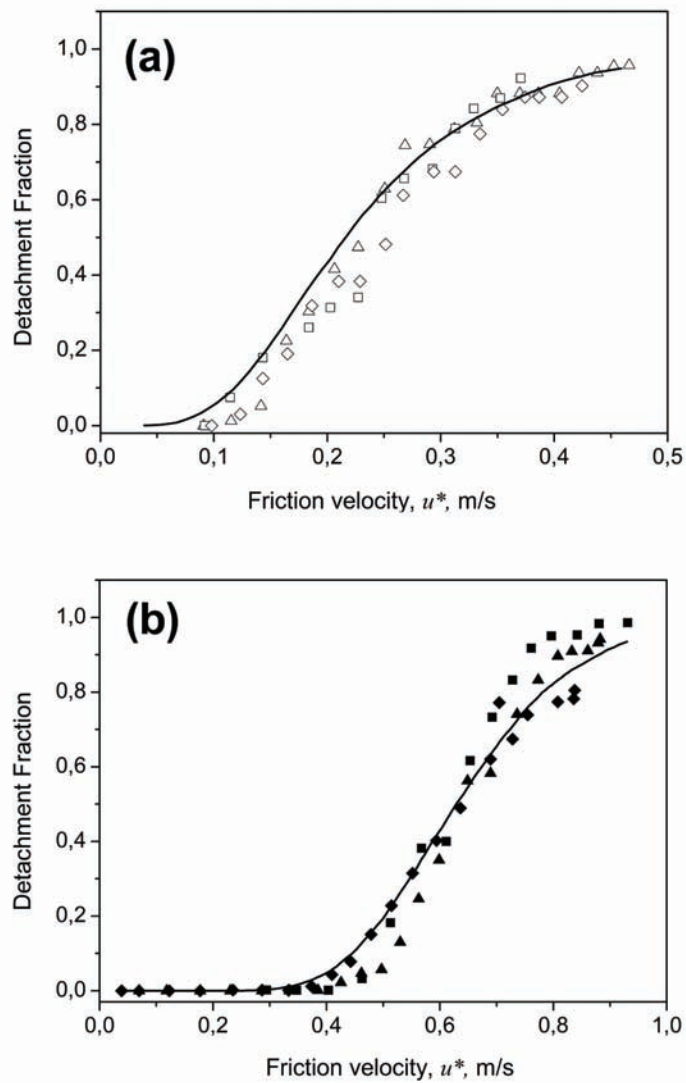

Figure 6: Comparison between the moment balance MC model results and experimental data set 3 and 4. (a) Solid line correspond to simulation results  $f_r = 200$  and open symbols represents different repetition of the experiment. (b) Solid line correspond to simulation results  $f_r = 43$  and filled symbols represents different repetition of the experiment.

395 **6. Discussion**

In this paper we show that a model that takes into account the moment balance is more successful in its predictive ability compared with a model considering the force balance.

Indeed, the appearance of the lever arm of  $a_0$  in the expression of  $r_i$  (Eq.11) 400 allows us to obtain adequate resuspension probabilities, which indicates that the incorporation of the rolling mechanism was crucial for a proper phenomenon description.

Clearly, one could tune the probability in Eq. 7, related to force balance, by an appropriate force distribution in order to mimic the effect of  $a_0$ . However, this 405 “tuning” could not be supported by experimental evidence. This behavior led us to think that the only possibility was to redefine the resuspension probabilities in order to take into account the rolling mechanism (based on the moment balance equation).

Regarding the predictive ability of our moment balance model, it can be seen 410 that for the experimental set 1 (Reek’s experiments), the model underestimates the remaining fraction for low friction velocities  $u^*$ , while for the rest of velocities the performance is quite good (see Fig.4). This could be due to our lack of information about the initial conditions under which the steady flow develops in the wind channel and on the way the velocity variation is performed over 415 time. Besides, considering the role of the reduction factor  $f_r$ , it can be seen that a slight variation of this parameter better describes the low friction velocity behavior, nevertheless the simulation results depart for the rest of the velocity range. Another possible explanation would be that the underestimation could be due to the fixed relationship used in our model between the mean of the 420 aerodynamic force  $\mu_h$  (proportional to the  $u^*$ ) and the dispersion  $\sigma_h$  which overestimates the presence of bursts in the low velocity regime. In this way, one could expect for low airflow velocities (with laminar behavior), burst formation, underestimates the remaining fractions.

On the other hand, for all the sets belonging to [Ibrahim et al. \(2003\)](#), the

425 description of the simulation model is really good in most of the range of the  
free-stream velocities  $U$  (see Fig. 5 and 6). The simulation curves lie in the  
range of the dispersion for the experimental data. We would say that the values  
of the reduction factor  $f_r$  selected for each of the simulations (whose actual  
value we did not know through experiments) are close to the reported adhesion  
430 force reduction due to roughness (Reeks and Hall, 2001; Ibrahim et al., 2003,  
2008).

Concerning the values used for  $f_r$ , stainless steel spheres have half the value  
than glass spheres. This is reasonable considering the type of surfaces involved,  
i.e., it is expected that the metal surface would be smoother than the glass one.  
435 On the other hand, the comparison of the reduction factors for the two differ-  
ent size glass spheres would indicate that the adhesion forces for the smaller  
particles result to double the ones for bigger particles. This can be simply de-  
duced from the geometrical considerations for the reduction factor employed by  
Derjaguin et al. (1975); Greenwood and Williamson (1966); Rabinovich et al.  
440 (2000a,b).

On the other hand, it is important to comment that we have just varied the  
adhesive forces through the reduction factor. Despite this, the lever arm  $a_0$  in  
Eq. 10 could be varied to obtain similar results. Both parameters,  $f_r$  and  $a_0$ ,  
allow taking into account roughness effects and, in fact, are connected to each  
445 other.

Comparing our model with the performance of other MC models (Goldasteh  
et al., 2013), our results really demonstrate in a better way the capability of the  
MC method for the description of the resuspension phenomena studied here.  
In particular, it is worthy to mention that unlike other models, our comparison  
450 with the data belonging to Ibrahim et al. (2003) is performed on a linear scale  
in the horizontal axes (and not a logarithmic scale), with satisfactory results.

It is also important to remark that in our MC model we assume that the  
distance between particles is not relevant. In the first version of the model,  
i.e., the version based on a force balance, this assumption is made because the  
455 mechanism underlying in the process is the direct pull-off. On the other hand,

in the MC version that allows particles to roll, once the rupture of the balance between aerodynamic and adhesion forces occurs, we assume that the particle resuspends and we do not analyze the subsequent motion. Thus, the distance is also negligible in the second version.

460 At this stage of the discussion, it is relevant to comment why the force-balance model was appropriate to describe the experimental data presented in Benito et al. (2014) and belonging to Giess et al. (1997). In that paper we fitted a small set of results for the fractional mass as a function of time for porous silica particles, deposited on grass. The simulation results were less sensitive  
465 to the exponent value used in the expression for  $r_i$ , since they were obtained from an integral mass resuspension along time. Besides, and more important, we did not know nothing about the adhesion force involved in the problem and plausible assumptions had to be made.

Finally, it is worth mentioning here that all the results used to compare the  
470 prediction of our MC model were performed with a controlled relative humidity. In particular, Ibrahim et al. (2003) conducted the experiments with a relative humidity of  $25 \pm 3\%$ , and this indicates us that the cohesive forces related to capillarity are negligible. The effect of a capillary force in resuspension phenomena have been reported by other authors (Ibrahim et al., 2004; Matsusaka and  
475 Masuda, 1996; Gradoń, 2007; Alloul et al., 2000) resulting in the need of greater aerodynamic forces for particle resuspension and clusters formation. Future efforts would be devoted to incorporate humidity effects in our MC model as well as particle-particle interaction.

## 7. Conclusion

480 In this paper we analyse the potentiality of our MC model (Benito et al., 2014). We verify that this simple model can reproduce a wide range of experimental data.

Here we find that the first version of the MC model presented, i.e., the one based on a force-balance, is not suitable for the representation of the resuspen-



485 sion fractions as a function of the air velocity. However, the present version covers all the behavioural features of the resuspension rate as a function of time (as it is proved in [Benito et al. \(2014\)](#)).

Based on a moment balance, the model results reproduce quite well all the experimental sets examined. Thereby, the rolling mechanism turned out to  
490 be crucial to explain the detachment process of the particles from the surface. This is in agreement with the conclusions reached by [Reeks and Hall \(2001\)](#) and [Ibrahim et al. \(2003\)](#) who established that although particles can slide or directly be pulled-off, these mechanisms are not significant compared to the rolling one.

495 Our Monte Carlo model incorporates the stochastic nature of adhesion and the interaction forces that appear in the resuspension phenomenon, complementing the assumptions and results of previous models [Reeks and Hall \(2001\)](#); [Zhang et al. \(2013\)](#); [Zhang \(2011\)](#) and [Guingo and Minier \(2008\)](#). The model takes into account the surface roughness through the correction factor  $f_r$ . The  
500 wide range of values for this parameter obtained from the comparison with the experimental data lead us to think that the relationship between this parameter and the surface roughness should be deeply explored in future works. Besides, we know that the force balance model is based on a simple concept where the resuspension of particles is assumed to take place instantaneously when the  
505 aerodynamic forces exceed the surface adhesive force. On the other hand, we also know that the rolling concept is the main one explaining most of the behavior found in resuspension, but it is not the only one. For that reason, we understand that a MC model combining several mechanisms for resuspension would be welcome and, in this sense, we are making progress in it.

510 Finally, our MC model allows to easily change the force distributions involved in the problem and to use parameters that could be clearly provided by the experimental set-up. Furthermore, the model could be used to estimate adhesion forces when there is no way to measure them. On the other hand, it also has the advantage of being able to reproduce different wind conditions,  
515 allowing to change the velocity variation versus time in a simple way. Besides,

the simulation time elapsed in each run is quite short and we do not have to solve any integral equation.

## References

- Alloul, L., Witschger, O., Dur, D. L., Renoux, A., Monnatte, J., 2000. Re-  
520 entrainment of particles from powder structures: experimental investigations.  
Journal of Aerosol Science 31, 835–836.
- Benito, J., Aracena, K. V., Uñac, R., Vidales, A., Ippolito, I., 2014. Monte  
carlo modelling of particle resuspension on a flat surface. Journal of Aerosol  
Science 79, 126–139.
- 525 Binder, K., Heermann, D., 1992. Monte carlo simulation in statistical physics:  
An introduction. 2nd. ed. Berlin: Springer Verlag.
- Bohme, G., Krupp, H., Rabenhorst, H., Sandstede, G., 1962. Adhesion measure-  
ments involving small particles. Transactions of the Institution of Chemical  
Engineers 40, 252–259.
- 530 Boor, B., Siegel, J., Novoselac, A., 2013. Monolayer and multilayer particle  
deposits on hard surfaces: Literature review and implications for particle  
resuspension in the indoor environment. Aerosol Science and Technology 47,  
831–847.
- Bowling, R., 1988. A theoretical review of particle adhesion. particles on surfaces  
535 i: Detection, adhesion and removal. New York: Plenum Press, 129–142.
- Cabrejos, F. J., Klinzing, G. E., 1992. Incipient motion of solid particles in  
horizontal pneumatic conveying. Powder Technology 72, 51–61.
- Csavina, J., Field, J., M.P. Taylor, M., Gao, S., Landzuri, A., Betterton, E., Sez,  
A., 2012. A review on the importance of metals and metalloids in atmospheric  
540 dust and aerosol from mining operations. Science of the Total Environment  
433, 58–73.

- Derjaguin, B. V., Muller, V. M., Toporov, Y. P., 1975. Effect of contact deformations on the adhesion of particles. *Journal of Colloid and Interface Science* 53, 314–326.
- 545 Friess, H., Yadigaroglu, G., 2001. A generic model for the resuspension of multilayer aerosol deposits by turbulent flow. *Nuclear Science and Engineering* 138, 161–176.
- Fu, S., Chao, C., SO, R., Leung, W., 2013. Particle resuspension in a wall-bounded turbulent flow. *Journal of Fluids Engineering* 135, 041301.
- 550 Giess, P., Goddard, A., Shaw, G., 1997. Factors affecting particle resuspension from grass swards. *Journal of Aerosol Science* 28, 1331–1349.
- Goldasteh, I., Goodarz, A., Ferro, A., 2013. Monte carlo simulation of micron size spherical particle removal and resuspension from substrate under fluid flows. *Journal of Aerosol Science* 66, 62–71.
- 555 Gradoń, L., 2007. Re-entrainment of particles from powder structures: experimental investigations. *Advanced Powder Technology* 18, 427–439.
- Greenwood, J. A., Williamson, J. B. P., 1966. Contact of nominally flat surfaces. *Proceedings of the Royal Society A* 295, 300–319.
- Guingo, M., Minier, J.-P., 2008. A new model for the simulation of particle resuspension by turbulent flows based on a stochastic description of wall roughness and adhesion forces. *Journal of Aerosol Science* 39, 957–973.
- 560 Hanus, M., Langrish, T., 2007. Resuspension of wall deposits in spray dryers. *Journal of Zhejiang University SCIENCE A* 8(11), 1762–1774.
- Henry, C., Minier, J.-P., 2014a. Progress in particle resuspension from rough surfaces by turbulent flows. *Progress in Energy and Combustion Science* 45, 1–53.

- Henry, C., Minier, J.-P., 2014b. A stochastic approach for the simulation of particle resuspension from rough substrates: Model and numerical implementation. *Journal of Aerosol Science* 77, 168–192.
- 570 Henry, C., Minier, J.-P., Lefreuve, G., 2012. Numerical study on the adhesion and reentrainment of nondeformable particles on surfaces: The role of surface roughness and electrostatic forces. *Langmuir* 28, 438–452.
- Hughes, E. M., 1971. *The chemical statics and kinetics of solutions*. London: Academic Press.
- 575 Ibrahim, A., Dunn, P., Brach, R., 2003. Microparticle detachment from surfaces exposed to turbulent air flow: controlled experiments and modeling. *Journal of Aerosol Science* 29, 765–782.
- Ibrahim, A., Dunn, P., Brach, R., 2004. Microparticle detachment from surfaces exposed to turbulent air flow: Effects of flow and particle deposition characteristics. *Journal of Aerosol Science* 35, 805–821.
- 580 Ibrahim, A., Dunn, P., Qazi, M., 2008. Experiments and validation of a model for microparticle detachment from a surface by turbulent air flow. *Journal of Aerosol Science* 29, 645–656.
- Johnson, K., Kendall, K., Roberts, A., 1971. Surface energy and the contact of elastic solids. *Proceedings of the Royal Society of London. Series A, Mathematical and Physical* 324, 301–313.
- 585 Matsusaka, S., Aoyagi, T., Masuda, H., 1991. Unsteady particle-reentrainment model based on the internal adhesive strength distribution of a fine powder layer. *Kagaku Kogaku Ronbunshu* 17, 1194–1200.
- 590 Matsusaka, S., Masuda, H., 1996. Particle reentrainment from a fine powder layer in a turbulent air flow. *Aerosol Science and Technology* 24, 69–84.
- O'Neill, M., 1968. A sphere in contact with a plane wall in a slow linear shear flow. *Chemical Engineering Science* 23, 1293–1298.

- 595 Rabinovich, Y. I., Adler, J. J., Ata, A., Singh, R. K., Moudgil, B. M., 2000a. Adhesion between nanoscale rough surfaces: I. role of asperity geometry. *Journal of Colloid and Interface Science* 232, 10–16.
- Rabinovich, Y. I., Adler, J. J., Ata, A., Singh, R. K., Moudgil, B. M., 2000b. Adhesion between nanoscale rough surfaces: II. measurement and comparison with theory. *Journal of Colloid and Interface Science* 232, 17–24.
- 600 Reeks, M., Hall, D., 2001. Kinetic models for particle resuspension in turbulent flows: theory and measurement. *Journal of Aerosol Science* 32, 1–32.
- Reeks, M., Reed, J., Hall, D., 1988. On the resuspension of small particles by a turbulent flow. *Journal of Physics D: Applied Physics* 21, 574–598.
- Salazar-Banda, G., Felicetti, M., Goncalves, J., Coury, J., Aguiar, M., 2007. 605 Determination of the adhesion force between particles and a flat surface, using the centrifuge technique. *Powder Technology* 173, 107–117.
- Sales, J., Uñac, R., Gargiulo, M., Bustos, V., Zgrablich, G., 1996. Monte carlo simulation of temperature programmed desorption spectra: A guide through the forest for monomolecular adsorption on a square lattice. *Langmuir* 12, 610 95–100.
- Stempniewicz, M., Komen, E., de With, A., 2008. Model of particle resuspension in turbulent flows. *Nuclear Engineering and Design* 238, 2943–2959.
- Stovern, M., Felix, O., Csavina, J., Rine, K., Russell, M. R., Jones, R., King, M., Betterton, E., Sez, A., 2014. Simulation of windblown dust transport from 615 a mine tailings impoundment using a computational fluid dynamics model. Aeolian Research.
- Taheri, M., Bragg, G., 1992. A study of particle resuspension in a turbulent flow using a preston tube. *Aerosol Science and Technology* 16, 15–20.
- Tsai, C.-J., Pui, D. Y. H., Liu, B. Y. H., 1991. Particle detachment from disk 620 surfaces of computer disk drives. *Journal of Aerosol Science* 22, 737–746.

- Wang, H., 1989. Theoretical comparison on mechanisms to overcome particle surface adhesion. *Journal of Aerosol Science* 20, 919–922.
- Wang, H., 1990. Effects of inceptive motion on particle detachment from surfaces. *Aerosol Science and Technology* 13, 386–393.
- 625 Wen, H., Kasper, G., 1989. On the kinetics of particle reentrainment from surfaces. *Journal of Aerosol Science* 20, 483–498.
- Yiantsios, S. G., Karabelas, A. J., 1995. Detachment of spherical microparticles adhering on flat surfaces by hydrodynamic forces. *Journal of Colloid and Interface Science* 176, 74–85.
- 630 Zhang, F., 2011. The modelling of particle resuspension in a turbulent boundary layer. Ph.D. thesis, School of Mechanical and System Engineering Newcastle University, United Kingdom, and Laboratoire de Mcanique des Fluides et d'Acoustique Ecole Centrale de Lyon, France, and references there in.
- Zhang, F., Reeks, M., Kissane, M., 2013. Particle resuspension in turbulent 635 boundary layers and the influence of non-gaussian removal forces. *Journal of Aerosol Science* 58, 103–128.
- Ziskind, G., 2006. Particle resuspension from surfaces: revisited and re-evaluated. *Reviews in Chemical Engineering* 22, 1–123.
- Ziskind, G., Fichman, M., Gutfinger, C., 1995. Resuspension of particles from 640 surfaces to turbulent flows - review and analysis. *Journal of Aerosol Science* 26, 613–644.
- Ziskind, G., Fichman, M., Gutfinger, C., 1997. Adhesion moment model for estimating particle detachment from a surface. *Journal of Aerosol Science* 28, 623–634.