



Assessing the effects of demersal fishing and conservation strategies of marine mammals over a Patagonian food web



Matías Ocampo Reinaldo^{a,b,*}, Andrés C. Milessi^{c,d}, María Alejandra Romero^{a,b}, Enrique Crespo^{b,e}, Matthias Wolff^f, Raúl A. González^{a,b}

^a Escuela Superior de Ciencias Marinas (ESCiMar)/Instituto de Biología Marina y Pesquera "Almirante Storni" (IBMPAS), Universidad Nacional del Comahue, Güemes 1030, R8520CXV San Antonio Oeste, Argentina

^b Consejo Nacional de Investigaciones Científicas y Tecnológicas (CONICET), Rivadavia 1917, <postalC>1033</postalC> Ciudad Autónoma de Buenos Aires, Argentina

^c Comisión de Investigaciones Científicas de la Provincia de Buenos Aires (CIC), Buenos Aires, Argentina

^d Instituto Nacional de Investigación y Desarrollo Pesquero, Paseo Victoria Ocampo 1, B7602HSA Mar del Plata, Argentina

^e Centro Nacional Patagónico (CENPAT/CONICET), Bvd. Brown 2915, 9120 Puerto Madryn, Argentina

^f Leibniz Centre for Tropical Marine Ecology, Fahrenheitstrasse 6, 28359 Bremen, Germany

ARTICLE INFO

Article history:

Received 1 April 2015

Received in revised form 5 October 2015

Accepted 16 October 2015

Available online 29 November 2015

Keywords:

Demersal fishing

Food web

South American sea lion

Argentine hake

Ecopath with Ecosim

Patagonia

ABSTRACT

The San Matías Gulf (SMG) is a semi-enclosed ecosystem where the Argentine hake *Merluccius hubbsi* (AH) has been the main fishery resource since 1971. During the 20th century the South American sea lion *Otaria flavescens* (SASL) population was severely reduced in this ecosystem due to an intense hunting, but in the 1970's conservation was promoted and hunting was banned. As a consequence SASL have been slowly recovering, until the 1990's when rapidly rebuilt their populations. Recent studies indicate that they feed mostly over commercially profitable medium-sized AH. Also, medium-sized and large hake are well-known cannibals that feed heavily over smaller AH. Fishing trawlers affect juvenile and medium-sized AH and artisanal long-liners capture exclusively large AH. The objective of this study was to evaluate the effect of a growing SASL population over the AH in the SMG, considering the changes in the fishing activity as well as the size-structured cannibalism within the AH population. The evaluations were based on time series of hake and SASL biomass using the "Ecopath with Ecosim" dynamic modelling approach. The analyses show that over 4 decades the increase in Sea Lions biomass has not generated a significant increase in the predation mortality over AH. On the other hand, an increase and subsequent variations in the fishing mortality seems to be related with long-term variations in large AH abundance, and a decrease in medium-sized AH abundance, constraining the cannibalism mortality. This led to a positive effect over juvenile AH abundance due to a released cannibalism pressure, even considering that the less abundant larger AH are also the main spawners of the population. In this scenario, where it seems that trawlers and long-liners have replaced several predators over the SMG food web, SASL population is still growing but they may not reach the pristine abundance levels of the time before hunting.

© 2015 Elsevier B.V. All rights reserved.

1. Introduction

Marine ecosystems are currently under change due to different reasons: intensive fishing, climate change and pollution, among others. Fishing is a widely known activity that usually targets a few components of the ecosystems; other components are often

discarded (Kelleher, 2005; Rochet and Trenkel, 2005) or affected indirectly through food web effects (Crespo et al., 1997). For instance, in some heavily fished ecosystems top predator biomass has declined substantially, inducing major changes in ecosystem structure and function through the release of top-down control (Christensen et al., 2014). Marine mammals are examples of these top-down controllers and are often considered as competitors of humans, since they share the same food (Kaschner and Pauly, 2005; Morissette, 2007; Plagányi and Butterworth, 2002; Read, 2008). In current scenarios, where fishing frontiers are moving further and many marine mammal species are recovering, the perception of a significant competition between marine mammals and fisheries has motivated different studies in order to understand how

* Corresponding author at: Instituto de Biología Marina y Pesquera "Almirante Storni" (IBMPAS), Universidad Nacional del Comahue, Güemes 1030, R8520CXV San Antonio Oeste, Argentina. Tel.: +54 2920 430764; fax: +54 2920 421002.

E-mail addresses: matiocre@gmail.com, matiocre@ibmpas.org (M. Ocampo Reinaldo).

they interact and to prevent future conflicts (Cronin et al., 2014; DeMaster et al., 2001; Harkonen et al., 2012; Harwood and Croxall, 1988). Although competition between marine mammals and fishing fleets is difficult to quantify, previous studies have shown some degree of direct impact between them (Bergamino et al., 2012; Morissette, 2007). However, this competition is entangled in a more complex web of interactions where indirect competition may be relevant (Trites et al., 1997; Yodzis, 1998).

On the Argentine Continental Shelf (ACS), the Argentine hake (AH) *Merluccius hubbsi* is one of the most important fishery resources in terms of landings volumes and its two main stocks were severely fished and are considered overexploited (Aubone et al., 2004; Vaz-dos-Santos et al., 2010). The San Matías Gulf (SMG) is a semi-enclosed fished ecosystem that hosts a third stock of Argentine hake. Several studies have shown that this stock completes its life cycle within the gulf, constituting an independent demographic unit (Di Giacomo et al., 1993; González et al., 2007; Machado Schiaffino et al., 2011; Sardella and Timi, 2004). This species has also shown a size-structured intraspecific predation, where the larger cannibals prey over the commercially profitable medium-sized hakes and the latter actively feed over young-of-the-year juvenile hake (Ocampo-Reinaldo et al., 2011). The hake fishery started in 1971 with medium-sized industrial bottom trawlers, while industrial and artisanal long-liners joined 25 years later (González et al., 2007). While both fleets are aimed to capture hake, they affect a different range of fish sizes: trawlers catch all the size range from juveniles (which are discarded) to larger hakes (Ocampo Reinaldo, 2010; Romero et al., 2010), long-liners catch mostly large hakes with no significant discards (González et al., 2003, 2007; Romero, 2011).

The SMG also hosts several permanent settlements of South American sea lions (SASL) *Otaria flavescens* and one temporary settlement of South American fur seals *Arctocephalus australis* (Svendsen et al., 2013). During the 20th century the SASL population was severely reduced in this ecosystem due to intense hunting, but in the 1970's conservation was promoted and hunting was banned (Crespo and Pedraza, 1991; Dans et al., 2004). As a consequence, SASL have been slowly recovering, until the 1990's when rapidly rebuilt their populations (overall ~5.7% per year). Recent studies indicate that they have high consumption rates and feed mostly over commercially profitable medium-sized and juvenile hakes (Drago et al., 2009; Romero et al., 2011).

In this situation, with SASL apparently competing with the fishery for the same resources is important to quantify the potential synergistic effects of SASL conservation, fishing activity and hake cannibalism over the food web. In this sense, the assessment of the SMG ecosystem needs to address these effects using the same framework. The construction of an ecosystem energy flow model in a "pristine condition" provides such a framework where baseline interactions between components of the ecosystem can be quantified. Changes in the ecosystem state and structure from the past to the present can be simulated to better understand the processes that underlie the observed patterns of abundance of important species.

This study is based on a reference steady state model of the SMG, for the time when the demersal fishery had not been developed yet and the SASL population was severely depleted (1970). Also, the model was then used to explore along four decades the ecosystem effects of a new and growing hake fishery paralleled by the rise of SASL population due to conservation measures.

The aim of this study was to evaluate the effect of a growing SASL population over the Argentine hake resource of SMG, considering the changes in the fishing activity as well as the size-structured cannibalism within the hake population. The evaluations were based on long-term time series of AH and SASL biomass using the "Eco-path with Ecosim" dynamic modelling approach.

2. Methods

2.1. Study area

The study area has been set for modelling purposes over the operative area of the San Matías Gulf (SMG) trawl fishery (41°30'S and 64°30'W at the centre of the area, approximately 10,000 km²), which covers almost the entire gulf from the coasts to its entrance (Fig. 1). This semi-enclosed area is deeper than 90 m, with a maximum of 200 m in the central area, and the continental shelf on the eastern side forms an open basin with a mean depth of 50–70 m at the entrance. The general circulation pattern in spring-summer is dominated by a cyclonic gyre, located at the northern half of the basin (70 km diameter approximately, Piola and Scasso, 1988), which in combination with a seasonal frontal system in summer determines the relative isolation of the gulf water masses (Gagliardini and Rivas, 2004; Piola and Scasso, 1988; Scasso and Piola, 1988; Williams et al., 2010).

In terms of biological components, the SMG sustains a diverse food web. Zooplankton is dominated by sub-antarctic euphausiids (*Euphausia lucens*, *E. vallentini*) and the sub-tropical *Nematoscelis megalops* and tropical *Thysanoessa gregaria*, which are found with different abundances and frequencies of larval stages in relation to the ACS waters, supporting the isolation hypothesis of the SMG waters (Curtolo et al., 1990).

Similarly, over 23 species of planktonic cnidarians have been found with a characteristic assemblage composition, highlighting the presence of a siphonophore *Pyrostephos vanhoeffeni*, previously known as endemic to Antarctic and sub-Antarctic waters (Guerrero et al., 2013). On the other hand, as additional evidence of the isolation of this ecosystem, the Argentine red shrimp *Pleoticus muelleri* have not been a significant benthic component within the SMG, while over other coastal areas of the ACS (e.g. San Jorge Gulf) it is a very important fishery resource. Small pelagic fishes such as anchovy *Engraulis anchoita* are present with a high biomass, but no fishery has been developed to target them (González et al., 2004; Hansen, 2007; Rojo and Silvosa, 1969). The demersal fish community is dominated by the Argentine hake (AH) both in terms of biomass and landings. Alongside with its highly intra-cohort and inter-cohort cannibalistic behaviour, this species feeds over a variety of preys changing its diet during its lifetime (Prenski and Angelescu, 1993; Ocampo-Reinaldo et al., 2011). Many other fishery species that are likely to play an important role in the food web (e.g. short-finned squid *Illex argentinus*) show dramatic inter-annual abundance variations for unclear reasons (Romero, 2011). The SMG ecosystem also represents an independent management unit, with their demersal fisheries and conservation areas managed exclusively by the Río Negro Province Administration. Within this ecosystem, the fishing activity is performed mainly by industrial bottom trawlers aimed to catch the AH (up to 80% of the annual landings) followed by the silver warehou *Serioloella porosa* in recent years (Ocampo Reinaldo et al., 2013; Romero et al., 2013). However, more than 15 other fish species have commercial and/or ecological value and are mostly captured by trawlers as by-catch. The landings composition has changed a few times in the fishery history, due to market drivers and/or variations in the fishing strategies rather than changes in the abundance of the target resources (Romero, 2011; Romero et al., 2013). A mid-water near-bottom long-liners industrial fleet joined in 1996, but after 4 years was banned, allowing thereafter only artisanal smaller boats with similar gears (González et al., 2007). A third industrial jigger fleet has operated sporadically over the SMG, with highly variable inter-annual effort depending on the occasional abundance of short-finned squid (1994–1999, 2000 and 2003) (Fig. 2; Official logbook records of the Fishery Directorate of Río Negro province, Millán, 2009).

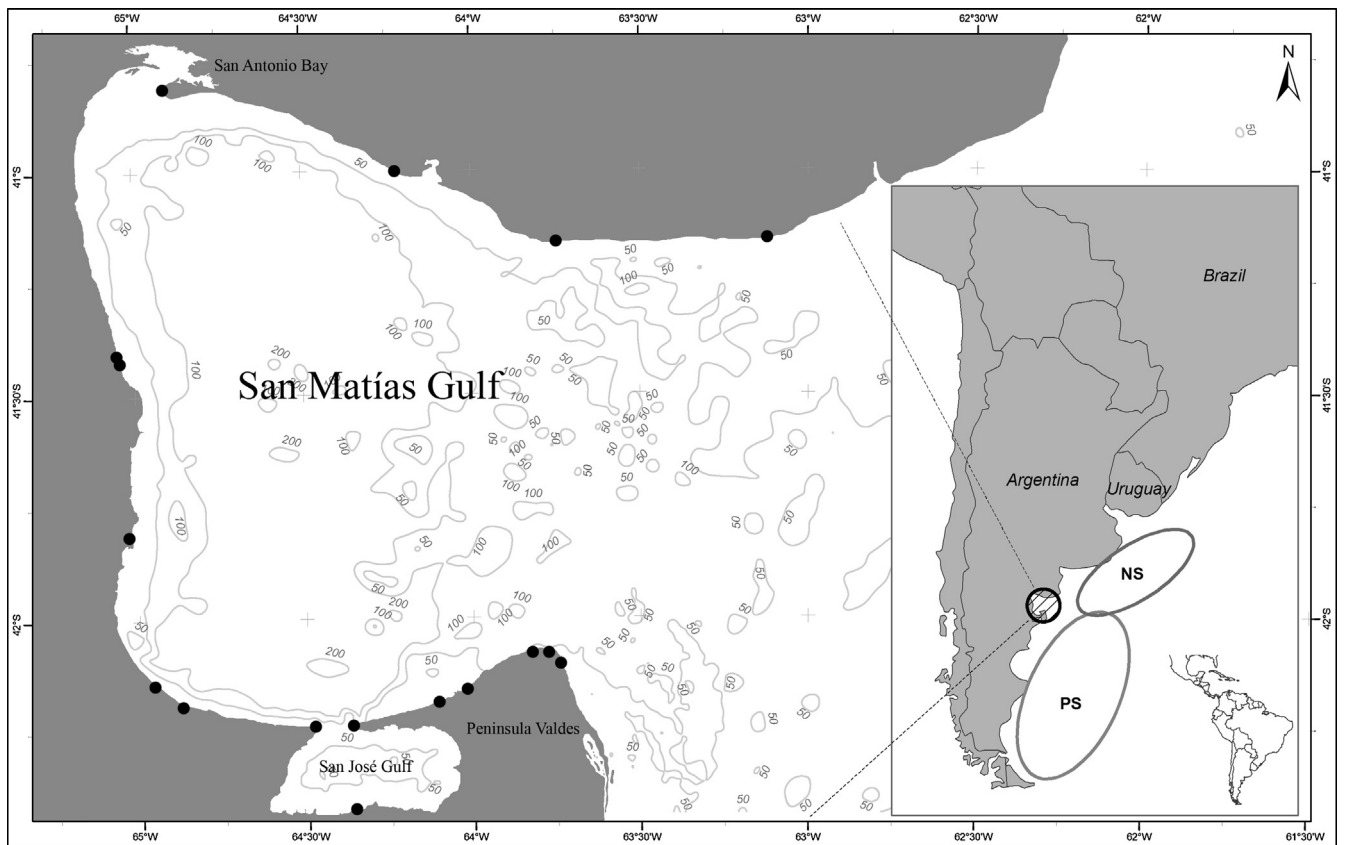

Fig. 1. Location of the San Matías gulf and the three stocks of *Merluccius hubbsi* in Argentine waters (PS: Patagonic stock, NS: Northern stock). Black solid points highlight the location of the current settlements of *Otaria flavescens* within the gulf.

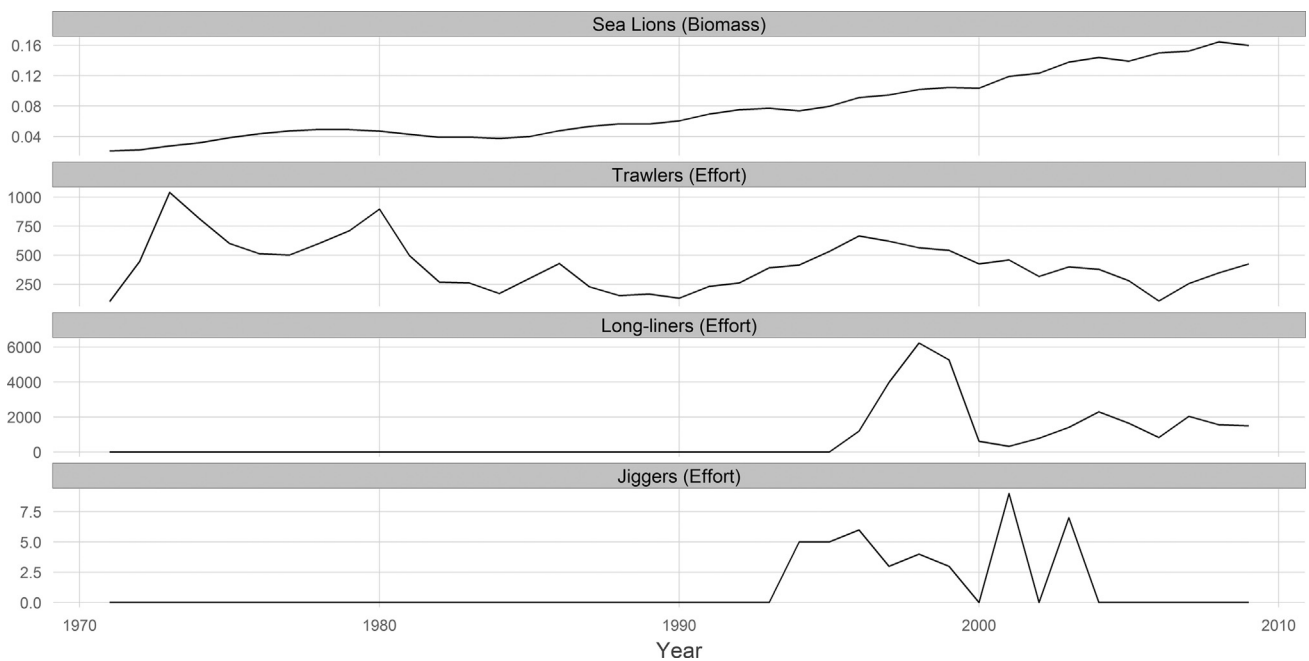

Fig. 2. Forcing series to run the simulations of the demersal food web in the San Matías gulf, using ECOSIM. Sea Lions biomass (t km^{-2}) has been increasing alongside the growing fishing effort in the fishery (fishing trips). Changes in trawlers effort in the 1980s were due to the fishermen turned opportunistically to catch highly valuable scallops, while in the 2000s were due to macro-economy related disadvantages. Also, in the 1990s the discard ratio of Argentine hake doubled the previous tendency due to ineffective mesh-size regulations (not showed, Romero et al., 2010). Effort changes in long-liners were due to the opening and banning of the industrial fishery, while nowadays only remain artisanal smaller boats. Effort changes of Jiggers are related to an opportunistic fishery strategy, due sporadic high abundances of short-finned squid. The effort series have not been used to force the simulation and are only shown to illustrate the changes in the history of the fishery. Details of the actual fishing forcing series (catches data) are given in Table 2.

The abundance of top predatory SASL has been increasing since 1970 from a small number of individuals to several permanent reproductive settlements with a total number of approximately 18,000 individuals in 2009 (unpublished data, Fig. 2). This species feeds mostly over juvenile and medium-sized hake, along other less preferred/abundant species (Romero et al., 2011).

2.2. Modelling approach

The mass balanced network model Ecopath was used in this study (Christensen et al., 2008). In Ecopath, species can be considered individually, or pooled together into functional groups. In the model, each group ingests food from the system at a specific rate, egests unassimilated food, respire part of the assimilated energy and produces biomass as prey for other model compartments or/and as export to the fishery. Each group is represented by its biomass and the groups are linked by a diet matrix through their trophic interactions. The basic Ecopath model is a closed system of balanced between the functional groups of an ecosystem and the full methodology can be found in the user's guide (Christensen et al., 2008, www.ecopath.org).

A model was constructed to represent the food web in the SMG before the beginning of the fishery (1970). The functional groups considered were based on the available (and reconstructed) information from the subsequent fishery (landings/discards, 1971–2009) and several surveys between 1970 and 2009. As a result, 23 groups were identified from high predators (e.g. marine mammals and sharks) to phytoplankton (Table 1). These groups were selected in order to have a representation of all trophic levels of the “demersal-pelagic food web” of the SMG. In some cases, functional groups are disaggregated to the species level when they are abundant and/or have commercial/ecological value and the available information allow for such a disaggregation. Other groups represent an aggregation of several taxa. In those cases, data of one representative and/or more abundant species

are used to characterize the group (i.e. *O. flavescens* as representative of the “Sea lions” group). Considering the strong ontogenetic changes in diet and the cannibalistic behaviour of the AH in the SMG (Ocampo-Reinaldo et al., 2011), this group was split into juvenile young-of-the-year (<23 cm of total length), medium-sized (between 24 and 53 cm, already mature) and large hake (more than 53 cm/6 years old, with females reaching larger sizes than males at the same age; Ocampo Reinaldo, 2010).

The model was constructed by means of Ecopath with Ecosim version 6.4.3 software (EwE, Christensen and Pauly, 1992; Walters et al., 1997; www.ecopath.org).

There are two principal equations in the ECOPATH model. The first, Eq. (1), describes production within a group (i):

$$P_i = Y_i + B \times M2_i + BA_i + E_i + P_i \times (1 - EE_i) \quad (1)$$

where P_i is total production, Y_i is total fishery catch, B_i is biomass, BA_i is biomass accumulation, $M2_i$ is total predation rate, E_i is net migration rate (emigration–immigration), and $P_i \times (1 - EE_i)$ is other mortality (MO_i) with EE_i the ecotrophic efficiency which represents the total fraction of the production that is either eaten by predators or exported from the system, including in the form of fishery catch (Christensen and Walters, 2004).

The second basic Eq. (2), consists of balancing the energy within each group or box:

$$Q_i = P_i + R_i + U_i \quad (2)$$

where Q is consumption, P production, R respiration and U unassimilated food.

This results in a series of simultaneous equations created (equivalent to the number of groups in the model), and solutions for the equations were calculated based on the assumption of mass balance within the system (see Christensen et al., 2008). The routine solves for one of four parameters for each group: biomass, production/biomass ratio (P/B), consumption/biomass ratio (Q/B) or ecotrophic efficiency (EE). Three of the four parameters must be

Table 1
Functional groups and the corresponding species names (or class/order when appropriate) included in this study of the San Matías gulf. The groups in bold compound the multistanza group of Argentine hake. The underlined components are the most representative of the functional group.

Group name	Common names species name or phylum/class/order
Dolphins	Common dolphin <i>Delphinus delphis</i> , Dusky dolphin <i>Lagenorhynchus obscurus</i>
Sea Lions	<u>South American sea lion</u> <i>Otaria flavescens</i> , South American fur seal <i>Arctocephalus australis</i>
Other rays	Apron ray <i>Discopyge tschudii</i> , Argentine torpedo <i>Torpedo puelcha</i> , Eagle ray <i>Milyobatis spp</i>
Large rays	Yellownose skate <i>Dipturus chilensis</i> , La Plata skate <i>Atlantoraja platana</i> , spotback skate <i>A. castelnaui</i> , smallnose fanskate <i>Sympteria bonapartii</i>
Small rays	Eyespot skate <i>A. cyclophora</i> , <i>Psammobatis spp</i> , Bignose fanskate <i>Sympteria acuta</i>
Large sharks	Broadnose sevengill shark <i>Notorhynchus cepedianus</i> , Smooth hammerhead <i>Sphyrna zygaena</i> , Sand tiger shark <i>Carcharias taurus</i> , Copper shark <i>Carcharhinus brachyurus</i>
Medium-sized sharks	Angular angel shark <i>Squatina guggenheim</i> , Picked dogfish <i>Squalus acanthias</i> , Tope shark <i>Galeorhinus galeus</i>
Juvenile sharks	Juvenile of Large and medium-sized sharks
Narrownose smooth-hound	<i>Mustelus schmitti</i>
Benthic-demersal fish II	Argentine sandperch <i>Pseudoperca semifasciata</i> , Argentine seabass <i>Acanthistius patachonicus</i> , Wreckfish <i>Polyprion americanus</i>
Flounders	<i>Paralichthys isosceles</i> , <i>P. patagonicus</i> and <i>Xistreureys rasile</i>
Benthic-demersal fish I	Juvenile of <i>Pseudoperca semifasciata</i> and <i>Acanthistius patachonicus</i> , <u>Pink cusk-eel</u> <i>Genypterus brasiliensis</i> , Patagonian hoki <i>Macruronus magellanicus</i>
Plownose chimaera	<i>Callorhynchus callorhynchus</i>
Large hake	Argentine hake <i>Merluccius hubbsi</i>
Medium-sized hake	
Juvenile hake	
Pink cusk-eel	<i>Genypterus blacodes</i>
Patagonian hoki	<i>Macruronus magellanicus</i>
Medium-sized pelagic fishes	Parona leatherjacket <i>Parona signata</i> , Southwest Atlantic butterfish <i>Stromateus brasiliensis</i> , Silver warehou <i>Seriola lalandi</i> , Chub mackerel <i>Scomber japonicus</i>
Small pelagic fishes	Argentine anchovy <i>Engraulis anchoita</i> , Rough scad <i>Trachurus lathami</i>
Squids	Short-fin squid <i>Illex argentinus</i> and South American long-fin squid <i>Loligo sanpaulensis</i> , Patagonian squid <i>L. gahi</i>
Benthic organisms	Argentine red shrimp <i>Pleoticus muelleri</i> , benthic crustaceans, Bivalvia, Polychaeta and other benthic organisms.
Jellyfishes	Ctenophora, Salpidae, Hydrozoa
Zooplankton	<i>Euphausiids</i> , Copepods, Cladocera, Ostracods
Phytoplankton	Diatoms and Dinoflagellates
Detritus	–

entered to calculate the one unknown. This means that the basic model parameters required include biomass estimates, diet compositions, assimilation efficiencies, catch rates (where applicable) and three rate measurements (consumption, production and mortality).

If all of these data are available, the EE of each group can be calculated by the model. For the model as a whole, the energy input and output of all living groups must be balanced (Christensen et al., 2008). In Eq. (2), only the production term of a group is included. To ensure balance within each group, Eq. (1) is used.

2.2.1. Checking the mass-balance in each group

Models were balanced by checking the values of EE and of the gross efficiency of food conversion (GE) for each group. EE ranges between 0 and 1, while GE, which is equal to P/Q , ranges between 0.1 and 0.35. Following criteria presented in Christensen et al. (2008), changes in input data B , P/B or diet were performed until acceptable runs were obtained.

Despite the fact that the model is representative of the ecosystem in a time with no fishing activity, in order to facilitate the introduction of variable fishing effort in the ECOSIM module the model was balanced with a consideration of a very low incipient fishing effort on the species of the system, representing 1% of the maximum value for each fleet in recent years of full system exploitation.

2.3. Data

Biomasses of some groups were available from swept area surveys performed between 1970 and 1974. In some cases, biomasses estimates were reconstructed from abundance estimates by extrapolation, using empirical equations. For Sea Lions

and the 3 groups of hake the abundance correspond to the year 1970 (Romero unpublished data, Rojo and Silvoza, 1970), whereas some other groups correspond to an approximated/reconstructed values base on 1974 data: Large rays, Medium-sized sharks, Plownose chimaera and all bony fishes except Benthic-demersal fish I and Small Pelagic fishes (unpublished data). Taking into account that the fishery operated heavily by 1973, those biomass values were slightly increased to balance the model based on hake data from 1970. When no biomass or abundance information was available, the Ecopath estimations of biomass were used by fixing the EE values (Dolphins, Squids, Jellyfishes and zoo/phytoplankton; Table 2).

The groups of hake compose a “multistanza group”, where the leading age group is Medium-sized hake and the leading mortality group is Large hake. The values of the total mortality rate $Z = P/B$ were calculated from reconstructed catch curves data from surveys performed before the beginning of the fishery (1969 and 1970, then with Z equivalent to the natural mortality rate M , Ocampo Reinaldo, 2010; Table 2).

Rate estimates of the other groups were taken from the literature or calculated using empirical equations (Allen, 1971; Palomares and Pauly, 1998). All rate estimates are given in Table 2.

Trophic linkages were made from published and unpublished information based on studies on diet (Dolphins: Romero et al., 2012; Sea Lions: Romero et al., 2011; Large rays: Collier, 2012; Estalles, 2013; Benthic-demersal fish I and II: González, 1998; Plownose quimera: Di Giacomo, 1990; AH: Ocampo-Reinaldo et al., 2011, Squids: Crespi-Abril, 2010). Most of the data were collected in recent years and were assumed to be representative of the entire time series. The input parameters of diet for each functional group are provided in Appendix A.

The EwE model provides a framework to assign a measure of data quality to the parameters used in the model: the ‘Pedigree’.

Table 2

Model parameters corresponding to the demersal food web in the San Matías gulf in 1970. Bold numbers indicate parameters estimated by Ecopath. TL: Trophic level. The letters indicate the type of time series of each group ($t \text{ km}^{-2} \text{ year}^{-1}$) used to calibrate the simulation with Ecosim. Forcing series: ^a trawlers landings; ^b trawlers discards, ^c long-liners landings; ^d jiggers landings. Fitting series: ^e Biomass estimations. The biomass estimation of Sea Lions was also used as forcing series. Discards for long-liners and jiggers are negligible. Asterisks (*) highlight groups were the species were fully discarded until some point when the economy/market changed and were considered profitable.

Group name	TL	Biomass ($t \text{ km}^{-2}$)	Production/biomass (year^{-1})	Consumption/biomass (year^{-1})	Ecotrophic efficiency	Production/ consumption	Omnivory index
Dolphins ^{b,e}	3.94	0.008	0.85	10	4.5094E – 05	0.0850	0.2243
Sea Lions ^{b,e}	4.54	0.021	1.014	14	1.0000E – 04	0.0724	0.1586
Other rays ^{b,e}	3.25	0.306	0.27	4.09	0.0000E + 00	0.0660	0.5164
Large rays ^{a,b,e}	4.26	0.553	0.45	3.233	2.1352E – 06	0.1392	0.8115
Small rays ^{a,b,e}	3.02	0.447	0.55	4.753	7.4950E – 01	0.1157	0.0291
Large sharks ^{a,e}	3.52	0.018	0.28	2.263	1.5110E – 10	0.1237	0.4416
Medium-sized sharks ^{a,c,e}	3.62	0.762	0.615	3.632	6.2000E – 03	0.1693	0.5588
Juvenile sharks ^{b,e}	3.43	0.118	0.4	3.485	9.9900E – 01	0.1148	0.7043
Narrownose smooth-hound ^{a,b,c,e}	3.68	0.153	0.6	4	8.4710E – 07	0.1500	0.6514
Benthic-demersal fish I ^{a,b,c,e}	3.96	1.304	0.435	3.14	1.4700E – 02	0.1385	0.8964
Flounders ^{a,b,e}	4.11	0.339	0.97	3.7	9.0000E – 01	0.2622	0.9996
Benthic-demersal fish II ^{b,e}	3.33	1.327	1.29	6.95	9.9900E – 01	0.1856	0.3687
Plownose chimaera ^{a,b,c,e}	3.44	0.464	0.4	3.485	2.6110E – 02	0.1148	0.3254
Large hake ^{a,c,e}	4.64	3.227	0.688	1.358	1.8000E – 03	0.5064	0.1767
Medium-sized hake ^{a,c,e}	4.05	6.237	0.770	2.889	9.4850E – 01	0.2664	0.2274
Juvenile hake ^{b,e}	3.54	0.098	0.880	11.570	9.9900E – 01	0.0761	0.3891
Pink cusk-ee ^{a,c,e}	3.23	0.947	0.99	3.076	2.2090E – 01	0.3218	0.2993
Patagonian hoki ^{a,e}	3.25	3.861	0.69	3.892	2.5790E – 01	0.1773	0.2847
Medium-sized pelagic fishes ^{b,c,e}	3.31	8.953	1.25	6.49	4.5100E – 01	0.1926	0.7776
Small pelagic fishes ^e	3.01	10.343	1.943	12	9.9000E – 01	0.1619	0.2576
Squids ^{b,d}	3.19	1.898	2.977	6.1	9.0000E – 01	0.4880	0.8395
Benthic organisms	2.02	9.780	4.12	12	5.8560E – 01	0.3433	0.0316
Jellyfishes	2.96	2.765	9.56	21.9	9.0000E – 01	0.4365	0.2458
Zooplankton	2.01	9.059	19.921	41.575	9.0000E – 01	0.4792	0.0101
Phytoplankton	1	3.577	105		9.9900E – 01		
Detritus	1	1			5.5520E – 01		

Using this framework, each parameter is assigned a value to measure its perceived quality (Appendix A). A qualitative index was used to describe the data source for each parameter (Biomass, P/B and Q/B) for each functional group and then a general 'Pedigree index' was obtained.

2.4. Ecosystem network analysis

Trophic network analysis was performed after mass-balance was achieved. The trophic level (TL) for each functional group was calculated from its diet, as the weighted average of the trophic levels of its prey.

Flows and biomasses in the system were aggregated by discrete TLs using the Lindeman spine routine of the software. The Lindeman spine illustrates the net amount each TL receives from the preceding one, as well as the amounts it creates through respiration, exports, detritus for recycling, and net production for transport to the next TL. The primary producers and detritus compartments are merged into the first TL and therefore calculating the transfer efficiencies between subsequent TLs, allowing to the calculation of the trophic efficiency of each level and for the food web as a whole (Christensen and Walters, 2004).

The System Omnivory Index was calculated as the average of the individual Omnivory Indices of the consumer groups, weighted by the logarithm of their consumption (Christensen and Walters, 2004).

The Mixed Trophic Impact (MTI) routine was applied to evaluate the possible impact that a very small change in biomass of one group would have on the biomasses of all the other groups in the system (Ulanowicz and Puccia, 1990). Although this is a static analysis and does not account for temporal changes, the MTI can be used to infer possible impacts of biomass variations and to rank the model groups according their overall impact over the system.

Long-term changes were assessed by the calculation of the "fishing in balance" (FIB) Index using time series of catches (see *Time dynamic simulation*). This index was developed to address what may occur when the decline in the mean trophic levels of the fleets is attributable to the deliberate choice of targeting low trophic level species. If the choice to fish lower in the food web is deliberate, one would expect there to be an increase in the catch that is commensurate with the decline in TL of the fleets (Pauly et al., 1998). Additionally, long-term changes in TL of Sea Lion, the hake groups and the fleets were also analysed.

2.5. Time dynamic simulation

The temporal module Ecosim re-calculates the initial Ecopath snapshot for each time-step, taking into account a series of variations in fishing effort, biomass, and other factors. The Ecosim equation that models the biomass growth rate for each group (i) is:

$$\frac{dB_i}{dt} = q_i \sum_j Q_{ji} - \sum_j Q_{ij} + I_i - (M_i + F_i + e_i) \times B_i \quad (3)$$

where I_i and e_i are the immigration and emigration rates, respectively (zero in this system), M_i is the natural mortality and F_i is the fishing mortality (Christensen and Walters, 2004; Walters et al., 1997). The theoretical basis of Ecosim started with the typical Lotka–Volterra function that represents prey–predator interactions, modelled within EwE by a 'vulnerability' parameter, which represents the degree to which an increase in predator biomass will cause an increase in mortality for its prey. This parameter is linked to the carrying capacity for the predators. The simulation was fitted to several time series of data, considering the biomass of Sea Lions

and the catches of the fleets as forcing variables, while biomass data points of several species were used to fit the vulnerabilities matrix (Fig. 2, appendix A).

3. Results

3.1. Ecopath reference model

The balanced model comprised 4 trophic levels (TL, Table 2) with the top functional groups Large hake, Sea Lions, Large rays, Flounders and Medium-sized hakes (TL > 4). The other fish groups had a TL ranging from 3.01 to 3.96, alongside Dolphins and Squids (TL values of 3.94 and 3.19, respectively). Benthic organisms, Jellyfishes and Zooplankton had a TL < 3. The flow diagram resulting from the model represents each group with a circle that is proportional to the logarithm of its biomass (Fig. 3), along with all predator/prey interactions.

The ecotrophic efficiencies (EE) of top-consumers after balancing were low overall, ranging between $2.13E-06$ (Large rays) and 0.948 (Medium-sized hake) (not considering Flounders, with an EE of 0.9 previously introduced in the model to allow it to estimate the minimum biomass of the group). Excluding juvenile fishes groups (Juvenile hake, Juvenile sharks, Benthic-demersal fish I) in the mid- web, the EEs tend to be smaller when the TL is higher, concomitant with a decrease in predation mortality with TL.

The Lindeman spline summarize 10 discrete TLs in the SMG ecosystem. Since the magnitude of flows at trophic levels higher than the fifth TL is very low, representing only a small fraction of the flows associated with the top predators, these higher levels were omitted from further analyses (Fig. 4). The trophic flow from detritus to consumers is approximately a third that originated from primary producers. The transfer efficiency is higher at the first consumer TL, decreasing at higher TLs. Also, the values of "exports and catches" in each TL are very low, related to the simulated catches introduced in the model.

The Omnivory Index (OI) varied between groups, showing in general higher values at higher TLs, with exception of Dolphins, Sea Lions, Large and Medium-sized hake. This indicates a specialization of those groups that feed on a narrow range of trophic levels (e.g. Sea Lions, Large hake, Table 2), while others feed across several trophic levels (i.e Large Rays, Flounders).

The model pedigree index was 0.534 which fits into the range of overall acceptable quality, as discussed in previous studies (Gurney et al., 2014; Morissette, 2007; Pauly et al., 2000). The original inputs were further validated by the consistency of gross efficiency (GE) or P/Q values which were within the expected ranges by reference to the diet composition (except for of Zooplankton, Jellyfishes, Squids and Large hake, for which they are too high, Table 2).

Other general system attributes and metrics are given in Appendix A.

3.2. Mixed trophic impacts analysis

The Mixed Trophic Impact analysis (Fig. 5) highlights that trawlers positively impact the upper level consumers like Flounders, Large hake and Medium sized hake, and negatively impact Sea Lions and Large rays. Sea Lions showed a negative impact over Large hake, although Large hake is not an important prey of it. Large hake have a positive impact over long-liners and a negative impact over Medium-sized hake. Medium-sized hake have a positive impact over trawlers, long-liners and Large hake, whereas they have a negative impact over Dolphins, Sea Lions, Large rays, Large sharks, Narrownose-smooth hound, Juvenile hake and itself.

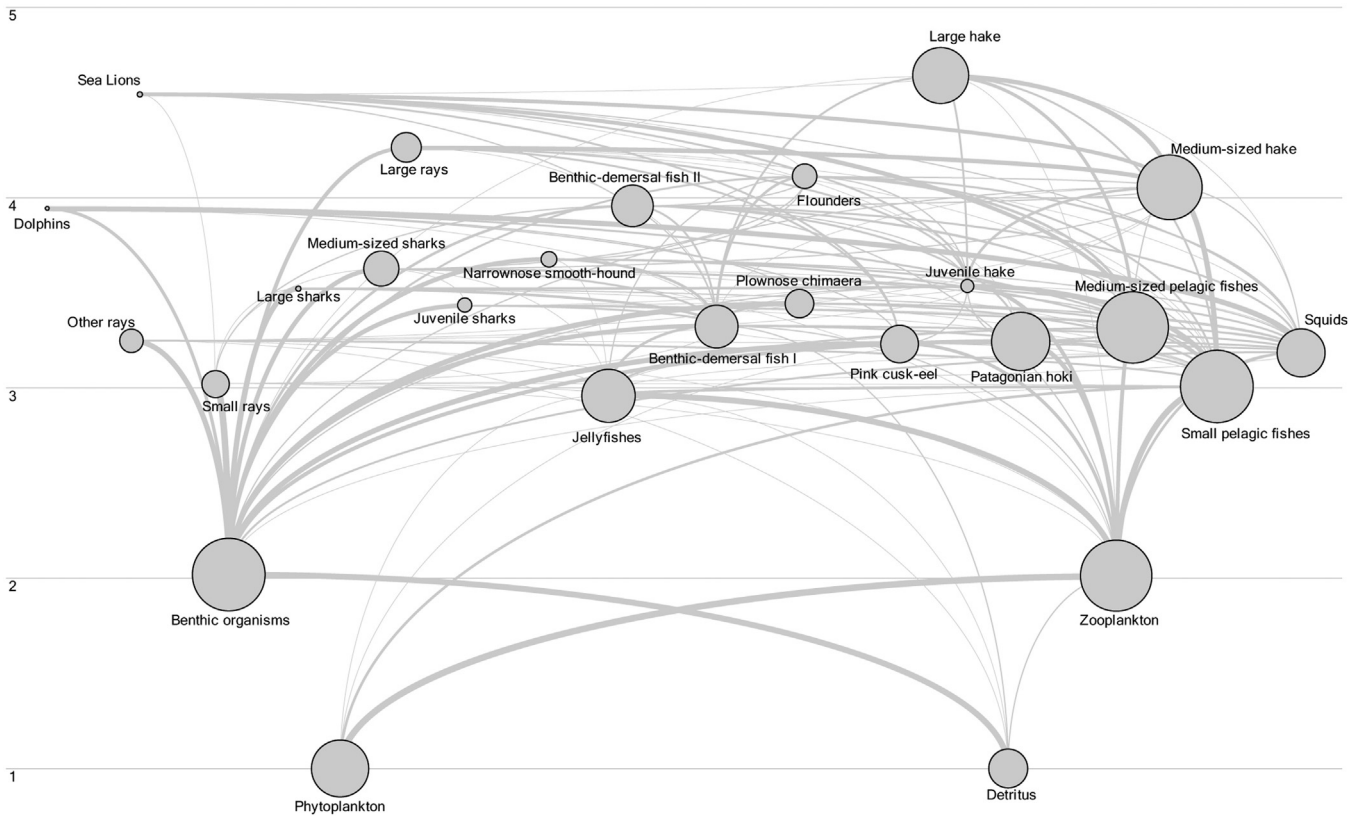

Fig. 3. Flow diagram corresponding to the demersal food web in the San Matías gulf in 1970. Each functional group is represented by a circle which is scaled to the biomass value (t); groups are distributed with increasing trophic level (TL) on the y-axis and all trophic linkages indicated by grey lines.

3.3. Time dynamic simulation

3.3.1. Biomass

The time series of biomass (reference) and catches (forcing) are given in Figs. 6 and 7, respectively. The vulnerabilities

values used to run the simulation are given in the Appendix A. The modelled biomasses by ECOSIM have followed reasonably well the biomasses tendencies of several groups, while Benthic-demersal fish II and Small pelagic fishes were poorly described.

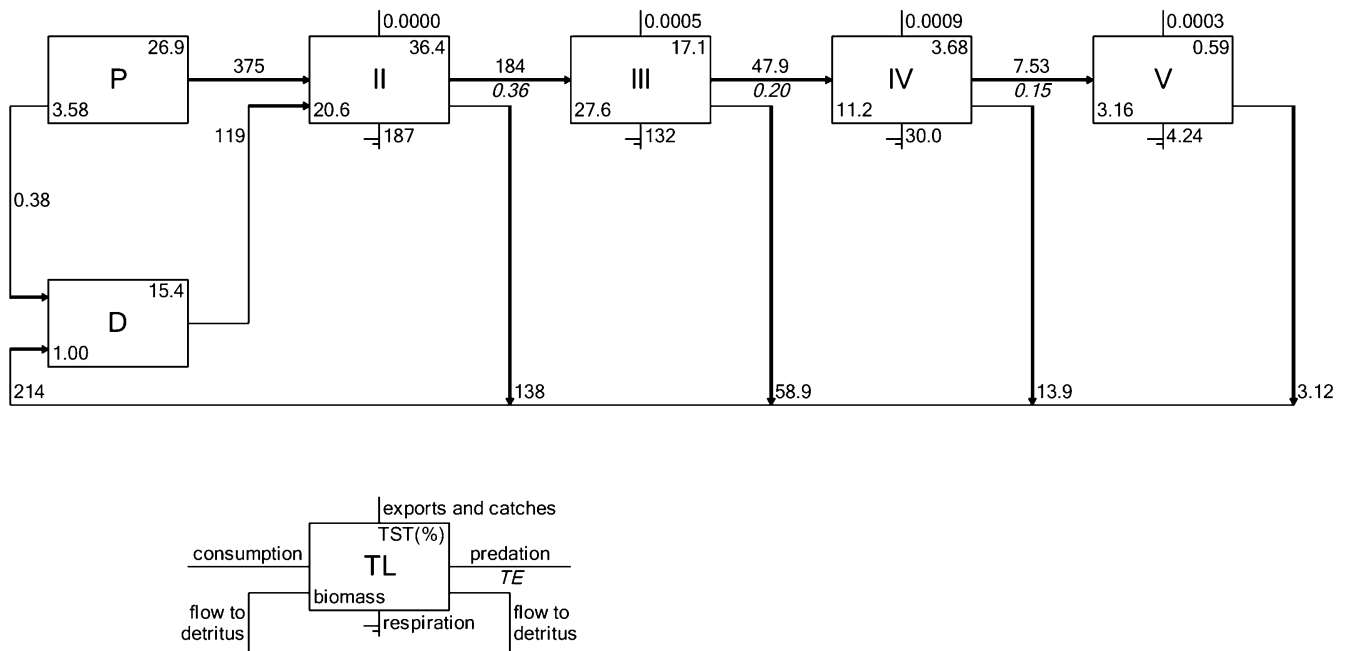

Fig. 4. The Lindeman spline corresponding to the demersal food web in the San Matías gulf in 1970: An aggregation of the flow network into a concatenated chain of transfers through trophic levels. The percentages in the boxes represent the trophic efficiencies according to the flows labelled in the reference box. P = primary producers, D = detritus, TST = total system throughput, TE = transfer efficiency, II-V = trophic levels (TL).

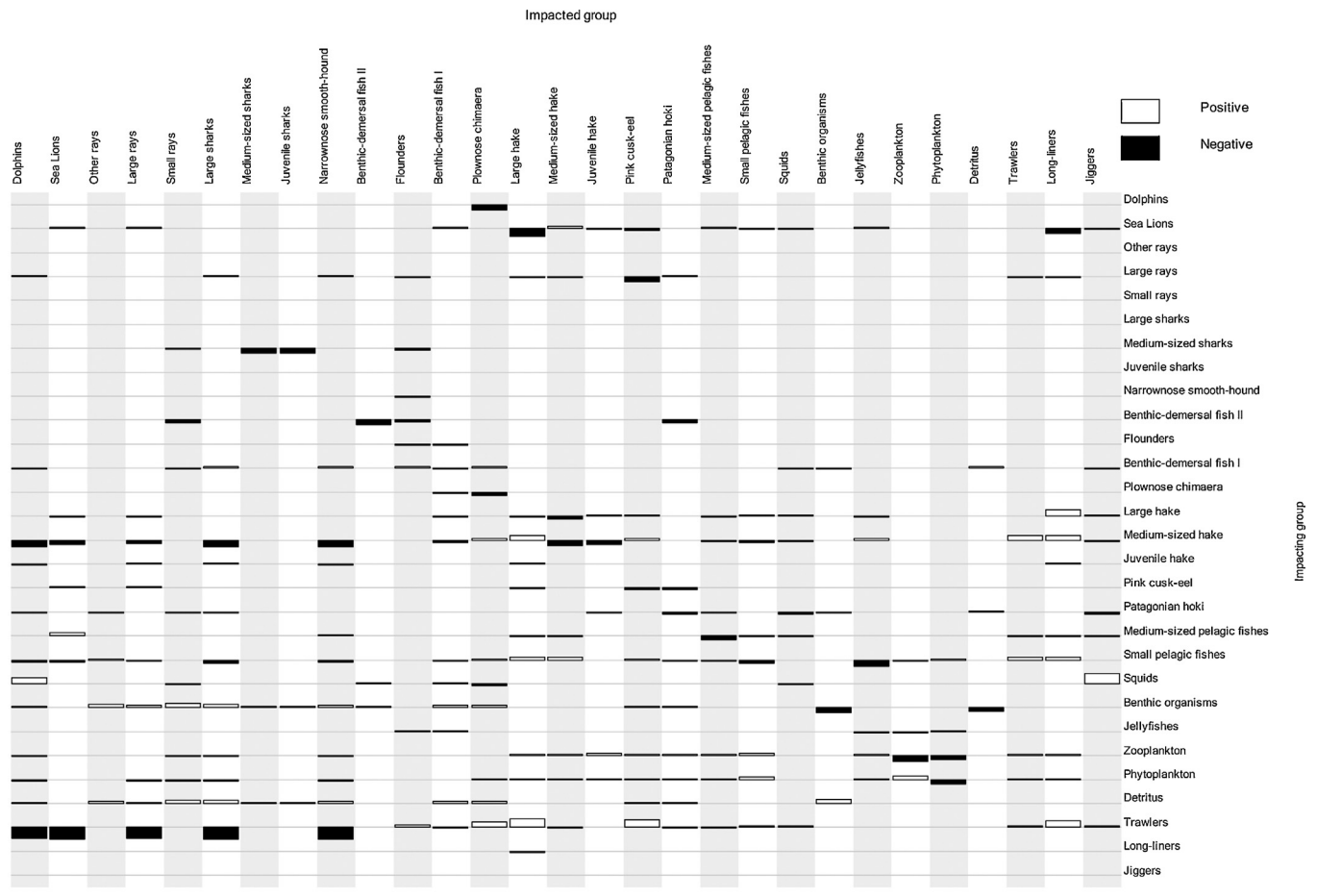

Fig. 5. Mixed trophic impact of each functional group on the other groups corresponding to the demersal food web in the San Matías gulf in 1970. A white rectangle above the baseline indicates positive impact, while a black rectangle below indicates negative impact. The dimensions of rectangles are comparable between groups, and represent the impact that an infinitesimal increase of the impacting group will have on the impacted groups.

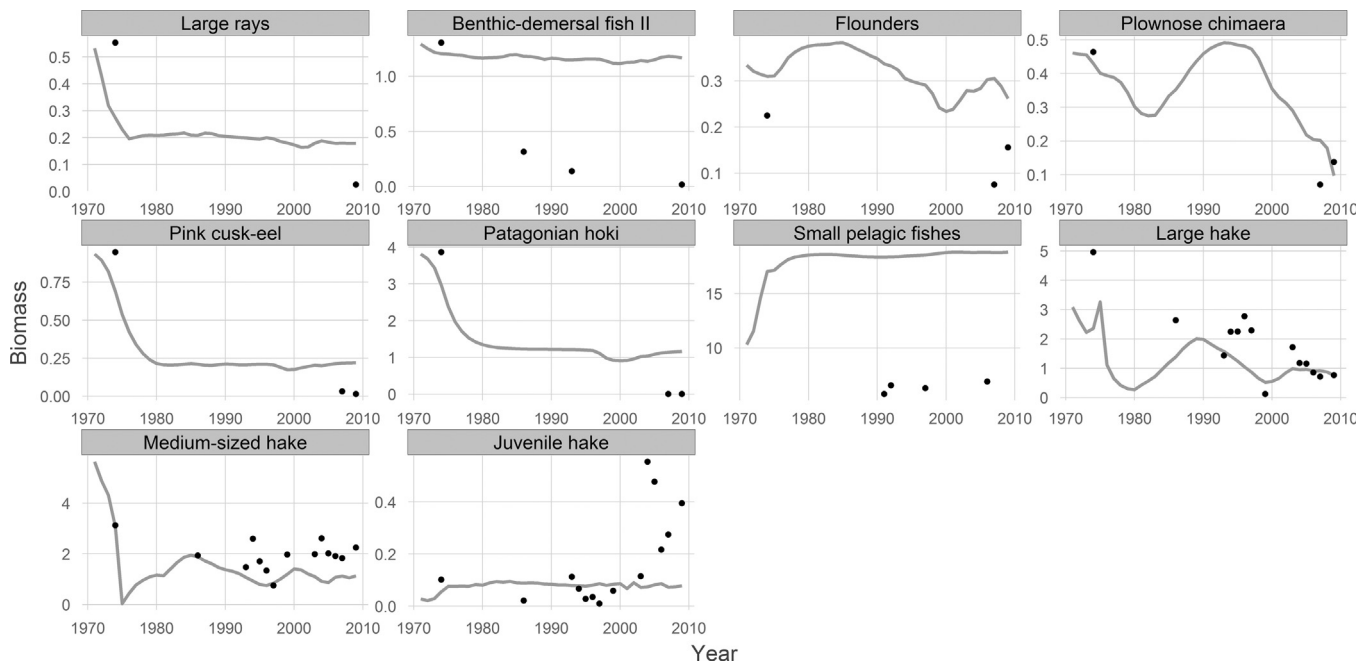

Fig. 6. Biomass ($t\ km^{-2}$) data series (points) used as references to fit the simulation. Lines represent the modelled biomass for each group. Only the groups with more than 2 data points are shown. All groups were weighed by 1 to fit the simulated biomass, except Large rays and Juvenile hake (weight = 0.5); Benthic-demersal fish II and Small pelagic fishes (weight = 0.75).

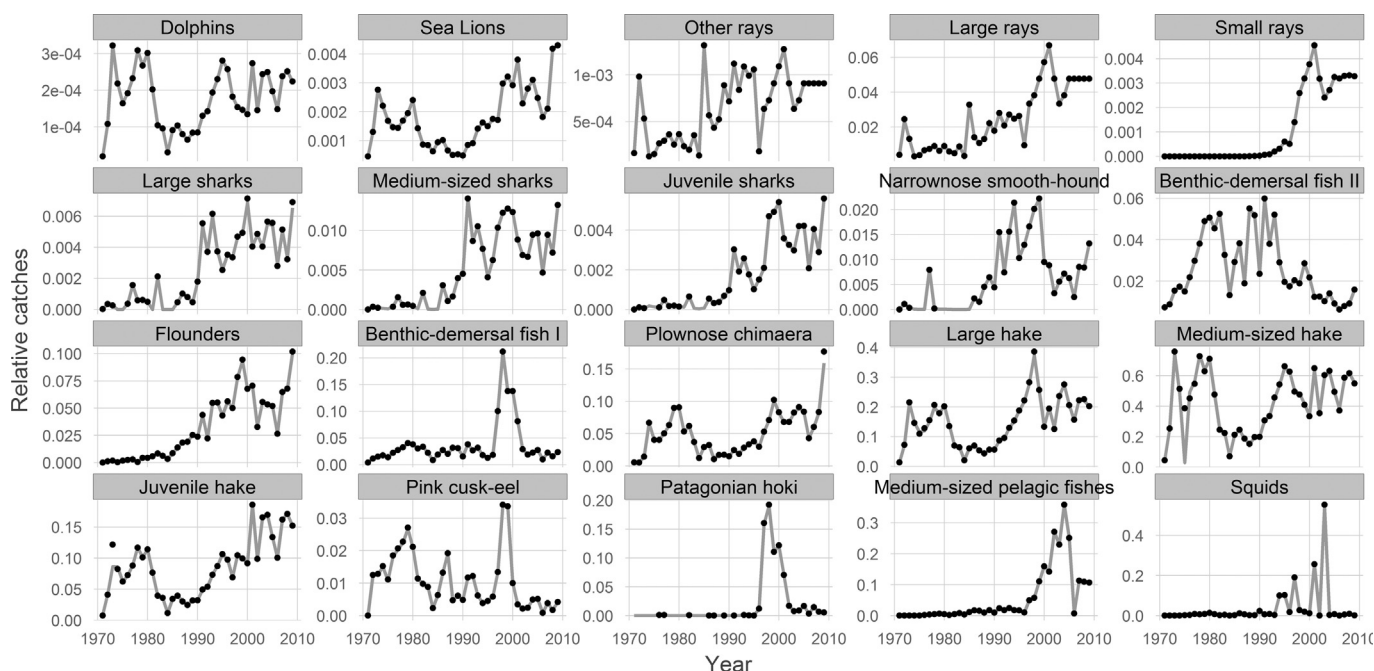

Fig. 7. Catches data series (points) used like forcing series to fit the simulation. Lines represent the modelled catches for each group.

3.3.2. TL and FIB indices

The trophic levels of Sea Lions, hake groups and the fleets (in which case refers to the “mean trophic level” of the fishery) have shown a drop within the 5 initial years at the beginning of the simulation. After that, Sea Lions, Medium-sized and Juvenile hake have not shown any significant variation. On the other hand, Large hake have shown changes in the TL: higher in the 1980's, lower in the 1990's and intermediate values in the 2000's (Fig. 8). Similarly, fleets have shown lower values between 1995 and 2005, recovering to the previous level after that.

The “fishing in balance” index (FIB) has shown variable positive values over the simulation, which may indicate different expansion periods of the fishery (Fig. 8).

3.3.3. Mortalities

The modelled mortalities of the 3 groups of AH have shown a variable composition in relation to 3 types of predators: the Fleets, Sea Lions and AH itself (Fig. 9). Large hake mortalities have been largely represented by fishing mortality, while no other group caused important predation mortality. The overall mortality on Medium-sized hakes has decreased in the early fishery from 0.6 in 1970 to 0.2 by 1976. Moreover, the mortality in 1970 was mostly represented by cannibalism of Larger and Medium-sized hake, while after the fishery started an important fishing mortality component was added and cannibalism mortalities dropped. Juvenile hake showed a similar pattern than Medium-sized hake, but the higher mortality is related to cannibalism performed by the latter. Fishing mortality on Juvenile hake has shown variations related to changes in the fishing effort, while cannibalism mortality performed by Large hake seems to have varied in relation to its abundance, from 0.5 at the beginning of the fishery to almost zero by the end of the simulation.

4. Discussion

The San Matías Gulf is relatively young (approximately 11000 years old; Isla, 2013) and constitutes a semi-enclosed ecosystem, with an interesting demersal community that remains relatively isolated from the Argentine Continental Shelf. Its community has

a well-known history supporting direct impacts and externalities from hunting, fishery development and conservation strategies of single species, among others. Due to those characteristics, the SMG is a suitable ecosystem to be analysed using the ecosystem-modelling framework.

In 1970 the estimated total biomass (excluding detritus) in the GSM (66.5 t km^{-2} over $10,000 \text{ km}^2$) was quite low compared to similar ecosystems (i.e. 122.7 t km^{-2} over 7200 km^2 in the northern Gulf of California, Morales-Zárate et al., 2004; 207.3 t km^{-2} over 103000 in the Gulf of Maine, Zhang and Chen, 2007). Estimated total system throughput of SMG in 1970 (TST, $1479.1 \text{ t km}^{-2} \text{ year}^{-1}$) was within the range of comparable ecosystems (i.e., higher than the northern Gulf of California and slightly lower than the Gulf of Maine). According to the ecosystem classification scheme proposed by Odum (1969), the value of the “total primary production/total respiration” (1.06) indicates that the SMG ecosystem may still be maturing, and there is more energy produced than consumed by the food web. Accordingly, the food web is dominated by the grazing rather than by the detritus pathway, where the lower TLs of the food web show the higher transfer efficiencies of the system.

The “Connectance index” (CI, 0.275) and “System Omnivory index” (SOI, 0.39) are also correlated with the system maturity since the food chain is expected to change from linear to web-like as the system matures (Odum, 1971). In the SMG, the value of CI is relatively low, suggesting a simplification of the food web and an immature system. However the CI (i.e. the number of actual links in relation to the number of possible links in the food web) is an ambiguous index and should be interpreted carefully. Moreover, the value of SOI is intermediate. These parameters are strongly linked with the structure of the model, thus its modifications by adding currently omitted groups (e.g. penguins, bacteria) may influence any topology-dependant metrics.

The high “overhead” (67.4%) also suggest that the system could still grow in terms of flows and biomasses, having high potential for adaptation and resilience capacity (Ulanowicz, 1986; Ulanowicz and Norden, 1990). Considering the low biomass of SASL and the consequent differences in respiration between the TLs number II and V (187 vs 4.24), it can be hypothesized that the ecosystem is

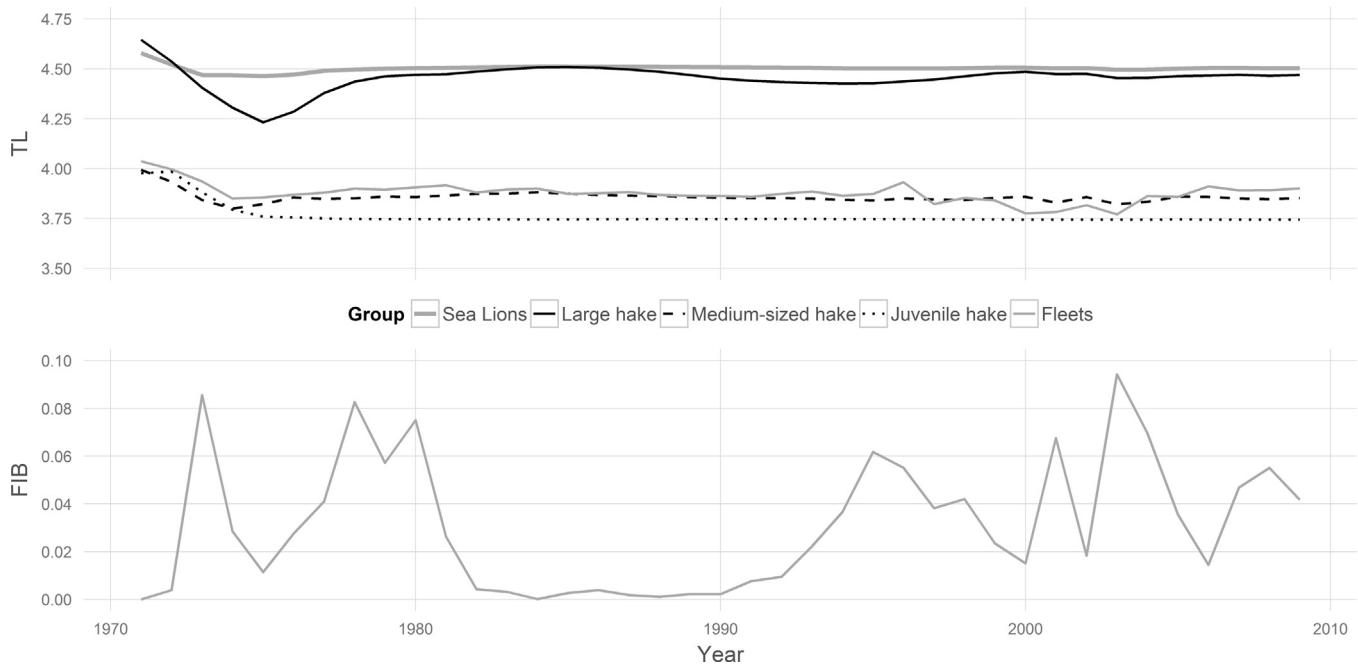

Fig. 8. Long-term change of: Above) trophic level (TL) of Sea Lions, hake groups and the fleets (trawlers, long-liners and jiggers combined); Below) “fishing in balance” index (FIB) corresponding to the demersal food web in the San Matías gulf.

not only in a development phase, but also recovering from a heavy perturbation due to the biomass removal of SALS.

At the beginning of the fishery, the mixed trophic impacts showed that trawlers had a positive effect over Large hake, other commercially bony fishes and even over long-liners, but a negative effect over several cartilaginous fishes and marine mammals. On the other hand, Sea Lions showed a negative impact over several bony fishes, particularly Large hake. These impacts over Large hake are counterintuitive considering that trawlers actively target it and Sea Lions do not feed on it. However, these unexpected

results may be explained by indirect effects: fleets favouring Large- and Medium-sized hake by removing their predators, and Sea Lions hindering Large hake by removing its preys.

Also, Large hake showed a negative impact over the groups of smaller hakes, probably related to cannibalism and competition for shared preys. The Medium-sized hake showed a negative impact over itself (probably related to intracohort cannibalism and competition) and over Juvenile hake, but a positive impact over Large hake (probably related to inter-cohort cannibalism, among other non-linear effects).

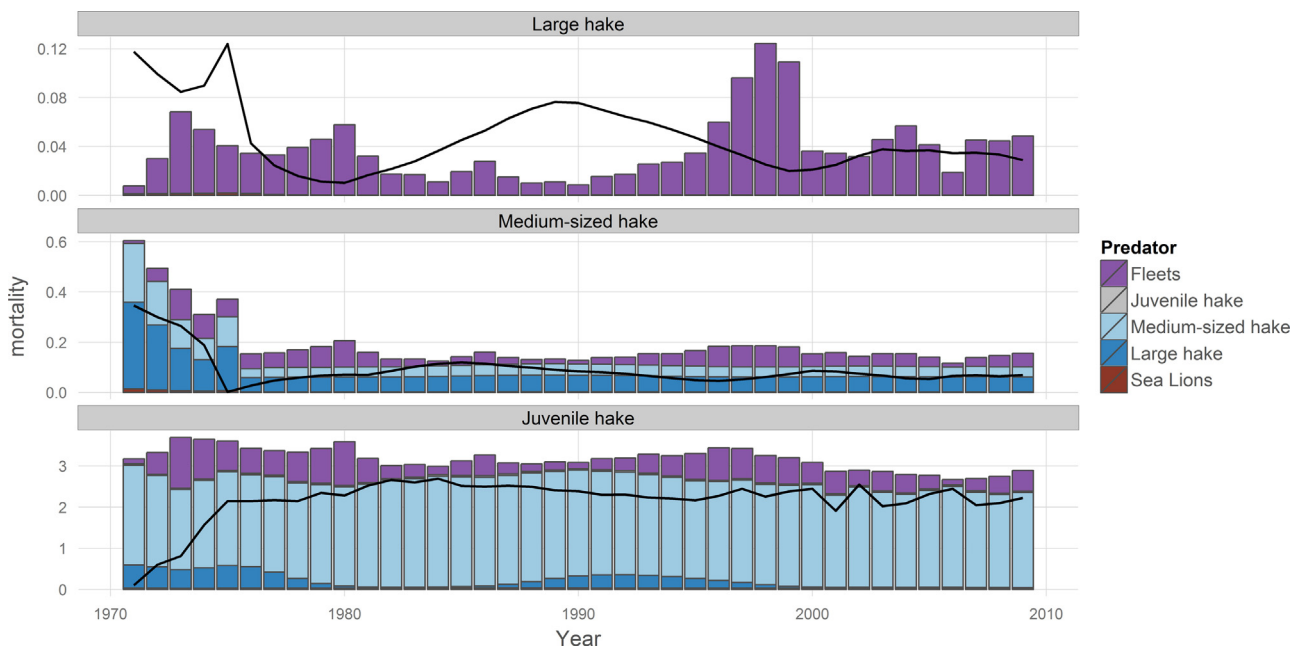

Fig. 9. Absolute mortalities composition (bars) performed by different predators over the 3 groups of hake from 1971 to 2009. The predators are represented by Sea Lions and the 3 groups of hake acting as cannibals (predation mortalities), and the fleets (fishing mortalities, trawlers and long-liners combined). The solid lines represent the relative biomass variations of each prey group of hake (rescaled from 0 to 1).

Trites et al. (1997) described that a “food web competition” for primary productivity may happen when marine mammals and fleets affect each other, even when their prey and catches do not overlap. In this study, Trawlers and Sea Lions partially overlap their “niches”, but the combined impacts between them are probably due to a complex mix of direct and indirect competition modulated by the size-structured cannibalism of AH.

The analysis of the Omnivory index of each group indicates that Dolphins, Sea Lions, Large and Medium-sized hake are the only “specialized” top predators in the food web, which feed over a narrow range of TL. Interestingly, this could be related to a diet based mostly on bony fishes, but the indices of hakes may be explained because of their cannibalism. It is important to point out that this “specialization index” is strongly related to the structure of the model and refers to “trophic levels consumption” rather than prey preference. The AH, as other *Merluccius* species (e.g. silver hake *M. bilinearis*, Koeller et al., 1989; Large Cape hake *M. capensis*, Macpherson and Gordo, 1994), is a typical generalist and opportunistic predator and usually feeds over abundant species. It has been suggested that cannibalism occurs in areas where food is scarce (Muto and Soares, 2011; Ocampo-Reinaldo et al., 2011; Ruiz and Fondacaro, 1997). By inter-cohort predation, larger hakes can take advantage of highly abundance smaller hakes that transfer energy up from lower trophic levels and, at the same time, maintaining a relative independence from the abundance oscillations of other fish species in the mid-web. For instance, estimated TL values of SASL and medium-sized AH using stable isotopes techniques in the area of the Patagonian stock are higher than the TL values obtained in this study (4.85 and 6.46, respectively, Ciancio et al., 2008), probably related to different availability and abundance of prey from more diverse mid- and upper trophic level food webs.

The TL of Sea Lions and the groups of hake showed a decrease at the beginning of the fishery, maintaining relative stable values over the four subsequent decades. Similarly, the mean trophic level of the three fleets combined showed an analogous pattern, with some variations between 1995 and 2005. This matches the years were jiggers and the industrial long-liners started their fisheries, with a different catch composition than trawlers (Romero, 2011). After 2000, artisanal long-liners remained fishing and the industrial long-liners were banned, reducing the overall fishing effort (less hooks per boat/trip) over the community.

In this study, long-term changes of FIB and TL are based on a proper baseline to interpret its trajectories: previously to the development of the demersal fishery in the SMG, a scallop *Aequipecten tehuelchus* fishery prospered and collapsed (Narvarte et al., 2007). A Fishery Directorate was already functioning to gather information of landings by the time that the demersal fishery started. This allowed to describe the phases that this fishery has shown along its history, characterized by two expansion periods: the development phase of the trawl fishery (1970–1980) and the addition of the long-liners/jiggers (1996–2005; Romero, 2011). Landings of these two phases were largely dominated by the contribution of the AH. During the 1980's and due to a new pulse of scallop, most of the gears of the trawlers were modified, redirecting the effort to fishing over scallop beds (González et al., 2004; Narvarte et al., 2007; Romero, 2011). Considering that our analyses do not take into account the coastal scallop fishery pulses (which occurred a few times in the SMG history), the 1980 period is coincident with the drop of “demersal FIB” due to a significant decrease in landings of demersal fishes rather than changes in the mean trophic level of the fleets (Fig. 9). Although the disappearance/decrease of some species may be masked by the construction of functional groups that contain them (e.g. Wreckfish *Polyprion americanus*, pers. obs.) the variations of the “demersal FIB” index seem to be related to the development phases of the its fishery rather than significant changes in the structure of the demersal community.

Despite the increase in Sea Lions biomass over the last four decades due to conservation policies, it has not generated a significant increase in the predation mortality caused by this group over any group of AH. On the other hand, the increase and subsequent variations in the fishing mortality seem to be related to variations in Large hake abundance, and the decrease in Medium-sized hake abundance. Interestingly, the increasing fishing mortality in the early fishery and the decrease in the abundance of Large and Medium-sized hake have constrained the (intra- and inter-cohort) cannibalism mortality over Medium-sized hake. It has been hypothesized that cannibalism could have a strong compensatory effect over the abundance of the fishes within the same population (Smith and Reay, 1991). Our study shows that the fleets have replaced cannibalism and predation mortality by removing part of the larger cannibals and other predators (e.g. Large rays). Similarly, Juvenile hake mortality seems to be related to the abundance of its conspecific predators, but this group is expected to be more resilient due to its high abundance. Since the beginning of the fishery, Juvenile hake have increased its modelled biomass in five years, to stabilize at a higher value. Although the initial biomass of this group was calculated by Ecopath, it may also indicate that the released predation pressure over juvenile hakes is more relevant than the spawning biomass loss of larger hakes. Egg production of large hakes is more important than of medium-sized hakes, due to a higher fecundity, better nutritional quality of the eggs and an extended reproductive season (Macchi et al., 2004, 2006; Pájaro et al., 2005). Thus, an excessive increase of fishing mortality over larger hakes (and therefore “the better” spawning biomass) could lead to important negative effects over the Juvenile hake by reducing recruitment success.

Finally, the low predation mortality of AH due to SASL could be explained because SASL may have not yet reached “their carrying capacity”, and the population may continue growing in near future. A recent study on SASL skull size variation (Drago et al., 2010) in the ACS (outside the SMG) has demonstrated that somatic growth of this species has been affected by a reduction in the per capita food availability, due to a combination of the SASL population recovery and the development of industrial fishing targeting AH. Most of the changes in skull size have happened since 1990, when the SASL population peaked and the AH populations were severely reduced, leading to significant changes in the trophic relationships and the structure of the marine ecosystem (Koen Alonso and Yodzis, 2005). This may not be occurring in SMG, where the isolated stock of hake has not shown signs of overexploitation yet (Ocampo Reinaldo, 2010; Romero, 2011) and SASL abundance is still increasing (Svendsen et al., 2009; Grandi et al., 2012). Koen Alonso and Yodzis (2005) have hypothesized that Argentine hake in the ACS, in absence of SASL during 1950s, could be in larger abundances than expected when the fishery started. This scenario could be similar in the SMG before the beginning of the fishery, explaining the high abundance of AH (and probably other groups like “Small Pelagic Fish”). However, if the fleet in the SMG has nowadays replaced several predators over its food web, is possible that SASL will never reach the pristine abundance levels of the time before hunting.

5. Conclusions

This work provides the first comprehensive quantitative network model of the SMG food web related to its pelagic-demersal fishery. In spite of all the variability, this work shows that it is possible to address in the same framework externalities of different human activities like exploitation and conservation of marine resources, setting the basics for a more sustainable management and conservation of the sea. Although additional research and

further development and refinement are needed (e.g. filling of many information gaps) this approach constitutes an important basis for future ecosystem research and hypothesis testing on synergistic activities over the SMG food web. In this context, new information to build better current and past Ecopath models through the fishery history would be important to understand, compare and contrast both fishery and conservation management scenarios in an ecosystem-based approach.

Acknowledgements

The authors thank L. Storero for reviewing early versions of the manuscript, M. Maggioni for logistics of sampling and anonymous reviewers for their valuable comments. M.O.R., M.A.R., E.C. and R.A.G. are supported by CONICET (Argentina) and the work was partially supported by the projects PID 2003–371, PICT 2006–1575 (ANPCyT, Argentina) and SAC-D/Aquarius (MinCyT/CONAE, Argentina).

Appendix A. Supplementary data

Supplementary data associated with this article can be found, in the online version, at <http://dx.doi.org/10.1016/j.ecolmodel.2015.10.025>.

References

- Allen, K.R., 1971. Relation between production and biomass. *J. Fish. Res. Board Can.* 28, 1573–1581.
- Aubone, A., Bezzi, S.I., Cañete, G., Castrucci, R., Dato, C., Irusta, G., Madirolas, A., Perez, M., Renzi, M., Santos, B., Simonazzi, M., Villarino, M.F., 2004. Evaluación y sugerencias de manejo del recurso merluza (*Merluccius hubbsi*). La situación hasta 1999. In: Sánchez, R.P., Bezzi, S.I. (Eds.), *El mar Argentino y sus recursos pesqueros*, Tomo 4. INIDEP, Mar del Plata, pp. 207–235.
- Bergamino, L., Szteren, D., Lercari, D., 2012. Trophic impacts of marine mammals and seabirds in the Río de la Plata Estuary and the nearshore oceanic ecosystem. *Estuar Coast.* 35, 1571–1582.
- Christensen, V., Walters, C.J., 2004. Ecopath with ecosim: methods, capabilities and limitations. *Ecol. Model.* 172, 109–139.
- Christensen, V., Coll, M., Piroddi, C., Steenbeek, J., Buszowski, J., Pauly, D., 2014. A century of fish biomass decline in the ocean. *Mar. Ecol. Prog. Ser.* 512, 155–166.
- Christensen, V., Pauly, D., 1992. ECOPATH II—a software for balancing steady-state ecosystem models and calculating network characteristics. *Ecol. Model.* 61, 169–185.
- Christensen, V., Walters, C., Pauly, D., Forrest, R., 2008. Ecopath with ecosim version 6. In: *Lenfest Ocean Futures Project*, pp. 1–235.
- Ciancio, J.E., Pascual, M.A., Botto, F., Frere, E., Iribarne, O., 2008. Trophic relationships of exotic anadromous salmonids in the southern Patagonian Shelf as inferred from stable isotopes. *Limnol. Oceanogr.* 53, 788–798.
- Coller, N.M., 2012. *Biología, ecología y explotación de la raya platana Atlantoraja platana* (Günther, 1880). In: (Chondrichthyes, Rajidae) del Golfo San Matías. Universidad Nacional de La Plata, Argentina (Doctoral Thesis).
- Crespi-Abril, A.C., 2010. *La historia de vida de *Illex argentinus* en el golfo San Matías*. Universidad Nacional del Comahue, Argentina (Doctoral Thesis).
- Crespo, E.A., Pedraza, S.N., 1991. Estado actual y tendencia de la población de lobos marinos de un pelo (*Otaria flavescens*) en el litoral norpatagónico. *Ecol. Aust.* 2, 87–95.
- Crespo, E.A., Pedraza, S.N., Dans, S.L., Koen Alonso, M., Reyes, L.M., García, N.A., Coscarella, M., Schiavini, A.C.M., 1997. Direct and indirect effects of the high-seas fisheries on the marine mammal populations in the northern and central Patagonian Coast. *J. Northwest Atlantic Fish. Sci.* 22, 189–207.
- Cronin, M., Jessopp, M., Houle, J., Reid, D., 2014. Fishery-seal interactions in Irish waters: current perspectives and future research priorities. *Mar. Policy* 44, 120–130.
- Curtolo, L.M., Dadon, J.R., Mazzoni, H.E., 1990. Distribution and abundance of Euphausiids of Argentina in spring 1978. *Nerítica* 5, 1–14.
- Dans, S.L., Crespo, E.A., Pedraza, S.N., Koen Alonso, M., 2004. Recovery of the south american sea lion population in northern Patagonia. *Can. J. Fish. Aquat. Sci.* 61, 1681–1690.
- DeMaster, D.P., Fowler, C.W., Perry, S.L., Richlen, M.F., 2001. Predation and competition: the impact of fisheries on marine-mammal populations over the next one hundred years. *J. Mammal.* 82, 641–651.
- Di Giacomo, E.E., 1990. Contribución al estudio biológico-pesquero del pez gallo Callorhynchus callorhynchus (Linne, 1758). In: Berg, 1985, en el Golfo San Matías. Universidad Nacional de La Plata, Argentina (Doctoral Thesis).
- Di Giacomo, E., Calvo, J., Perier, M.R., Morriconi, E.R., 1993. Spawning aggregations of *Merluccius hubbsi*, in patagonian waters: evidence for a single stock? *Fish. Res.* 16, 9–16.
- Drago, M., Cardona, L., Crespo, E.A., Grandi, M.F., Aguilar, A., 2010. Reduction of skull size in South American sea lions reveals density dependent growth during population recovery. *Mar. Ecol. Prog. Ser.* 420, 253–261.
- Drago, M., Crespo, E.A., Aguilar, A., Cardona, L., García, N.A., Dans, S.L., Goodall, N., 2009. Historic change of the diet of the South American sea lion in Patagonia as revealed by isotopic analysis. *Mar. Ecol. Prog. Ser.* 384, 273–286.
- Estalles, M.L., 2013. *Características de la historia de vida y análisis de los desembarques comerciales de la raya Sympterygia bonapartii en el Golfo San Matías*. Universidad de Buenos Aires, Argentina (Doctoral Thesis).
- Gagliardini, D.A., Rivas, A.L., 2004. Environmental characteristics of San Matías gulf obtained from Landsat-TM and ETM+ data. *Gayana* 68, 186–193.
- González, R., 1998. *Biología y explotación pesquera del salmón de mar Pseudoperca semifasciata (Cuvier, 1829) (Pinguipedidae) en el Golfo San Matías*. In: Patagonia. Universidad Nacional del Sur, Argentina (Doctoral Thesis).
- González, R., Narvarte, M., Caille, G., 2007. An assessment of the sustainability of the hake *Merluccius hubbsi* artisanal fishery in San Matías Gulf, Patagonia, Argentina. *Fish. Res.* 87, 58–67.
- González, R., Narvarte, M., Morsan, E., 2004. Estado de situación de los recursos pesqueros del Golfo San Matías, sus pesquerías, especies asociadas y ambiente: informe ad hoc para la evaluación preliminar de las pesquerías marinas de Río Negro con vistas a la certificación de su sustentabilidad. In: Technical Report of the Instituto de Biología Marina y Pesquera “Almirante. Storni” No. 03/2004 (51 p.).
- González, R., Osovnikar, P., Saiz, M., 2003. Distribución y rendimiento del efectivo pesquero de merluza común *Merluccius hubbsi* y otras especies demersales a partir de los resultados de las campañas de prospección pesquera con palangre de media agua realizadas en el golfo San Matías entre los años 1996 y 1999. *IBMP Ser. Publ.* 2, 17–35.
- Grandi, M.F., Rosas de Oliveira, L., Dans, S.L., Crespo, E.A., 2012. A hunted population in recovery: effective population size for South American sea lions from Patagonia Anim. *Biology* 62, 433–450.
- Guerrero, E., Gili, J.M., Rodríguez, C., Araujo, E.M., Canepa, A., Calbet, A., González, R.A., 2013. Biodiversity and distribution patterns of planktonic cnidarians in San Matías Gulf, Patagonia, Argentina. *Mar. Ecol.* 34, 71–82.
- Gurney, L.J., Pakhomova, E.A., Christensen, V., 2014. An ecosystem model of the Prince Edward Island archipelago. *Ecol. Model.* 294, 117–136.
- Hansen, J.E., 2007. “EH-09/06”. Evaluación de anchoíta patagónica (41(–45/20′S) e investigación del Golfo San Matías en la primavera de 2006. INIDEP Technical Report 01/07 (20 pp.).
- Harkonen, T., Harding, K.C., Wilson, S., Baimukanov, M., Dmitrieva, L., Svensson, C.J., Goodman, S.J., 2012. Collapse of a marine mammal species driven by human impacts. *PLoS ONE* 7 (9), e43130, <http://dx.doi.org/10.1371/journal.pone.0043130>.
- Harwood, J., Croxall, J.P., 1988. The assessment of competition between seals and commercial fisheries in the North Sea and the Antarctic. *Mar. Mamm. Sci.* 4, 13–33.
- Isla, F.I., 2013. The flooding of the San Matías Gulf: the Northern Patagonia sea-level curve. *Geomorphology* 203, 60–65.
- Kaschner, K., Pauly, D., 2005. Competition between marine mammals and fisheries: food for thought. In: Salem, D.J., Rowan, A.N. (Eds.), *The State of the Animals III: 2005*. Humane Society Press, Washington, DC, pp. 95–117.
- Kelleher, K., 2005. Discards in the world’s marine fisheries. An update. In: *FAO Fisheries Technical Paper, No 470*. Food and Agriculture Organization of the United Nations (FAO), Rome (131 pp.).
- Koeller, P.A., Coates-Markle, L., Neilson, J.D., 1989. Feeding ecology of juvenile (age-0) silver hake (*Merluccius bilinearis*) on the Scotian Shelf. *Can. J. Fish. Aquat. Sci.* 46, 1762–1768.
- Koen Alonso, M., Yodzis, P., 2005. Multispecies modelling of some components of the marine community of northern and central Patagonia, Argentina. *Can. J. Fish. Aquat. Sci.* 62, 1490–1512.
- Macchi, C.J., Pájaro, M., Ehrlich, M., 2004. Seasonal egg production pattern of the Patagonian stock of Argentine hake (*Merluccius hubbsi*). *Fish. Res.* 67, 25–38.
- Macchi, G.J., Pájaro, M., Militelli, M., Radovani, N., Rivas, L., 2006. Influence of size, age and maternal condition on the oocyte dry weight of Argentine hake (*Merluccius hubbsi*). *Fish. Res.* 80, 345–349.
- Machado Schiaffino, G., Juanes, F., García-Vázquez, E., 2011. Identifying unique populations in long-dispersal marine species: Gulfs as priority conservation areas. *Biol. Conserv.* 144, 330–338.
- Macpherson, E., Gordo, A., 1994. Effect of prey densities on cannibalism in Cape hake (*Merluccius capensis*) off Namibia. *Mar. Biol.* 119, 145–149.
- Millán, D., 2009. *Anuario de Estadísticas Pesqueras de la Provincia de Río Negro*. Departamento Policía de Pesca, Dirección de Pesca, Río Negro, Argentina.
- Morales-Zárate, M.V., Arreguín-Sánchez, F., López-Martínez, J., Lluich-Cota, S.E., 2004. Ecosystem trophic structure and energy flux in the Northern Gulf of California, México. *Ecol. Model.* 174, 331–345.
- Morissette, L., 2007. Complexity, cost and quality of ecosystem models and their impact on resilience: a comparative analysis, with emphasis on marine mammals and the Gulf of St. Lawrence. University of British Columbia, Canada (Ph.D. Thesis).
- Muto, E.Y., Soares, L.S.H., 2011. Spatio-temporal variations in the diet and stable isotope composition of the Argentine hake *Merluccius hubbsi* Marini, 1933 of the continental shelf of southeastern Brazil. *Mar. Biol.* 158, 1619–1630.
- Narvarte, M., González, R., Filippo, P., 2007. Artisanal mollusk fisheries in San Matías Gulf (Patagonia Argentina): an appraisal of the factors contributing to unsustainability. *Fish. Res.* 87, 68–76.

- Ocampo Reinaldo, M., 2010. Evaluación pesquera integral de la merluza común (*Merluccius hubbsi* Marini, 1933) del Golfo San Matías y efectos de la explotación de esta especie sobre otros componentes de la trama trófica. Universidad Nacional de Córdoba, Argentina (Doctoral Thesis).
- Ocampo Reinaldo, M., González, R., Williams, G., Storero, L., Romero, M.A., Narvarte, M., Gagliardini, D.A., 2013. Spatial patterns of the Argentine hake *Merluccius hubbsi* and oceanographic processes in a semi-enclosed Patagonian ecosystem. *Mar. Biol. Res.* 9, 394–406.
- Ocampo-Reinaldo, M., González, R.A.C., Romero, M.A., 2011. Feeding strategy and cannibalism of the Argentine hake *Merluccius hubbsi* Marini 1933. *J. Fish Biol.* 79, 1795–1814.
- Odum, E.P., 1969. The strategy of ecosystem development. *Science* 104, 262–270.
- Odum, E.P., 1971. *Fundamentals of Ecology*. Saunders College Publishers, Philadelphia, PA.
- Pájaro, M., Macchi, G.J., Martos, P., 2005. Reproductive pattern of the patagonian stock of Argentine hake (*Merluccius hubbsi*). *Fish. Res.* 72, 97–108.
- Palomares, M.L.D., Pauly, D., 1998. Predicting food consumption of fish populations as functions of mortality food type, morphometrics, temperature and salinity. *Mar. Freshwater Res.* 49, 447–453.
- Pauly, D., Christensen, V., Dalsgaard, J.P.T., Froese, R., Torres, F., 1998. Fishing down the marine food webs. *Science* 279, 860–863.
- Pauly, D., Christensen, V., Walters, C., 2000. Ecopath, Ecosim, and Ecospace as tools for evaluating ecosystem impact of fisheries. *ICES J. Mar. Sci.* 57, 697–706.
- Piola, A.R., Scasso, L.M., 1988. Circulación en el Golfo San Matías. *Geoacta* 15, 33–51.
- Plagányi, É.E., Butterworth, D.S., 2002. Competition with fisheries. In: Perrin, W.F., Würsig, B., Theewissen, J.G.M. (Eds.), *Encyclopedia of Marine Mammals*. Academic Press, Oxford, pp. 268–273.
- Prenski, L.B., Angelescu, V., 1993. Ecología trófica de la merluza común (*Merluccius hubbsi*) del Mar Argentino. Parte 3. Consumo anual de alimento a nivel poblacional y su relación con la explotación de las pesquerías multiespecíficas. In: INIDEP Documento Científico 1. INIDEP, Mar del Plata.
- Read, A.J., 2008. The looming crisis: interactions between marine mammals and fisheries. *J. Mammal.* 89, 541–548.
- Rochet, M.-J., Trenkel, V.M., 2005. Factors for the variability of discards: assumptions and field evidence. *Can. J. Fish. Aquat. Sci.* 62, 224–235.
- Rojo, A.L., Silvoza, J.M., 1969. Estudio biológico de la merluza (*Merluccius merluccius hubbsi*) del sector patagónico. In: Campaña exploratoria SUR-I. Patagonia. Sección 152 Biológica. Serie Informes Técnicos. Publicación 18. Proyecto de Desarrollo Pesquero. FAO.
- Rojo, A.L., Silvoza, J.M., 1970. La merluza de los golfos San Matías. In: Nuevo y de la plataforma adyacente. Campaña merluza 70-I. Serie Informes Técnicos. Publicación 24. Proyecto de Desarrollo Pesquero. FAO.
- Romero, M.A., 2011. Rol de los mamíferos marinos en el contexto de la trama trófica del ecosistema del Golfo San Matías e interacciones con la pesquería de especies demersales. Universidad Nacional del Comahue, Argentina (Doctoral Thesis).
- Romero, M.A., Dans, S., González, R., Svendsen, G., García, N., Crespo, E., 2011. Solapamiento trófico entre el lobo marino de un pelo *Otaria flavescens* y la pesquería de arrastre demersal del golfo San Matías, Patagonia, Argentina. *Lat. Am. J. Aquat. Res.* 39, 344–358.
- Romero, M.A., Dans, S.L., García, N.A., Svendsen, G.M., González, R., Crespo, E.A., 2012. Feeding habits of two sympatric dolphin species off North Patagonia, Argentina. *Mar. Mamm. Sci.* 28, 364–377.
- Romero, M.A., González, R., Ocampo Reinaldo, M., 2010. When conventional fisheries management measures are not effective to reduce the catch and discard of juvenile fish: a case study of Argentine hake trawl fishery in San Matías Gulf (Patagonia, Argentina). *N. Am. J. Fish. Manage.* 30, 702–712.
- Romero, M.A., Ocampo Reinaldo, M., Williams, G.N., Narvarte, M.A., Gagliardini, D.A., González, R., 2013. Understanding the dynamics of an enclosed trawl demersal fishery in Patagonia (Argentina): a holistic approach combining multiple data sources. *Fish. Res.* 140, 73–82.
- Ruiz, A.E., Fondacaro, R., 1997. Diet of hake (*Merluccius hubbsi* Marini) in a spawning and nursery area within Patagonian shelf waters. *Fish. Res.* 30, 157–160.
- Sardella, N., Timi, J., 2004. Parasites of Argentine hake in the Argentine Sea: population and infracommunity structure as evidence for host stock discrimination. *J. Fish. Biol.* 65, 1472–1488.
- Scasso, L., Piola, A., 1988. Intercambio neto de agua entre el mar y la atmósfera en el golfo San Matías. *Geoacta* 15, 13–31.
- Smith, C., Reay, P., 1991. Cannibalism in teleost fish. *Rev. Fish Biol. Fish.* 1, 41–64.
- Svendsen, G.M., Dans, S.L., González, R., Williams, G., Romero, M.A., Gagliardini, D.A., Crespo, E.A., 2013. Occurrence of South American fur seals *Arctocephalus australis* (Zimmermann 1783) in San Matías Gulf, Patagonia, Argentina. *Lat. Am. J. Aquat. Res.* 41, 576–583.
- Svendsen, G.M., Romero, M.A., Borella, F., Inostroza, J.C., González, R.A., 2009. Informe del relevamiento de los apostaderos de lobos marinos de un pelo. In: *Otaria flavescens*, de la provincia de Río Negro durante enero de 2009. Technical Report of the Instituto de Biología Marina y Pesquera “Almirante Storni” No. 01/2009 (8 pp.).
- Trites, A.W., Christensen, V., Pauly, D., 1997. Competition between fisheries and marine mammals for prey and primary production in the Pacific Ocean. *J. Northw. Atl. Fish. Sci.* 22, 173–187.
- Ulanowicz, R.E., 1986. *Growth and Development: Ecosystems Phenomenology*. Springer-Verlag Press, New York, NY.
- Ulanowicz, R.E., Norden, J.S., 1990. Symmetrical overhead in flow networks. *Int. J. Syst. Sci.* 21, 429–437.
- Ulanowicz, R.E., Puccia, C.J., 1990. Mixed trophic impacts in ecosystems. *Coenoses* 5, 7–16.
- Vaz-dos-Santos, A.M., Rossi-Wongtschowski, C.L.D.B., de Figueiredo, J.L., Ávila-da-Silva, A.O., 2010. Threatened fish of the world: *Merluccius hubbsi* Marini, 1933 (Merlucciidae). *Environ. Biol. Fishes* 87, 349–350.
- Walters, C., Christensen, V., Pauly, D., 1997. Structuring dynamic models of exploited ecosystems from trophic mass-balance assessments. *Rev. Fish Biol. Fish.* 7, 139–172.
- Williams, G., Sapoznik, M., Ocampo Reinaldo, M., Solis, M., Narvarte, M., Gonzalez, R., Esteves, J.L., Gagliardini, D., 2010. TM/ETM, AVHRR and SeaWiFS sensor studies in San Matías Gulf (Patagonia, Argentina): relationship with fishing activity and oceanographic surveys data. *Int. J. Remote Sens.* 31, 4531–4542.
- Yodzis, P., 1998. Local trophodynamics and the interaction of marine mammals and fisheries in the Benguela ecosystem. *J. Anim. Ecol.* 67, 635–658.
- Zhang, Y., Chen, Y., 2007. Modeling and evaluating ecosystem in 1980s and 1990s for American lobster (*Homarus americanus*) in the Gulf of Maine. *Ecol. Model.* 203, 475–489.