

Effect of particle size, polydispersity and polymer degradation on progesterone release from PLGA microparticles: Experimental and mathematical modeling



Carlos Busatto, Juan Pesoa, Ignacio Helbling, Julio Luna, Diana Estenoz*

Instituto de Desarrollo Tecnológico para la Industria Química, INTEC (Universidad Nacional del Litoral and CONICET), Güemes 3450, Santa Fe, 3000, Argentina

ARTICLE INFO

Keywords:

Poly(lactic-co-glycolic acid)
Microparticles
Progesterone
Drug delivery
Mathematical modeling

ABSTRACT

Poly(lactic-co-glycolic acid) (PLGA) microparticles containing progesterone were prepared by the solvent extraction/evaporation and microfluidic techniques. Microparticles were characterized by their size distribution, encapsulation efficiency, morphology and thermal properties. The effect of particle size, polydispersity and polymer degradation on the *in vitro* release of the hormone was studied. A triphasic release profile was observed for larger microparticles, while smaller microspheres showed a biphasic release profile. This behavior is related to the fact that complete drug release was achieved in a few days for smaller microparticles, during which polymer degradation effects are still negligible. A mathematical model was developed that predicts the progesterone release profiles from different-sized PLGA microspheres. The model takes into account both the dissolution and diffusion of the drug in the polymeric matrix as well as the autocatalytic effect of polymer degradation. The model was adjusted and validated with novel experimental data. Simulation results are in very good agreement with experimental results.

1. Introduction

Progesterone is a lipophilic steroid hormone with low molecular weight. Several progesterone delivery systems have been proposed for hormone replacement therapies in women (Nath and Sitruk-Ware, 2009). In addition, progesterone contained into biodegradable and non-biodegradable polymeric matrices has been used for regulating the estrous cycle of production animals (Rathbone, 2012; Weibel et al., 2014; Jameel et al., 1998).

Poly(lactic-co-glycolic acid) (PLGA) has been widely studied as biomaterial for drug delivery applications (Han et al., 2016; Guo et al., 2015). Drug delivery systems offer several advantages, such as appropriate control of release kinetics, reduction of drug concentration variability in blood which may cause adverse effects, decrease of dosage times and improvement of patient compliance, among others (Hines and Kaplan, 2013). PLGA microspheres are preferred for this purpose because of their biodegradability in aqueous environments such as living tissues, and their safe degradation products (Garner et al., 2015). Also, the degradation rate of PLGA can be adjusted by modifying several properties, such as polymer composition (Ji et al., 2016), molecular weight (Su et al., 2009) and nature of terminal groups (Cai et al., 2009).

Several phenomena are related to drug release kinetics from PLGA

microspheres, including diffusive transport of the drug through the polymer matrix, polymer degradation by autocatalytic hydrolysis and polymer erosion (Fredenberg et al., 2011). Understanding the transport mechanisms and the physico-chemical processes that influence the release rate is key in order to design controlled drug delivery systems. There are other factors that contribute to drug release kinetics from PLGA microparticles, such as particle size (Chen et al., 2017; Fu et al., 2005), initial porosity of the particles (Wang et al., 2015; Klose et al., 2006) and drug distribution within the polymer matrix (Cai et al., 2009).

Drug release profiles from biodegradable microparticles are biphasic (Guo et al., 2015; Tanetsugu et al., 2017) or triphasic (Berchane et al., 2007; Raman et al., 2005) on the basis of the dynamics of the processes involved: “burst” effect, diffusion through the polymer matrix and fluid-filled pores, and degradation/erosion of the polymer (Regnier-Delplace et al., 2013). Since PLGA matrix is mainly dense and hydrophobic, diffusion through the polymer matrix is limited to small hydrophobic molecules. Transport through aqueous pores is the principal transport mechanism for highly hydrophilic and macromolecular drugs, such as proteins and peptides (Fredenberg et al., 2011). The initial phase of the release process is often characterized by the “burst” effect, where a significant fraction of the drug is rapidly released. This

* Corresponding author.

E-mail address: destenoz@santafe-conicet.gov.ar (D. Estenoz).

effect is related to the drug encapsulated near the surface of the microspheres (Allison, 2008) and the large initial concentration gradient. The subsequent release phase is controlled by the diffusion through the polymeric matrix and water-filled pores, according to the drug transport properties. In addition, a final phase could be observed depending on the degradation dynamics of the polymer, where accelerated release takes place due to the presence of large pores as a result of polymer degradation, but it can be also attributed to substantial microparticle swelling (Gasmi et al., 2016), the presence of cracks or particle deintegration (Thakur and Thakur, 2015).

In drug formulation, the control over release kinetics is key to achieve an optimum pharmacokinetic effect. The polydispersity in size and morphology of the particles obtained from the conventional preparation methods (homogenization, mechanical agitation and sonication) can produce undesirable variations in the rate of particle degradation, drug stability and release kinetics (Leon et al., 2015; Sansdrap and Moës, 1997). As an alternative, microfluidics allows the production of highly monodisperse particles with controlled morphology (Duncanson et al., 2012). It offers a significantly greater control over the kinetics of drug release by minimizing the phenomenon of burst release, which is commonly observed with polydisperse particles (Xu et al., 2009).

Several mathematical models have been developed to predict the release of drugs from PLGA microparticles using the analytical solution of Fick's second law of diffusion (Ford Versypt et al., 2013). A typical approach is the correlation of the drug effective diffusivity with the evolution of the polymer average molecular weight based on an empirical equation to fit the degradation data (Faisant et al., 2002; Raman et al., 2005; Berchane et al., 2007). Siepmann et al. (2005) proposed an empirical method for drug release considering that each microspheres size has a different and constant effective diffusivity. They concluded that the strong dependence of drug mobility within the polymeric matrix on the microsphere size demonstrates the importance of autocatalysis in this type of drug delivery system. Siepmann et al. (2002) developed a model for drug release from PLGA microparticles using Monte Carlo simulations. The model considers the drug dissolution, the diffusion with non-constant diffusivities and the evolution of particle porosity. The effective diffusivity of the drug was defined as a product of a critical diffusion coefficient and the porosity. Ford et al. (2011) proposed a mathematical model of reaction-diffusion for the release of drugs from PLGA microspheres considering the autocatalytic degradation of the polymeric matrix and the evolution of the porous structure. The release profiles for constant diffusivity collapsed onto a single curve while those for diffusion with variable effective diffusivity showed a dependence with the particle size. Casalini et al. (2014) presented a mathematical model capable of predicting polymer degradation and drug release from PLGA microparticles. The model consists of a system of partial differential equations solved by the method of lines. The polymer degradation modeling takes into account the autocatalytic effect due to the acid environment within the device and the drug release modeling considers both dissolution of the drug and diffusion of the dissolved drug through the polymeric matrix. An effective diffusion coefficient that increases with the hydrolysis of the polymer was used.

In our previous work, a mathematical model to describe the heterogeneous hydrolytic degradation of PLGA microspheres was developed (Busatto et al., 2017). It was based on a detailed kinetic mechanism that considers the autocatalytic degradation of the different types of ester bonds in the copolymer by random chain scission. The model was able to estimate the evolutions of average molecular weights, molecular weight distributions, and mass loss of microparticles during degradation. In addition, it was used to predict the morphological changes of different-sized microparticles during degradation and to study the effect of particle size and molecular weight on the degradation behavior of microparticles.

In this work, the encapsulation and controlled release of

progesterone from PLGA microspheres is experimentally and theoretically studied. The microparticles were prepared by the solvent extraction/evaporation and microfluidic techniques. Particle size distribution and morphology were measured by optical microscopy, encapsulation efficiency by High Performance Liquid Chromatography (HPLC) and thermal properties by Differential Scanning Calorimetry (DSC). The effect of particle size, polydispersity and polymer degradation on the *in vitro* release of the hormone in phosphate buffer at 37 °C was studied. In addition, our previous model for the heterogeneous hydrolytic degradation of PLGA microspheres was extended in order to incorporate the drug transport, the intraparticle drug dissolution and the drug dissolution at the particle surface. The model predicts the progesterone release and takes into account the effects of polymer degradation and system characteristics (particle size, polymer molecular weight, drug load) on the drug release rate.

2. Materials and methods

2.1. Materials

PLGA 50:50, weight-average molecular weight (M_w): 6622 Da (Shanghai Easier Industrial Development Co. Ltd., Shanghai, China), progesterone (99.2%, Farmabase), HPLC-grade methanol (Sintorgan), methylene chloride (Cicarelli), polyvinyl alcohol (PVA) (205 kDa, 87.7% hydrolyzed, Sigma Aldrich), sodium hydrogen phosphate (Na_2HPO_4) (Anedra), potassium dihydrogen phosphate (KH_2PO_4) (Anedra), Tween 80 (Anedra), sodium chloride (Cicarelli) and potassium chloride (Cicarelli) were used as received. Distilled and deionized water was used to prepare all the solutions.

2.2. Preparation of microparticles by the solvent extraction/evaporation technique

PLGA (450 mg) and progesterone (20, 30 and 40% w/w) were co-dissolved in 3 mL of methylene chloride. The solution was slowly dropped onto the aqueous phase (17 mL of 2% w/v PVA solution) under continuous stirring by a homogenizer (Ultra-Turrax T25D, IKA), and the resulting emulsion was stirred for 5 min. Afterwards, 70 mL of 0.3% PVA solution was added to the emulsion and stirring was continued for an additional 15 or 30 min. The remaining solvent in the microspheres was evaporated under vacuum on a rotary evaporator for 3 h. The solid microparticles were washed three times with deionized water and collected by centrifugation or sedimentation according to the particle size. Finally, the microspheres were lyophilized and stored at $-20\text{ }^\circ\text{C}$ until further analysis. Three batches of microspheres were prepared using different conditions (see Table 1) to produce microspheres with different particle sizes.

2.3. Preparation of microparticles by microfluidics

A co-flow microfluidic device was used for the preparation of the microparticles (Experiment D). As shown in Fig. 1, the system consisted of two concentric capillary tubes (called tube 1 and tube 2) and a T-junction. The fused silica tube 1 (inner diameter: 75 μm , outer diameter: 148 μm) associated with adjusted tubing sleeves (1/16", inner diameter of 180 μm) was inserted into the T-junction (1/16") along its main axis. This tube crosses the T-joint and ends in the center of the fused silica tube 2 (inner diameter: 250 μm , outer diameter: 356 μm). The T-junction allows the injection of the dispersed liquid phase into the continuous phase.

The continuous phase consisted of a PVA solution (1% w/v) and the dispersed phase was prepared by dissolving 100 mg of PLGA and progesterone (20% w/w) in 2.5 mL of methylene chloride. The dispersed and continuous phases were injected into the device using syringe pumps and the flow rates were 450 $\mu\text{L min}^{-1}$ and 1020 $\mu\text{L min}^{-1}$, respectively. The resulting emulsion was collected for 30 min in a beaker

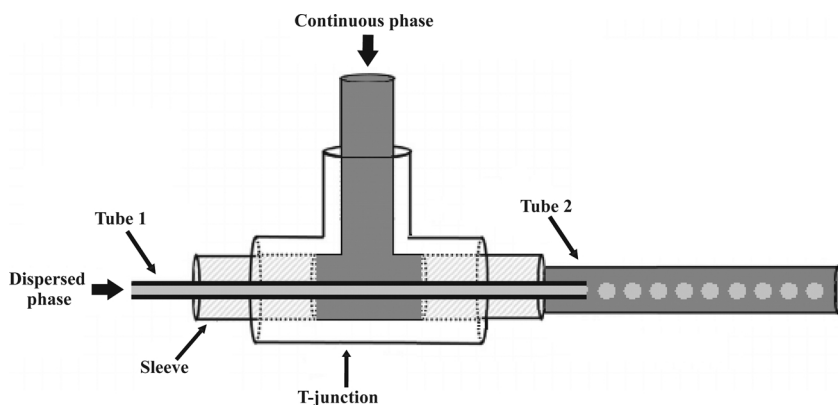

Fig. 1. Microfluidic device used for the preparation of the micro-particles.

containing 100 mL of ultrapure water. The collected particles were immediately placed under stirring, using a mechanical stirrer at 200 rpm for 1 h in order to extract the remaining solvent in the microparticles. The particles were then separated by sedimentation and washed twice with ultrapure water. Finally, microparticles were lyophilized and stored for further analysis.

2.4. Particle size and size distribution

The microparticles were resuspended in distilled water and observed under an optical microscope (DM2500 M, Leica) coupled with a camera (DM 2500M DFC290 HD, Leica). The mean size of microparticles and the particle size distributions were determined by analyzing the images with an image processing software. Approximately 300 particles per sample were measured to determine the mean diameter.

2.5. Thermal characterization

Thermal properties of progesterone, PLGA and progesterone-loaded microparticles were investigated using a differential scanning calorimeter (DSC Q2000, TA Instrument). The samples (3–5 mg) were placed in aluminum pans, sealed and heated at a rate of $10\text{ }^{\circ}\text{C min}^{-1}$ under an inert atmosphere of nitrogen at a flow rate of 50 mL min^{-1} . The heat flow was recorded in a temperature range of 0–160 $^{\circ}\text{C}$. The samples were cooled using a cooling system (RSC90, TA instruments) and heated again under the same conditions.

2.6. Drug loading

10 mg of microparticles were placed in 50 mL of ethanol for 24 h. Drug quantification was performed by HPLC using a Prominence LC20A Shimadzu Chromatograph equipped with a ZORBAX[®] Eclipse XDB-C18 column (5 μm particle size, $250 \times 4.6\text{ mm}$) and a diode array detector. The mobile phase consisted of a methanol/water mixture (95:5 v/v) at a flow rate of 1.0 mL min^{-1} . The column temperature and the detection wavelength were 30 $^{\circ}\text{C}$ and 254 nm, respectively.

2.7. In vitro release assays

20 mg of microparticles loaded with progesterone were dispersed in 200 mL of phosphate buffer (pH 7.4) containing Tween 80 (1% w/v). The vials were incubated at 37 $^{\circ}\text{C}$ under orbital stirring (50 rpm). At different times, 4 mL of samples were taken and replaced with an equal volume of fresh medium. The samples were quantified by HPLC.

2.8. Mathematical model of drug release

A mathematical model was developed to predict the controlled release of progesterone from PLGA microspheres. The model considers

the drug diffusion and dissolution as well as the effect of the polymer degradation on the release rate from different sized-microspheres. The model consists of the following two modules.

2.8.1. Degradation module

It is based on our previous model of heterogeneous hydrolytic degradation of PLGA microparticles (Busatto et al., 2017). The module assumes the following hypotheses: (i) hydrolysis kinetic constants are independent of chain length; (ii) the different types of ester bonds are uniformly distributed within the polymer chain; (iii) all particles have the same size (equal to their mean diameter) and are modeled as a sphere of constant volume; (iv) the polymeric matrix is amorphous; (v) oligomers species with a chain length up to the critical chain length can be dissolved; (vi) the volume of degradation medium largely exceeds microparticles volume; (vii) the generation rate of acid catalyst (H^+) within microparticles is higher than the diffusion rate. The system of equations that allows solving the Degradation Module is described in the Appendix A. This module allows estimating the evolutions of average molecular weights and mass loss of microparticles during degradation.

2.8.2. Release module

This module describes the drug transport. It assumes the following hypotheses: i) progesterone stability is not affected by the pH within the polymeric matrix; ii) the initial progesterone load that exceeds its solubility in the polymeric matrix is present as an amorphous phase uniformly distributed in the polymeric matrix; iii) progesterone load does not affect the degradation rate of the polymeric matrix; (iv) progesterone solubility in the polymeric matrix is not affected during degradation; (v) all particles have the same size (equal to their mean diameter) and are modelled as a constant volume sphere. The Release Module is based on the following system that allows describing the release process considering that the main mechanism of mass transfer is the diffusion of the drug through the polymeric matrix:

$$\frac{\partial C_{PG}}{\partial t} = \frac{1}{r^2} \frac{\partial}{\partial r} \left(r^2 D_{PG} \frac{\partial C_{PG}}{\partial r} \right) + S \quad t < t^* \quad (1)$$

where C_{PG} is the concentration of progesterone dissolved in the polymeric matrix, D_{PG} is the effective diffusion coefficient of the hormone in the polymeric matrix and S is the source term represented by Casalini et al. (2014):

$$S = \frac{\partial C_{PGa}}{\partial t} = k'_a \frac{a_m}{V_p} (C_{PGm} - C_{PG}) = k_a (C_{PGm} - C_{PG}) \quad (2)$$

where C_{PGa} is the concentration of progesterone in the amorphous phase dispersed in the polymeric matrix, C_{PGm} is the maximum solubility of progesterone in the polymeric matrix, k'_a is a mass transfer coefficient of progesterone related to the amorphous phase inside the polymeric matrix, a_m is the area of the amorphous phase and V_p is the particle volume.

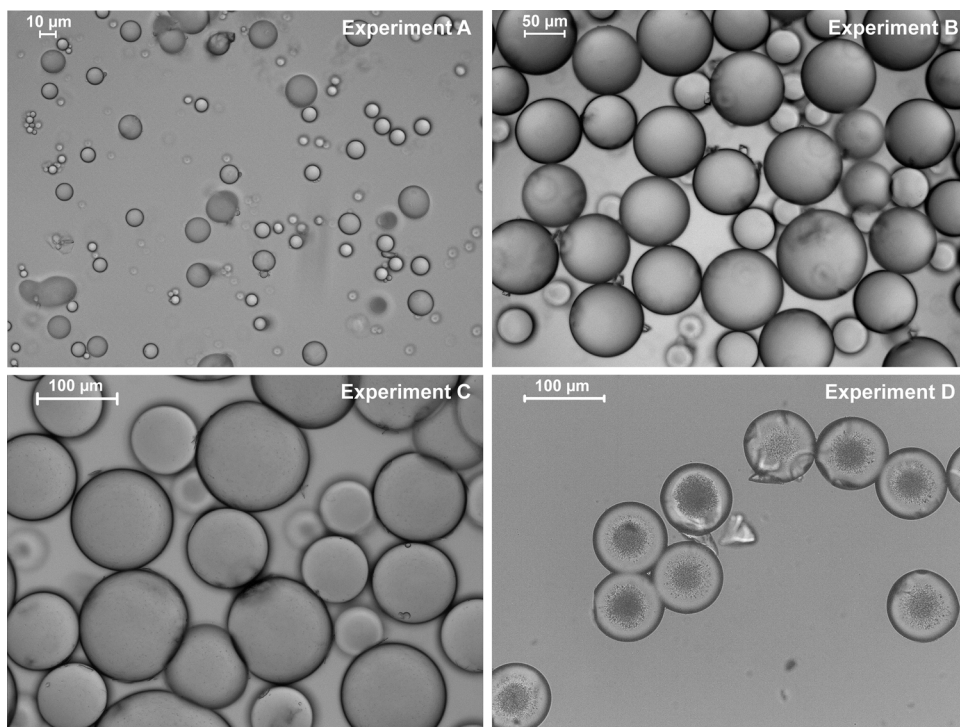

Fig. 2. Optical images of progesterone-loaded PLGA microspheres.

Note that as degradation proceeds, the morphological changes can modify the transport mechanism. Thus, a time (named t^*) can exist at which the mass transfer in the polymeric phase is not the preferential transport mechanism in the release process.

Initial conditions of C_{PG} and C_{PGa} are determined by the C_{PGm} and the effective drug loading (C_{PGeff}), considering a uniform dispersion of the drug within the polymeric matrix:

$$\begin{aligned} C_{PG} &= C_{PGm} \\ C_{PGa} &= C_{PGeff} - C_{PGm} \quad t = 0, 0 \leq r \leq R \end{aligned} \quad (3)$$

Concerning the boundary conditions, the symmetry condition for the concentration of progesterone is applied in the center of the microparticle and the resistance to mass transfer is considered at the microparticle-aqueous medium interface:

$$\left. \frac{\partial C_{PG}}{\partial r} \right|_{r=0} = 0 \quad (4)$$

$$D_{PG}(r=R) \left. \frac{\partial C_{PG}}{\partial r} \right|_{r=R} = k_{PG}(C_{PGb} - C_{PG}(r=R)) = -k_{PG} C_{PG}(r=R) \quad (5)$$

where C_{PGb} is the concentration of progesterone in the release medium and k_{PG} is the mass transfer coefficient of progesterone related to the surface of the particles and the release medium. The value of C_{PGb} is considered negligible because the volume of the release medium is large enough compared to the released drug.

The transport parameter k_{PG} can be calculated from the Sherwood number (Sh), which equals 2 for spherical systems under stagnant conditions (Casalini et al., 2014):

$$Sh = 2 = \frac{k_{PG} 2R}{D_{PGb}} \quad (6)$$

where D_{PGb} is the diffusion coefficient of progesterone in the release medium and R is the radius of the particle.

The increase of the drug effective diffusivity as a consequence of polymer matrix degradation is related to the evolution of the weight-average molecular weight of the polymer through the following expression (Ford et al., 2011):

$$D_{PG} = D_{PG}^0 \left[1 + \left(1 - \frac{\bar{M}_w(t)}{\bar{M}_w(t=0)} \right) (k_D - 1) \right] \quad (7)$$

where D_{PG}^0 is the initial effective diffusivity of progesterone, \bar{M}_w is the weight-average molecular weight of the polymer (obtained by the Degradation Module) and k_D is an adjustment parameter related to the effective diffusivities of the polymeric species in aqueous solution and in the solid.

After the critical time, the system is described through a macroscopic mass balance in the particle that considers the mass transport in the fluid phase, as follows:

$$\begin{aligned} \frac{d \langle C_{PG} \rangle}{dt} &= -k'_d \frac{a_p}{V_p} \left(\langle C_{PG} \rangle - C_{PGb} \right) = -k_d \left(\langle C_{PG} \rangle - C_{PGb} \right) \\ &= -k_d \langle C_{PG} \rangle \quad t > t^* \end{aligned} \quad (8)$$

where $\langle C_{PG} \rangle$ is the volume-average concentration of progesterone inside the particles, k'_d is a mass transfer coefficient of progesterone related to the particle surface and the release medium, a_p is the particle area and V_p is the particle volume.

2.8.3. Model implementation

The mathematical models were implemented in Matlab. The Degradation Module is based on Eqs. (A.1)–(A.12) of Appendix A. It consists of a set of partial differential equations solved using a finite difference scheme to discretize the radial dimension and a Forward Euler method for time discretization. The typical computing time in an Intel Core 2 Duo processor ranged from 1 to 3 min per simulation. Note that the Degradation Module can be solved independently of the Release Module.

The Release Module consists of Eqs. (1)–(8) and it was solved using a second order finite difference scheme to discretize the radial dimension and a Crank-Nicolson method for the temporal discretization. Fitting optimization was carried out by square errors minimization. The typical computing time in an Intel® Core 2 Duo processor ranged from 1 to 2 min per simulation. This module requires the output data of the Degradation Module (Eq. (7)).

Table 1
Experimental conditions and characteristics of PLGA microparticles.

Experiment	Solvent extraction/evaporation technique			Microfluidics
	A	B	C	D
Stirring rate (rpm)	3000	500	500	–
Stirring time (min)	30	30	15	–
D_p (μm)	9.3 ± 4.4	71.6 ± 19.3	131.3 ± 45.8	87.9 ± 3.6
Coefficient of variation (%)	47.3	26.9	34.9	4.1
Theoretical drug loading (% w/w)	20	20	20	20
Encapsulation Efficiency (%)	78.2	86.3	78.9	70.7

3. Results and discussion

Optical images of progesterone-loaded PLGA microparticles prepared by the solvent extraction/evaporation technique and by microfluidics are shown in Fig. 2. As it can be seen, they were spherical with smooth surface. Microspheres having different sizes were obtained by modifying the rate and time of homogenization during their preparation by the solvent extraction/evaporation technique. The experimental conditions, average particle diameters (D_p) and drug encapsulation efficiencies are shown in Table 1.

The particle size distributions for both preparation methods are shown in Fig. 3. Microspheres prepared by the solvent extraction/evaporation technique present a wider size distribution as microparticle dimension is increased. In contrast, microspheres prepared by microfluidics have a narrow size distribution compared to those obtained by the conventional method for similar mean particle diameters. Also, the coefficient of variation indicates the relative narrow size distribution of the particles prepared by microfluidics. Both techniques showed similar drug encapsulation efficiencies, however, slightly higher encapsulation efficiencies were observed for the solvent evaporation/extraction technique.

DSC studies of PLGA, progesterone and progesterone-loaded PLGA microparticles were performed (Fig. 4). Thermogram of pure progesterone has a sharp endothermic peak at 129 °C, which corresponds to its melting point. For microspheres with a theoretical drug loading of 20% w/w the fusion peak corresponding to progesterone was not observed, indicating that the hormone is in an amorphous state inside the

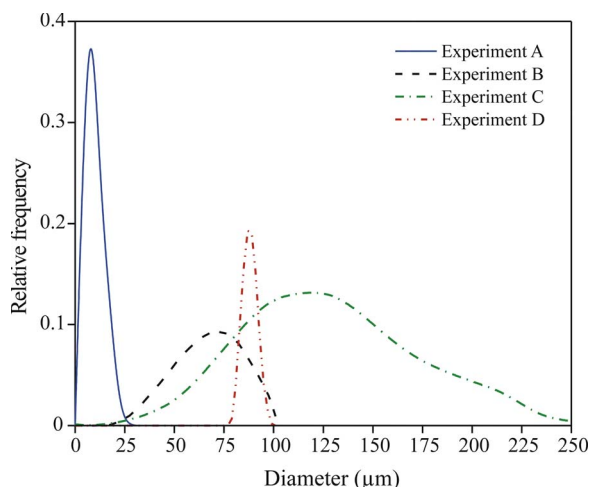

Fig. 3. Particle size distributions of progesterone-loaded PLGA microspheres.

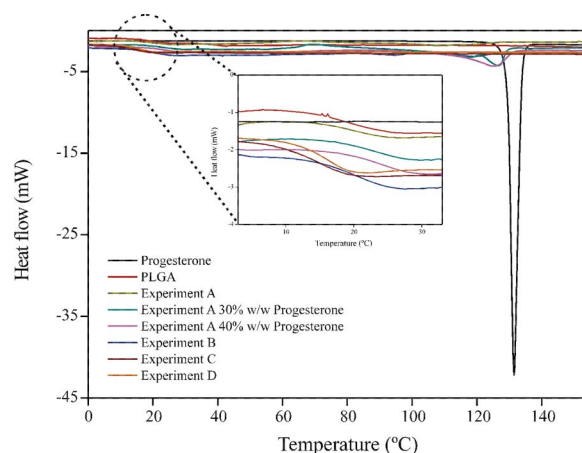

Fig. 4. DSC thermograms of PLGA, progesterone and progesterone-loaded PLGA microparticles.

polymeric matrix. Thermograms of microparticles with a theoretical drug loading of 30% and 40% w/w present a fusion peak corresponding to progesterone, indicating that high drug loadings lead to crystals formation inside the particles. In addition, it can be seen that the T_g of the PLGA is around 20 °C.

Figs. 5 and 6a–b show the results of the *in vitro* release studies of progesterone from PLGA microspheres of different particle sizes. The particle dimension significantly affects the release profile and the rate of drug release. It can be noted the increase of the release rate for smaller particles as a consequence of shorter diffusion paths (the surface/volume ratio is higher for smaller microspheres).

Microspheres with larger diameters (Experiments C and D) present a triphasic release profile due to polymer degradation effects (Fig. 5a–b). Initially, a high release rate of the hormone is observed (“burst” effect), since part of the drug is trapped on the surface of the polymeric matrix during the preparation process. Thereafter, a second release phase takes place, where drug release is controlled by the diffusion of the hormone through the polymeric matrix. Finally, a rapid increase in the drug release rate is observed. This final release phase is due to degradation of the polymer. As polymer degrades, the molecular weight decreases and the particle become more porous due to erosion, which causes a rapid increase in the effective diffusion coefficient of the drug through the polymeric matrix. This results in an increased release rate of the drug at the so-called critical time (t^*), at which drug diffusion through the polymeric matrix is not the preferential transport mechanism in the release process. This release phase involves morphological changes related to the porous structure of the particles, causing a rapid release of the remaining encapsulated drug. The critical time values for microspheres of Experiments C and D were approximately 21 and 32 days, respectively. This result is due to the effect of autocatalysis that is more important with the increase of particle size.

Microparticles obtained in Experiment D by microfluidics showed a release profile with a high reproducibility compared to the microparticles prepared by the conventional solvent evaporation/extraction technique. In addition, they presented a lower initial release compared to those obtained by the conventional method for similar mean particle diameters. This behavior is related to the fact that microfluidic particles have a narrow size distribution and controlled morphology. Polydispersity in sizes is one of the main causes of the initial drug release due to the presence of small microspheres that encapsulate a significant fraction of drug that is released more rapidly (Berchane et al., 2007).

As it can be observed in Fig. 6a–b, microparticles of Experiments A and B presented a biphasic release profile. Initially, a high release rate was observed due to the “burst” effect, followed by a second phase where drug release is controlled by its diffusion through the polymeric

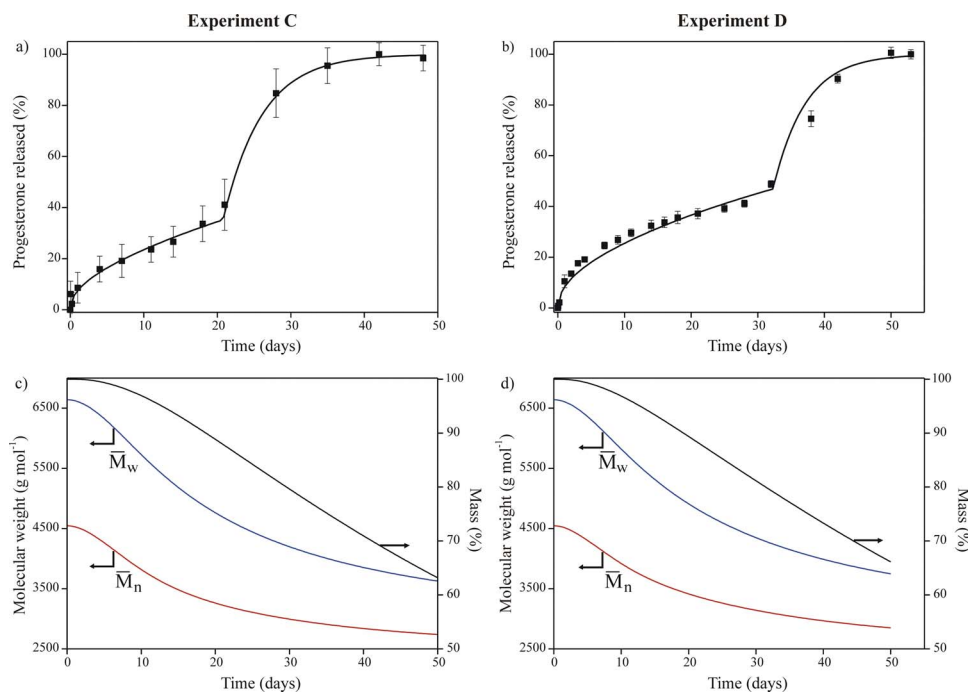

Fig. 5. Experimental and theoretical results for Experiments C ($D_p = 131.3 \pm 45.8 \mu\text{m}$) and D ($D_p = 87.9 \pm 3.6 \mu\text{m}$). a) and b) *In vitro* release profiles of progesterone; c) and d) Simulated evolutions of average molecular weights and mass loss: \bar{M}_n (—), \bar{M}_w (—), mass loss (—).

matrix. The release phase affected by polymer degradation was not observed in these experiments. This is because a complete release of the encapsulated hormone takes place in a few days, during which the degradation effects of the polymeric matrix are not still important. In addition, degradation of the polymer proceeds at a slower rate for smaller microspheres because of the autocatalysis effect.

The simulation results of the Degradation Module and the predictions of progesterone release from the different PLGA microparticles are presented in Figs. 5 and 6. For simulations corresponding to Degradation Module, the parameters adjusted in our previous work (Busatto et al., 2017) were used (Table 2). Three stages can be identified from the evolutions of average molecular weights for microparticles of Experiments C and D: initially the degradation proceeds slowly due to the

Table 2
Kinetic constants and transport parameters taken from Busatto et al. (2017).

k_{L-L} ($\text{L mol}^{-1} \text{s}^{-1}$)	2.55×10^{-7}	
k_{G-G} ($\text{L mol}^{-1} \text{s}^{-1}$)	1.27×10^{-6}	
k_{L-G} ($\text{L mol}^{-1} \text{s}^{-1}$)	7.63×10^{-7}	
k_{a1} (s^{-1})	5.00×10^{-8}	
k_{a2} (s^{-1}) = k_{a1}/K_a ($K_a = 3.38 \times 10^{-4}$)	1.48×10^{-4}	
D_{diff}^0 ($\text{cm}^2 \text{s}^{-1}$)	1.00×10^{-14}	
k_D	4.00×10^{1a}	7.00×10^{2b}

^a Average diameter $8.94 \pm 3.30 \mu\text{m}$.

^b Average diameter $52.37 \pm 17.73 \mu\text{m}$.

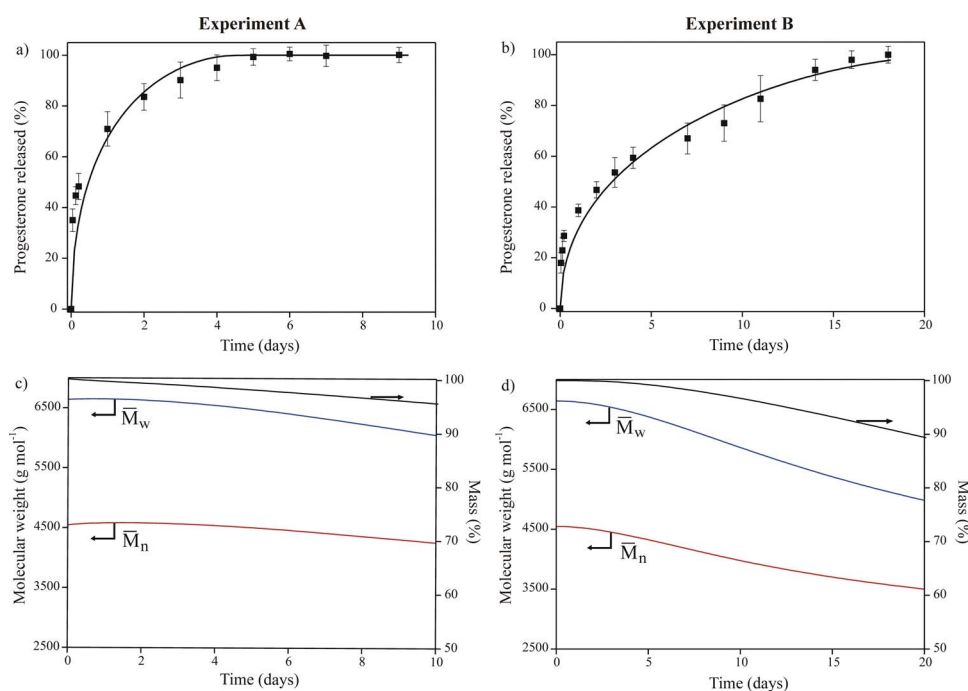

Fig. 6. Experimental and theoretical results for Experiments A ($D_p = 9.3 \pm 4.4 \mu\text{m}$) and B ($D_p = 71.6 \pm 19.3 \mu\text{m}$). a) and b) *In vitro* release profiles of progesterone; c) and d) Simulated evolutions of average molecular weights and mass loss: \bar{M}_n (—), \bar{M}_w (—), mass loss (—).

low concentration of terminal carboxylic acid groups. Then, as degradation proceeds, the number of carboxylic acid groups increases and accelerates the hydrolysis reaction. Finally, the low concentration of ester bonds delays degradation. For microparticles of Experiments A and B, only two stages can be identified from the evolutions of average molecular weights due to the fact that the release process takes place in short period during which polymer degradation is not extensive. In addition, it can be noted that microsphere degradation increases with particle size. The effect of particle size on the degradation profiles is related to the fact that degradation products generated within smaller particles can diffuse easily to the particle surface while in larger particles the length of the diffusion pathways increases. Therefore, degradation products are accumulated within the particle and have the potential to further catalyse the degradation of the remaining polymeric matrix. The effect of autocatalysis can explain the variation of t^* parameter with the average particle size. From the simulated evolutions of \overline{M}_n and \overline{M}_w , it is possible to estimate a range of molecular weights at which the mass transport mechanism changes. The estimated ranges of \overline{M}_n and \overline{M}_w were 3100–3200 and 4300–4700 g mol⁻¹, respectively. This results are in agreement with reported data in similar experimental conditions (Berchane et al., 2007; Raman et al., 2005).

Mass loss of microparticles increases with particle size. In all experiments, low mass loss (< 10%) was observed for during the first 5 days followed by a progressive increment. This can be explained by the fact that polymer must undergo sufficiently extensive degradation to produce water-soluble monomers and oligomers, thus no reduction in mass is observed at the beginning of the degradation experiment. For microparticles of Experiments A and B, low mass loss was observed due to the fact that complete release of the drug occurs in a short period during which the generation of water-soluble monomers and oligomers is negligible.

Release Module was used to simulate the progesterone release process. To this effect, the model was adjusted and validated with the experimental data. For microspheres of Experiments A and B, the kinetic constant k_a and the transport parameters D_{PG}^0 and k_D were simultaneously adjusted to simulate the progesterone release profiles. For microspheres of Experiments C and D, the kinetic constant k_d was adjusted. The values of the input data, the kinetic constants and the transport parameters used to fit the model are shown in Table 3.

The simulation results are shown in Figs. 5 and 6a and b. A very good agreement with the experimental results is observed. The initial effective diffusion coefficient of progesterone vary with the initial drug loading of microparticles and the values are in agreement with those reported in PLA matrices under similar conditions (Pitt et al., 1979). The increase of the drug effective diffusivity during degradation of the polymeric matrix was related to the evolutions of \overline{M}_w and to the adjustment parameter k_D . This allowed coupling the evolution of the particle's porosity to the effective diffusivity. On the other hand, the value of k_a was the same for all experiments, indicating that the distribution of the amorphous phase in the polymeric matrix did not vary with the particle size.

Table 3
Input data, kinetic constants and transport parameters of the model.

C_{PGm} (mg cm ⁻³)	Turino (2012)	25
k_a (s ⁻¹)		1.0×10^{-2}
k_d (s ⁻¹)		2.3×10^{-6}
D_{PG}^0 (cm ² s ⁻¹)		1.2×10^{-12} (Experiment A)
		9.8×10^{-12} (Experiment B)
		1.8×10^{-12} (Experiment C)
		9.0×10^{-13} (Experiment D)
D_{PGb} (cm ² s ⁻¹)	Sieminska et al. (1997)	1.0×10^{-8}
k_D		2.5

Other theoretical simulations are shown in Fig. 7. The effects of particle size and initial molecular weight of the polymer on the release profiles were studied. Fig. 7a shows the simulated release profiles for microspheres with different sizes. It can be noted that the release rate decreases with particle size and the polymer degradation effects are negligible for microspheres with a size less than 75 μ m. Larger microparticles show a triphasic release profile and the t^* values vary with the particle size, being smaller as particle size increases because polymer degradation is faster for larger microparticles. Fig. 7b shows the simulated release profiles for different initial molecular weights of the polymer for microspheres with average diameters of 50 and 100 μ m. Microparticles with a size of 50 μ m present biphasic release profiles for all molecular weights because polymer degradation effects are negligible in the release period, and drug diffusion through the polymeric matrix is the main transport mechanism. On the other hand, microspheres with a size of 100 μ m show a release profile influenced by the degradation of the polymeric matrix. The t^* values vary according to the initial molecular weight of the polymer. The degradation of the polymer with a low molecular weight is enhanced because oligomers can rapidly reach the molecular weight required to dissolve in the medium.

4. Conclusion

Progesterone-loaded PLGA microspheres were prepared by the solvent extraction/evaporation and microfluidic techniques. Microspheres were characterized in terms of size distribution, morphology, drug loading and thermal properties of the polymeric matrix and the drug. The effect of particle size, polydispersity and polymer degradation on the *in vitro* release rate of the hormone was investigated. Smaller microspheres showed a biphasic release profile comprising initial "burst" effect and drug release controlled by the diffusion of the drug through the polymeric matrix, whereas larger particles presented a triphasic release profile including an additional phase controlled by polymer degradation. This behavior is related to the fact that complete drug release was achieved in a few days for smaller microparticles, during which polymer degradation effects are still negligible. A mathematical model for the prediction of progesterone release from different sized-microspheres was developed. The model takes into account the intraparticle dissolution and diffusion of the drug as well as the autocatalytic effect of polymer degradation. The model predictions show a very good agreement with the experimental results. The model can be used to select an appropriate particle size and/or polymer molecular weight in order to achieve a desired drug release profile according to the therapy.

Acknowledgments

The authors are grateful for the support of this work by the Consejo Nacional de Investigaciones Científicas y Técnicas (CONICET) and Universidad Nacional del Litoral (UNL).

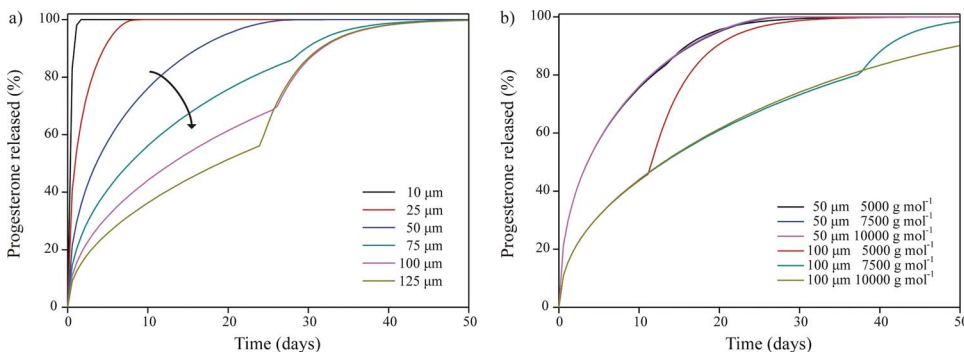

Fig. 7. Theoretical effects of particle size and polymer initial molecular weight on progesterone release from PLGA microparticles. a) Effect of particle size; b) Effect of polymer initial molecular weight.

Appendix A. Mathematical model

Degradation Module

This module is based on the detailed hydrolysis mechanism presented in Scheme 1

Scheme 1: Hydrolysis mechanism of PLGA microspheres taken from Busatto et al. (2017)

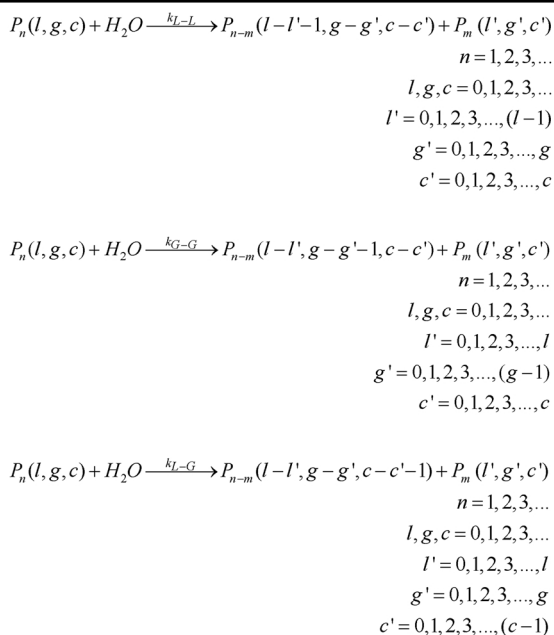

where $P_n(l, g, c)$ represents a polymer chain of length n with l , g and c , Lactic-Lactic (L-L), Glycolic-Glycolic (G-G) and Lactic-Glycolic (L-G) ester bonds, respectively; and k_{L-L} , k_{G-G} , k_{L-G} are the hydrolysis constants corresponding to L-L, G-G and L-G ester bonds.

On the basis of the hydrolysis mechanism, the following mass balances are derived:

$$\begin{aligned}
 \frac{\partial \sum_{l=0}^{\infty} \sum_{g=0}^{\infty} \sum_{c=0}^{\infty} [P_n]}{\partial t} &= \frac{1}{r^2} \frac{\partial}{\partial r} \left(r^2 D_{P_n} \frac{\partial \sum_{l=0}^{\infty} \sum_{g=0}^{\infty} \sum_{c=0}^{\infty} [P_n]}{\partial r} \right) - k_{L-L} l \sum_{l=0}^{\infty} \sum_{g=0}^{\infty} \sum_{c=0}^{\infty} [P_n] [H^+] - k_{G-G} g \sum_{l=0}^{\infty} \sum_{g=0}^{\infty} \sum_{c=0}^{\infty} [P_n] [H^+] \\
 &\quad - k_{L-G} c \sum_{l=0}^{\infty} \sum_{g=0}^{\infty} \sum_{c=0}^{\infty} [P_n] [H^+] + \\
 &\quad + \sum_{l=0}^{\infty} \sum_{g=0}^{\infty} \sum_{c=0}^{\infty} \left\{ \sum_{m=n+1}^{\infty} (\sum_{k=l+1}^{\infty} k_{L-L} P_k k [P_m(k, g, c)] + \sum_{h=g+1}^{\infty} k_{G-G} P_h h [P_m(l, h, c)] + \sum_{d=c+1}^{\infty} k_{L-G} P_d d [P_m(l, g, d)] \right\} \\
 n &= 1, 2, 3, \dots ; \quad n < n_s
 \end{aligned} \tag{A.1}$$

where n_s is the critical chain length for oligomers dissolution and D_{P_n} is the effective diffusivity of polymer chains P_n . Note that the chain length n is related to the number of ester bonds as $n = l + g + c + 1$.

The increase of the effective diffusivity during degradation is related to the evolution of the weight-average molecular weight through the following expression (Ford et al., 2011):

$$D_{P_n} = D_{P_n}^0 \left[1 + \left(1 - \frac{\overline{M}_w(t, r)}{\overline{M}_w(t=0)} \right) (k_D - 1) \right] \quad n < n_s \tag{A.2}$$

where $D_{P_n}^0$ is the initial effective diffusivity of the polymer chains, \overline{M}_w is the weight-average molecular weight and k_D is an adjustment parameter related to the effective diffusivities of the species in aqueous solution and in the solid. This equation allows coupling the evolution of the pore

network to the effective diffusivity.

Considering $[P_n^-] = [H^+]$, the following mass balance for acid catalyst H^+ is derived:

$$\frac{d[H^+]}{dt} = k_{a1} \sum_{n=1}^{\infty} \sum_{l=0}^{\infty} \sum_{g=0}^{\infty} \sum_{c=0}^{\infty} [P_n(l, g, c)] - k_{a2} [H^+]^2 \quad (\text{A.3})$$

where k_{a1} and k_{a2} are the direct and reverse acid dissociation constants.

Concerning boundary conditions, the symmetry condition for the concentration of oligomers is applied in the center of the microparticle and sink condition is considered at the microparticle-aqueous medium interface:

$$\left. \frac{\partial [P_n]}{\partial r} \right|_{r=0} = 0 \quad n < n_s \quad (\text{A.4})$$

$$[P_n]_{r=R} = 0 \quad n < n_s \quad (\text{A.5})$$

From Eq. (A.1), the number chain length distribution (NCLD) of the copolymer can be estimated:

$$x_n = \frac{\int_0^R [P_n(l, g, c)] r^2 dr}{\int_0^R \sum_{n=1}^{\infty} \sum_{l=0}^{\infty} \sum_{g=0}^{\infty} \sum_{c=0}^{\infty} [P_n(l, g, c)] r^2 dr} \quad (\text{A.6})$$

Multiplying Eq. (A.6) by the average molecular weight of the repeating unit (M_{RU}), the weight chain length distribution (WCLD) can be calculated:

$$x_w = \frac{\int_0^R [P_n(l, g, c)] n M_{RU} r^2 dr}{\int_0^R \sum_{n=1}^{\infty} \sum_{l=0}^{\infty} \sum_{g=0}^{\infty} \sum_{c=0}^{\infty} [P_n(l, g, c)] n M_{RU} r^2 dr} \quad (\text{A.7})$$

where $M_{RU} = x_{L-L} M_{L-L} + x_{G-G} M_{G-G} + x_{L-G} M_{L-G}$. In this equation, M_{L-L} , M_{G-G} and M_{L-G} are the molar masses of the corresponding ester repeating units and x_{L-L} , x_{G-G} and x_{L-G} represents the molar fraction of L–L, G–G and L–G ester bonds, given by:

$$x_{L-L} = \frac{[E_{L-L}]}{[E_{L-L}] + [E_{G-G}] + [E_{L-G}]} \quad (\text{A.8})$$

$$x_{G-G} = \frac{[E_{G-G}]}{[E_{L-L}] + [E_{G-G}] + [E_{L-G}]} \quad (\text{A.9})$$

$$x_{L-G} = \frac{[E_{G-L}]}{[E_{L-L}] + [E_{G-G}] + [E_{L-G}]} \quad (\text{A.10})$$

The copolymer average molecular weights are estimated as follow:

$$\bar{M}_n = \frac{\int_0^R \sum_{n=1}^{\infty} \sum_{l=0}^{\infty} \sum_{g=0}^{\infty} \sum_{c=0}^{\infty} [P_n(l, g, c)] n M_{RU} r^2 dr}{\int_0^R \sum_{n=1}^{\infty} \sum_{l=0}^{\infty} \sum_{g=0}^{\infty} \sum_{c=0}^{\infty} [P_n(l, g, c)] r^2 dr} \quad (\text{A.11})$$

$$\bar{M}_w = \frac{\int_0^R \sum_{n=1}^{\infty} \sum_{l=0}^{\infty} \sum_{g=0}^{\infty} \sum_{c=0}^{\infty} [P_n(l, g, c)] (n M_{RU})^2 r^2 dr}{\int_0^R \sum_{n=1}^{\infty} \sum_{l=0}^{\infty} \sum_{g=0}^{\infty} \sum_{c=0}^{\infty} [P_n(l, g, c)] n M_{RU} r^2 dr} \quad (\text{A.12})$$

References

- Allison, S., 2008. Analysis of initial burst in PLGA microparticles. *Expert Opin. Drug Deliv.* 5, 615–628.
- Berchane, N.S., Carson, K.H., Rice-Ficht, A.C., Andrews, M.J., 2007. Effect of mean diameter and polydispersity of PLG microspheres on drug release: experiment and theory. *Int. J. Pharm.* 337, 118–126.
- Busatto, C.A., Pesoa, J., Helbling, I., Luna, J., Estenez, D.A., 2017. Heterogeneous hydrolytic degradation of poly(lactic-co-glycolic acid) microspheres: mathematical modeling. *J. Appl. Polym. Sci.* 134, 45464. <http://dx.doi.org/10.1002/app.45464>.
- Cai, C., Mao, S., Germershaus, O., Schaper, A., Rytting, E., Chen, D., Kissel, T., 2009. Influence of morphology and drug distribution on the release process of FITC-dextran-loaded microspheres prepared with different types of PLGA. *J. Microencapsul.* 26, 334–345.
- Casalini, T., Rossi, F., Lazzari, S., Perale, G., Masi, M., 2014. Mathematical modeling of PLGA microparticles: from polymer degradation to drug release. *Mol. Pharm.* 11, 4036–4048.
- Chen, W., Palazzo, A., Hennink, W.E., Kok, R.J., 2017. Effect of particle size on drug loading and release kinetics of gefitinib-loaded PLGA microspheres. *Mol. Pharm.* 14, 459–467.
- Duncanson, W.J., Lin, T., Abate, A.R., Seiffert, S., Shah, R.K., Weitz, D.A., 2012. Microfluidic synthesis of advanced microparticles for encapsulation and controlled release. *Lab Chip* 12, 2135–2145.
- Faisant, N., Siepmann, J., Benoit, J.P., 2002. PLGA-based microparticles: elucidation of mechanisms and a new, simple mathematical model quantifying drug release. *Eur. J. Pharm. Sci.* 15, 355–366.
- Ford Versypt, A.N., Pack, D.W., Braatz, R.D., 2013. Mathematical modeling of drug delivery from autocatalytically degradable PLGA microspheres – a review. *J. Control. Release* 165, 29–37.
- Ford, A.N., Pack, D.W., Braatz, R.D., 2011. Multi-scale modeling of PLGA microparticle drug delivery systems. In: Pistikopoulos, E.N., Georgiadis, M.C., Kokossis, A.C. (Eds.), *Comput. Aided Chem. Eng.* 29. Elsevier, pp. 1475–1479.
- Fredenberg, S., Wahlgren, M., Reslow, M., Axelsson, A., 2011. The mechanisms of drug release in poly(lactic-co-glycolic acid)-based drug delivery systems – a review. *Int. J. Pharm.* 415, 34–52.
- Fu, X., Ping, Q., Gao, Y., 2005. Effects of formulation factors on encapsulation efficiency and release behaviour in vitro of huperzine A-PLGA microspheres. *J. Microencapsul.* 22, 705–714.
- Garner, J., Skidmore, S., Park, H., Park, K., Choi, S., Wang, Y., 2015. A protocol for assay of poly(lactide-co-glycolide) in clinical products. *Int. J. Pharm.* 495, 87–92.
- Gasmí, H., Siepmann, F., Hamoudi, M.C., Danede, F., Verin, J., Willart, J.-F., Siepmann, J., 2016. Towards a better understanding of the different release phases from PLGA microparticles: dexamethasone-loaded systems. *Int. J. Pharm.* 514, 189–199.
- Guo, W., Quan, P., Fang, L., Cun, D., Yang, M., 2015. Sustained release donepezil loaded PLGA microspheres for injection: preparation, in vitro and in vivo study. *Asian J. Pharm. Sci.* 10, 405–414.
- Han, F.Y., Thurecht, K.J., Whittaker, A.K., Smith, M.T., 2016. Bioerodable PLGA-based microparticles for producing sustained-release drug formulations and strategies for improving drug loading. *Front. Pharmacol.* 7, 185.
- Hines, D.J., Kaplan, D.L., 2013. Poly (lactic-co-glycolic acid) controlled release systems: experimental and modeling insights. *Crit. Rev. Ther. Drug Carrier Syst.* 30, 257–276.
- Jameelaa, S.R., Kumaryb, T.V., Lal, A.V., Jayakrishnana, A., 1998. Progesterone-loaded chitosan microspheres: a long acting biodegradable controlled delivery system. *J. Control. Release* 52, 17–24.
- Ji, Y., Lesniak, A.K., Prudic, A., Paus, R., Sadowski, G., 2016. Drug release kinetics and

- mechanism from PLGA formulations. *AIChE J.* 62, 4055–4065.
- Klose, D., Siepmann, F., Elkharraz, K., Krenzlin, S., Siepmann, J., 2006. How porosity and size affect the drug release mechanisms from PLGA-based microparticles. *Int. J. Pharm.* 314, 198–206.
- Leon, R.A.L., Somasundar, A., Badruddoza, A.Z.M., Khan, S.A., 2015. Microfluidic fabrication of multi-drug-loaded polymeric microparticles for topical glaucoma therapy. *Part. Part. Syst. Charact.* 32, 567–572.
- Nath, A., Sitruk-Ware, R., 2009. Parenteral administration of progestins for hormonal replacement therapy. *Eur. J. Contracept. Reprod. Health Care* 14, 88–96.
- Pitt, C.G., Jeffcoat, A.R., Zweidinger, R.A., Schindler, A., 1979. Sustained drug delivery systems. I. The permeability of poly(ϵ -caprolactone), poly(DL-lactic acid), and their copolymers. *J. Biomed. Mater. Res.* 13, 497–507.
- Raman, C., Berkland, C., Kim, K., Pack, D.W., 2005. Modeling small-molecule release from PLG microspheres: effects of polymer degradation and nonuniform drug distribution. *J. Control. Release* 103, 149–158.
- Rathbone, M.J., 2012. Delivering drugs to farmed animals using controlled release science and technology. *Int. J. Pharm.* 433, 118–128.
- Regnier-Delplace, C., Thillaye du Boullay, O., Siepmann, F., Martin-Vaca, B., Degrave, N., Demonchaux, P., Jentzer, O., Bourissou, D., Siepmann, J., 2013. PLGA microparticles with zero-order release of the labile anti-Parkinson drug apomorphine. *Int. J. Pharm.* 443, 68–79.
- Sansdrap, P., Moës, A.J., 1997. In vitro evaluation of the hydrolytic degradation of dispersed and aggregated poly(DL-lactide-co-glycolide) microspheres. *J. Control. Release* 43, 47–58.
- Sieminska, L., Ferguson, M., Zerda, T.W., Couch, E., 1997. Diffusion of steroids in porous sol-gel glass: application in slow drug delivery. *J. Sol-Gel Sci. Technol.* 8, 1105–1109.
- Siepmann, J., Elkharraz, K., Siepmann, F., Klose, D., 2005. How autocatalysis accelerates drug release from PLGA-based microparticles: a quantitative treatment. *Biomacromolecules* 6, 2312–2319.
- Siepmann, J., Faisant, N., Benoit, J.P., 2002. A new mathematical model quantifying drug release from bioerodible microparticles using Monte Carlo simulations. *Pharm. Res.* 19, 1885–1893.
- Su, Z., Sun, F., Shi, Y., Jiang, C., Meng, Q., Teng, L., Li, Y., 2009. Effects of formulation parameters on encapsulation efficiency and release behavior of risperidone poly(D,L-lactide-co-glycolide) microspheres. *Chem. Pharm. Bull.* 57, 1251–1256.
- Tanetsugu, Y., Tagami, T., Terukina, T., Ogawa, T., Ohta, M., Ozeki, T., 2017. Development of sustainable release system for ranibizumab biosimilar using poly(lactic-co-glycolic acid) biodegradable polymer based microspheres as a platform. *Biol. Pharm. Bull.* 40, 145–150.
- Thakur, V.K., Thakur, M.K., 2015. Handbook of polymers for pharmaceutical technologies. Processing and Applications, vol. 2. John Wiley & Sons, pp. 151–172 Chapter 6.
- Turino, L.N., 2012. Desarrollo de sistemas inyectables biodegradables con formación in situ para la liberación sostenida de drogas veterinarias. Doctoral Thesis. Universidad Nacional del Litoral, Santa Fe, Argentina.
- Wang, S., Shi, X., Gan, Z., Wang, F., 2015. Preparation of PLGA microspheres with different porous morphologies. *Chin. J. Polym. Sci.* 33, 128–136.
- Weibel, M.I., Badano, J.M., Rintoul, I., 2014. Technological evolution of hormone delivery systems for estrous synchronization in cattle. *Int. J. Livest. Res.* 4, 20–40.
- Xu, Q., Hashimoto, M., Dang, T.T., Hoare, T., Kohane, D.S., Whitesides, G.M., Langer, R., Anderson, D.G., 2009. Preparation of monodisperse biodegradable polymer microparticles using a microfluidic flow-focusing device for controlled drug delivery. *Small* 5, 1575–1581.