

# A long distance RT-PCR able to amplify the *Pestivirus* genome

Leandro R. Jones<sup>a,\*</sup>, Rubén O. Zandomeni<sup>b</sup>, E. Laura Weber<sup>a</sup>

<sup>a</sup> Instituto de Virología, CICVyA, INTA-Castelar, CC 25, (1712) Castelar, Buenos Aires, Argentina

<sup>b</sup> Instituto de Microbiología y Zoología Agrícola, CICVyA, INTA-Castelar, CC 25, (1712) Castelar, Buenos Aires, Argentina

Received 23 June 2005; received in revised form 3 January 2006; accepted 10 January 2006

Available online 23 February 2006

## Abstract

A method to amplify long genomic regions (up to ~12.3 kb) from pestiviruses in one RT-PCR is described. The difficulty in designing conserved *Pestivirus* primers for the amplification of genomes from highly divergent isolates simply by means of overlapping segments is demonstrated using new bioinformatic tools. An alternative procedure consisting of optimizing the length of the genomic cDNA fragments and their subsequent amplification by polymerase chain reaction (PCR) using a limited set of specific primers is described. The amplification of long DNA fragments from a variety of sources, including genomic, mitochondrial, and viral DNAs as well as cDNA produced by reverse transcription (RT) has been achieved using this methodology, known as long distance PCR. In the case of viruses, it is necessary to obtain viral particles from infected cells prior to RT procedures. This work provides improvements in four steps of long distance RT-PCR (L-RT-PCR): (i) preparation of a viral stock, (ii) preparation of template RNA, (iii) reverse transcription and (iv) amplification of the cDNA by LD-PCR. The usefulness of L-RT-PCR is discussed in the light of current knowledge on pestivirus diversity. The genomic sequence of *Singer\_Arg* reference strain obtained using this method is presented and characterized.

© 2006 Elsevier B.V. All rights reserved.

**Keywords:** Pestivirus; L-RT-PCR; *Flaviviridae*

## 1. Introduction

Pestiviruses are important livestock pathogens responsible for significant economic losses world-wide (Rice, 1996; Houe, 1999). The presence of bovine pestiviruses in cell cultures and in fetal bovine serum has been recognized as a relevant problem not only in research laboratories but also among biological manufacturers (Nutall et al., 1977).

The genus *Pestivirus* belongs to the family *Flaviviridae*. *Flaviviridae* also includes *Hepacivirus* (*Human hepatitis C virus*, HCV) and *Flavivirus*. There are two *Pestivirus* species that primarily infect bovines: *Bovine viral diarrhoea virus 1* (BVDV 1) and *Bovine viral diarrhoea virus 2* (BVDV 2) (Paton et al., 1995; Becher et al., 1999). Other members of *Pestivirus*, *Classical swine fever virus* (CSFV) and *Border disease virus* (BDV), infect pigs and sheep, respectively (Paton et al., 1995; Becher et al., 1999). Two new species of *Pestivirus* have been recently proposed, each with only one member: Giraffe Isolate and Rein-

deer Isolate (Avalos-Ramirez et al., 2001). Pestiviruses possess a single stranded positive sense RNA genome with a length of 12.3 kb.

Recent studies have shown that BVDV 1 may include more than 12 genotypes (Vilček et al., 2001; Jones et al., 2004). Each viral genotype seems to cause different clinical manifestations (Baule et al., 1997, 2001; Jones et al., 2001, 2004; Fulton et al., 2002). When this report was written, there were only six complete BVDV 1 genomic sequences available in public sequence databases.

Full genome sequencing is used in several areas of virology, from taxonomy and phylogeny (e.g. Herniou et al., 2001; Avalos-Ramirez et al., 2001) to viral molecular biology (e.g. Kümmerer et al., 1998, 2000; Becher et al., 1996). Traditional sequencing strategies can be cumbersome and time consuming due to library construction and screening processes, developing of overlapping RT-PCR reactions and problems related to DNA sequence automation.

Reverse genetics permits the use of cDNA copies of viral RNA genomes to produce detailed studies of molecular features of virus infection, replication, and assembly. For pestiviruses, the availability of full-length cDNAs has relied on laborious

\* Corresponding author. Tel.: +54 11 4621 1676; fax: +54 11 4621 1743.  
E-mail address: [ljones@cicv.inta.gov.ar](mailto:ljones@cicv.inta.gov.ar) (L.R. Jones).

genetic engineering techniques (e.g. Meyers et al., 1996). Furthermore, assembling cDNA clones obtained independently into a full-length sequence can lead to the combination of segments corresponding to different quasispecies.

In the present report, it is shown that finding conserved regions for designing a unique set of RT-PCR primers capable of amplifying many short overlapping cDNA fragments from isolates of different filiation might be impossible. For this reason, an alternative method which is able to amplify long RNA spans was developed. Previous reports have described the amplification of long DNA templates from eukaryotic genomes or molecular clones (Cheng et al., 1994). LD-PCR methods capable of amplifying long viral DNA genomes have been described (Barnes, 1994). Complete double stranded genomic RNA fragments of 0.8–6.8 kb have been successfully amplified (Potgieter et al., 2002). Complete genomes and long genomic regions of up to 10 kb long from other positive stranded RNA viruses have been reverse transcribed and amplified by PCR (Lindberg et al., 1997; Lindberg and Andersson, 1999; Holterman et al., 2000; Lu et al., 2005; Zhang et al., 2001). Long fragments of up to 20 kb from coronavirus genomic RNA have been successfully amplified by using a purification step previous to the RT (Thiel et al., 1997). This success strongly suggested the possibility of amplifying the whole pestiviral genome directly from total RNA; that is, avoiding viral RNA purification procedures.

To our knowledge, there have not been previous attempts to amplify complete *Pestivirus* genomes in vitro. In this report, it is shown that viral genomic RNA spans of up to 12.3 kb can be efficiently amplified by RT followed by LD-PCR directly from total RNA obtained from infected cells. The use of this technique is discussed in the light of current knowledge about pestiviral diversity. The genomic sequence of one of the reference strains used at the authors' laboratory is presented and characterized.

## 2. Materials and methods

### 2.1. Virus culture

The cytopathic (CP) *BVDV 1 Singer* reference strain used at the authors' laboratory (*Singer\_Arg*) was propagated at low (0.01 plaque forming unit/cell) multiplicity of infection (MOI) in MDBK cells grown in minimal essential medium (MEM) supplemented with irradiated fetal bovine serum (FBS). To release all viral particles, cells were freeze–thawed once. At least three passages in cell culture at low MOI were performed.

For plaque forming unit assays, MDBK cells were grown on six wells plates (750,000 cells per well) and inoculated with 500  $\mu$ l of 1:10 serial dilutions of virus suspensions. After incubating at 37 °C for 30 min, the cells were washed with PBS preheated at 37 °C and covered with 2.5% Methyl cellulose/MEM supplemented with 5% FBS. About 72 h later, the monolayers were fixed with 4% formalin and stained with 0.1% *Crystal Violet*.

Strains *T1*, *2B*, *36P* and *66.6* were propagated following standard procedures described elsewhere (Jones and Weber, 2001; Jones et al., 2001).

### 2.2. Total RNA purification and cDNA synthesis

Total RNA from infected cells was extracted using a commercial reagent (Trizol, Promega). Aliquots of 150  $\mu$ l of virus suspensions were added to 850  $\mu$ l of Trizol. Manufacturer instructions were slightly modified, as 1  $\mu$ g of yeast tRNA was added to the mixture prior to the organic extraction phase. Yeast tRNA was prepared at a concentration of 10 mg/ml in a solution of 10 mM Vanadyl Ribonucleoside in DEPC-treated double distilled water. Yeast tRNA was diluted 1:10 in ultra pure water (*GIBCO*) at the moment of being used. RNA pellets were resuspended in 5  $\mu$ l of ultra-pure water and immediately used for RT.

For cDNA synthesis, 1  $\mu$ l of 2 pM specific primer, 1  $\mu$ l of 25 mM dNTPs, 6  $\mu$ l of ultra-pure water (*GIBCO*) and 5  $\mu$ l of RNA suspension were mixed and heated at 65 °C during 6 min. The preparation was chilled on ice for 1 min. Next, 4  $\mu$ l reverse transcriptase buffer (provided by the manufacturer), 1  $\mu$ l of 0.1 M DTT, 1  $\mu$ l (40 U) *RNasin* ribonuclease inhibitor (*Promega*) and 200 U (1  $\mu$ l) *Superscript III RNase<sup>(-)</sup> Reverse Transcriptase* (*Invitrogen*) were added. The mixture was incubated for 1 h at 55 °C; after which enzyme inactivation was carried out at 70 °C for 15 min. cDNA solutions were immediately used or stored at –20 °C. The performance of reverse transcription protocols published elsewhere (Jones and Weber, 2001; Jones et al., 2001) was also investigated.

### 2.3. LD-PCR

The amplification of cDNA targets longer than approximately 1 kb requires removal of complementary RNA. In order to achieve this, RNA/cDNA hybrids were treated by adding Na(OH) to a final concentration of 0.1N, or with 2 U of Ribonuclease H (*Invitrogen*). In both cases, samples were incubated for 20 min at 37 °C.

PCR reactions were carried out in 50  $\mu$ l volume, using 2.5 U of *AccuPrime Taq DNA Polymerase High Fidelity* (*Invitrogen*), *Buffer I* (Provided by the manufacturer; 10 $\times$  buffer: 600 mM Tris–SO<sub>4</sub> (pH 8.9), 180 mM (NH<sub>4</sub>)<sub>2</sub>SO<sub>4</sub>, 20 mM MgSO<sub>4</sub>, 2 mM dGTP, 2 mM dATP, 2 mM dCTP, 2 mM dTTP, 10% glycerol, thermostable *AccuPrime<sup>TM</sup>* protein), 2  $\mu$ l cDNA obtained as described above, and a final concentration of 0.5  $\mu$ M of each PCR primer. LD-PCR cycling profiles were: 15 s at 94 °C, followed by 35 cycles of 15 s at 94 °C, 15 s at 55 °C and 7–17 min (depending on the template's length) at 68 °C; these cycles were followed by a final extension period of 10 min at 68 °C. LD-PCR protocols published elsewhere (Barnes, 1994; Cheng et al., 1994) were also analyzed as described in Section 3.4. All the reactions were performed on a Perkin-Elmer 2400 thermocycler.

Aliquots of the LD-PCR amplification products were analyzed on 0.8% agarose standard horizontal gels. DNA was stained with 0.5  $\mu$ g/ $\mu$ l ethidium bromide. Molecular markers ( $\lambda$  DNA digested with *HindIII* and/or 1 kb *DNA ladder* from *Invitrogen*) and precision molecular mass standards (*Bio-Rad*) were included when needed.

The identity of PCR amplicons was assessed by comparison to molecular markers and by sequencing (details on sequencing protocols are given in Section 2.5).

#### 2.4. Bioinformatic analyses

Diversity plots were generated by a computer application developed for this study. The program uses Fitch's parsimony (Fitch, 1971) to measure the number of substitutions on an alignment block given a phylogenetic tree. Our program also counts the number of variable columns in the block. The programming language used was *OCaml* (<http://caml.inria.fr/index.en.html>), which allows portability to a wide range of platforms. The output, termed a diversity profiles, consists of: (i) the number of nucleotidic substitutions as implied by phylogenetic tree and (ii) the number of alignment columns with nucleotidic variation. The alignment block width is chosen by the user. The difference between our approach and previous attempts to measure sequence diversity is the incorporation of phylogenetic information. The use of phylogenetic trees provides a predictive component to the diversity profiles—the analysis is expected to be robust upon the addition of sequence data.

Secondary priming sites, together with inter- and intraprimer complementation, was analyzed by the program OLIGO 4.0 (National Biosciences, Plymouth, MN, USA).

#### 2.5. Sequencing and evolutionary analyses

Nucleotide sequences at amplicon ends were obtained using PCR primers. Sequencing reactions were performed as described elsewhere (Jones and Weber, 2001; Jones et al., 2001). Complete genomic amplicons were sequenced by MacroGen shotgun sequencing service (<http://www.macrogen.com>).

Sequence alignments were obtained with ClustalW 1.83 (Thompson et al., 1994), running under Linux Red Hat 6.3. Insertions corresponding to cytopathogenic strains were removed from the alignment using Proseq program (Filatov, 1999).

Phylogenetic trees were reconstructed by parsimony, using the program TNT (Goloboff et al., 2003; Hovenkamp, 2004; Giribet, 2005). The sequences used in evolutionary analyses were *CP7* (GenBank GI:1518835), *Oregon* (GI:2789676), *C413* (GI:2183250), *ILLNC* (GI:2149468), *890* (GI:902376), *SD1* (GI:289507), *Osloss* (GI:323229), *NADL* (GI:7960755) and *New York 93* (GI:22094502). BDV (strain *BD31*, GI:9629212), CSFV (strain *Brescia*, GI:9626724), *Giraffe* isolate (GI:15282441) and *Reindeer* isolate (GI:15282443) were used as outgroups.

Bootsampling analyses were performed as described elsewhere (Jones and Weber, 2004).

### 3. Results

#### 3.1. Bioinformatic analyses and primer design

Although viral genomes are generally small, the localization of conserved regions of sequence over an alignment of

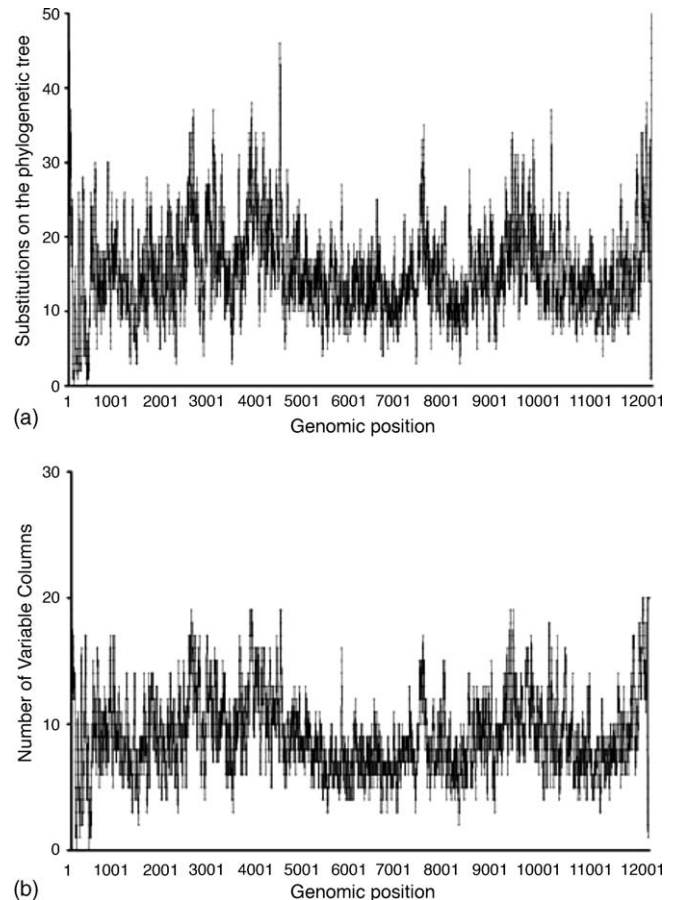

Fig. 1. Diversity plots corresponding to an alignment of pestiviral genomes. A window of 20 nt was slid in steps of 1 nt across the whole alignment. For each step, the length (substitutions on the phylogenetic tree; panel a) and the number of variable columns of the block (panel b) were calculated. Further details on calculations are given in Section 2.4.

genomes is difficult by inspection. For this reason, a computer program that measures nucleotidic diversity on alignment blocks of user-defined width was written (see Section 2.4 for details).

Fig. 1 depicts the analysis of an alignment of pestiviral genomes. Fig. 1a shows that only two regions of the genome (located near to the 5'-end) present invariable blocks. Fig. 1b shows a profile calculated by counting the number of variable columns on each possible block of 20 columns. Analogous analyses using 18–22 nt long blocks resulted in similar profiles. These results explain the difficulty of finding primers that can anneal to genomic sequences from a broad taxonomic range. That is why it was decided to use a strategy based on the amplification of one or few long genomic regions. As discussed in Section 4, a L-RT-PCR is more efficient and accurate than amplifying many short RT-PCR overlapping fragments covering the whole genome.

Based on the diversity profiles, primers were derived from moderately conserved regions at central portions and at 3'- and 5'-ends of the genome. Eleven primers (Table 1), allowing the amplification of large genomic regions, were selected from these regions (Fig. 2).

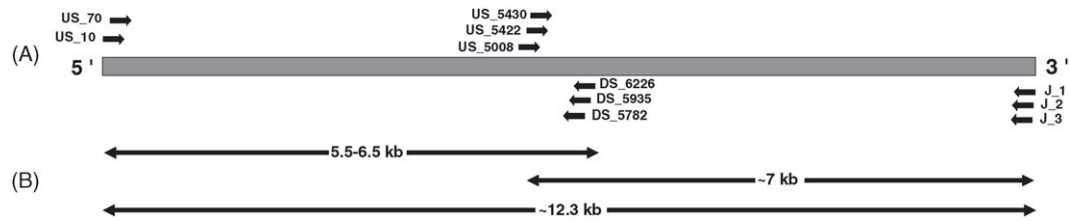

Fig. 2. Schematic representation of L-RT-PCR strategies. Primer locations and lengths of L-RT-PCR products are given. A: Position of the primers relative to genomic RNA. B: Relative position of LD-PCR amplicons. Primer sequences are given in Table 2.

### 3.2. Virus culture, RNA purification and cDNA synthesis

Total RNA from infected cells was partially purified following standard procedures. Nevertheless, it is worth mentioning that the incorporation of a tRNA carrier represented an increase in DNA yield (data not shown). Different cDNA synthesis conditions, including two PCR priming strategies (random and specific), two RT protocols and different reaction temperatures were investigated.

The efficacy of different PCR priming strategies for production of long cDNAs was compared using a set of primer pairs able to amplify fragments of diverse lengths. These analyses demonstrated that random priming was inefficient for templates longer than 3.5 kb. Once established that specific priming was better to amplify long RNA templates than random priming, the production of long or nearly full-length cDNAs was verified using a PCR directed to the far 5'-genomic region. These analyses showed that production of cDNAs running up to the 5'-end of genomic RNA was efficient under the conditions described in Section 2.2 (Fig. 3). The same strategy was used to check the quality of cDNA produced with and without a denaturation step in the RT. The results showed that RNA denaturation prior to the RT was necessary to obtain full-length cDNAs (Fig. 3).

The high thermal stability of the reverse transcriptase used, allowed us to test different reaction temperatures (35, 40, 45, 50 and 55 °C). Although no differences in yield among the cDNAs obtained under such conditions were detected, a temperature of 55 °C was used in subsequent reactions in order to minimize the formation of RNA secondary structures and to prevent unspecific annealing.

Table 1  
Primers used to amplify large fragments of the pestiviral genome

Primer	Sequence	Position <sup>a</sup>
US_10	CTC GTA TAC RYA TTG GRC A	10–28
US_70	GCG AAG GCC GAA AAG AGG CTA	70–90
US_5008	CAA TAY ACC GCT WGG GGR CA	5008–5027
US_5422	ACY GAT GAG ACW GAG TAT GG	5422–5441
US_5430	GAC AGA GTA TGG YGT CAA GAC	5430–5450
DS_5782	TGC YTR AAG TCY CCC CTR TTC AT	5782–5860
DS_5935	CTN GGR TGT TTC AAT CTC AT	5935–5916
DS_6226	GCT ATR AAT TCY TCT ATT GGG TG	6226–6204
J.1	CCT CAY ACA GCT AAA GTG CT	12259–12239
J.2	ACA GCT AAA GTG CTK WGT GC	12243–12223
J.3	TGT AGT GTT WNC TTG AGG TAG ATA A	12227–12202

Fig. 2 provides a graphical scheme indicating the location of primers relative to the genomic RNA.

<sup>a</sup> Positions (5' to 3') relative to the coding sequence of NADL reference strain.

The cell culture passages at low MOI performed on strain *Singer\_Arg* appear to increase DNA yields in LD-PCR reactions. These results are depicted in Fig. 4, which shows an analysis of L-RT-PCRs from viruses multiplied by different methods.

### 3.3. LD-PCR

Based on previous reports (Barnes, 1994; Cheng et al., 1994; Lindberg et al., 1997; Holterman et al., 2000), different DNA polymerases, additives and cycling profiles were surveyed.

Two cycling strategies were tested, one consisting of a two-temperature thermal cycling and other of a three-temperature scheme. The two-temperature cycling consisted of a denaturing stage at 94 °C followed by 35 cycles of 10 s at 94 °C and 7–17 min (depending on template length) of an annealing and extension at 68 °C. Using this pattern, many unspecific products ranging from approximately 5–12 kb were obtained. Thus, for further experiments, it was decided to use the three-step cycling strategy which consists of a denaturing stage at 94 °C during 15 s and 35 cycles of 94 °C for 15 s, 55 °C for 15 s and 68 °C for 7–17 min (depending on amplicon lengths).

As previously reported (Barnes, 1994), PCR yield decreased with increased length of precycling denaturation. We assayed denaturation steps of 10, 15, 20, 25 and 30 s, 1 and 2 min. The best results were obtained with shorter denaturation periods (10 and 15 s, data not shown).

As expected, primers and Mg<sup>++</sup> concentrations were critical to obtain specific and efficient amplifications. Primer concentrations of 0.5–1 μM were adequate for both half and full-length

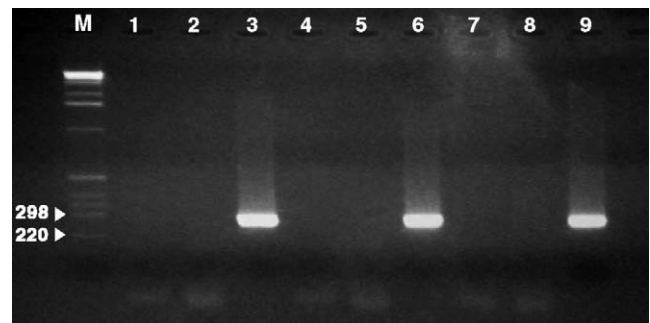

Fig. 3. Analyses of long cDNAs produced using primer J2 (Table 2, Fig. 3). A PCR directed to the far 5'-genomic end was performed in order to check the production of full-length cDNA runs. cDNAs from three independent RTs were used as PCR templates. Lanes 1, 4 and 7 correspond to negative controls; other lanes correspond to reactions made without (2, 5, 8) or with (3, 6, 9) a denaturation/annealing step. The oligonucleotides directed against the 5'-genomic region were primers 324 and 326 (Vilček et al., 1994).

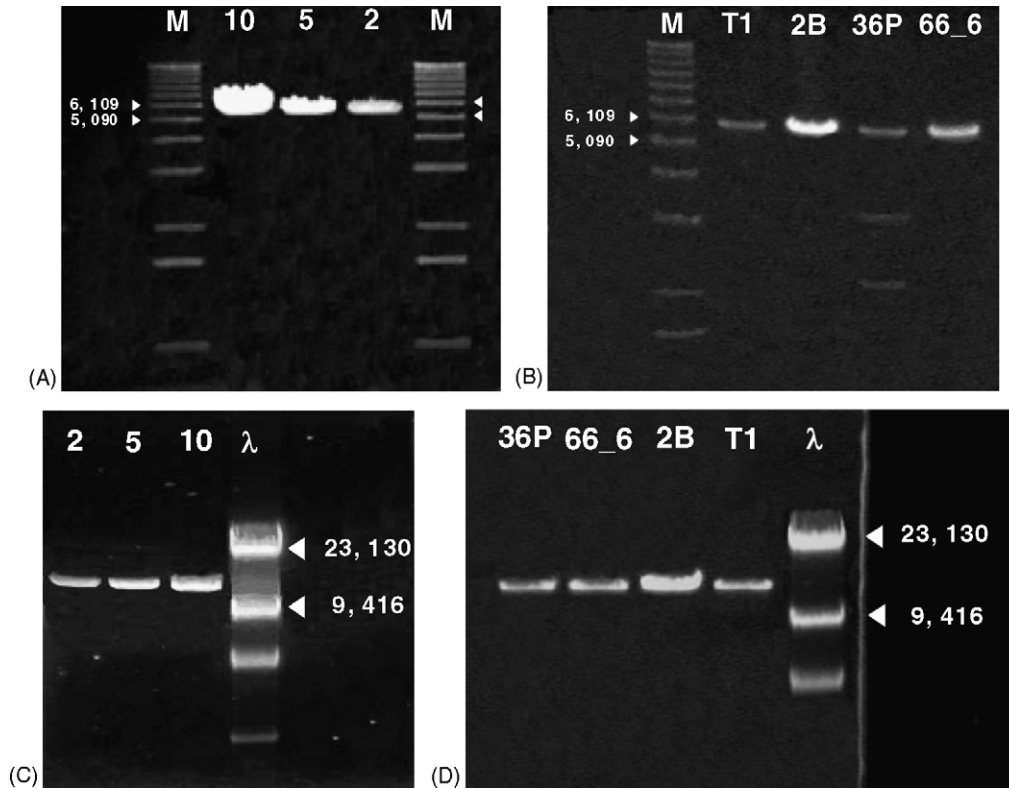

Fig. 4. Agarose gel analyses of half (A, B) and full (C, D) genomic L-RT-PCR amplifications. Lanes marked 2, 5 and 10 correspond to 2, 5 and 10% aliquots of the LD-PCR product, respectively. In the case of L-RT-PCRs from strains *T1*, *2B*, *36P* and *66.6*, all lanes were loaded with 20% aliquots of LD-PCR products. Molecular markers are 1 kb ladder (M) and phage  $\lambda$  DNA digested with *Hind*III ( $\lambda$ ). RT primer were DS\_5782 (A, B) and J\_2 (C, D); LD-PCR primers pairs were US\_10/DS\_5782 or US\_10/J\_3 (see Table 2 and Fig. 3 for primer details).

amplification.  $Mg^{++}$  content was critical for DNA yield. Fig. 5 exemplifies the effect of different primer and  $Mg^{++}$  concentrations. As observed, the optimal primer concentration seems to be between 0.5 and 1  $\mu M$ . The use of a 4 mM concentration of  $Mg^{++}$  produced a clear drop in DNA yield.

*Taq* DNA polymerase, when used alone, was capable of amplifying 5'-half genomic runs (5.5–6.5 kb), although DNA

yields were low and experiments were difficult to reproduce. A mixture of *Taq* DNA Polymerase and *Pfu* DNA polymerase in a 1:1000 units ratio was able to amplify long cDNA targets, especially when co-solvents (glycerol or DMSO) and bovine seroalbumine were added to the PCR mix. Nevertheless, amplicons were barely detectable on agarose gels (Fig. 6). Conversely, the commercial mixture containing a high-fidelity *Taq* polymerase and *Pyrococcus* species GB-D polymerase was able to amplify full-length cDNAs producing DNA amounts that can be detected by ethidium bromide staining on agarose gels (Fig. 4).

All the primers described in Table 1 were able to produce long PCR products. However, the best results were obtained when RT was performed with primer J2 and cDNA amplification was performed using primers US\_10 and J3 (Table 2).

### 3.4. Sequence analyses

The genomic sequence of strain *Singer Arg* was obtained using this methodology and was deposited in GenBank (accession number DQ088995). Nucleotide composition was 32.4% A, 25.6% G, 21.9% T and 20.1% C. These frequencies are similar to those corresponding to previously described genomes. As expected by known sequences corresponding to the NS2-3 protein (Pellerin et al., 1995), no genomic alterations due to insertions were observed in DQ088995.

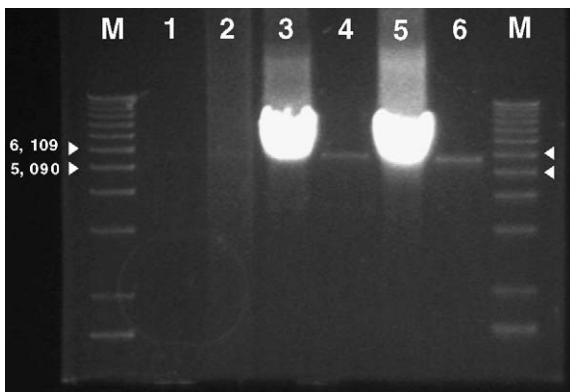

Fig. 5. Effect of varying primer and  $Mg^{++}$  concentrations. Two  $Mg^{++}$  concentrations were used: odd lanes correspond to reactions made at 2 mM  $Mg^{++}$ , while even lanes correspond to concentrations of 4 mM. Primer concentrations were 0.1  $\mu M$  (lanes 1 and 2), 0.5  $\mu M$  (lanes 3 and 4) and 1  $\mu M$  (lanes 5 and 6). RTs were performed using primer 5782; LD-PCRs were made using primers US\_10 and 5782.

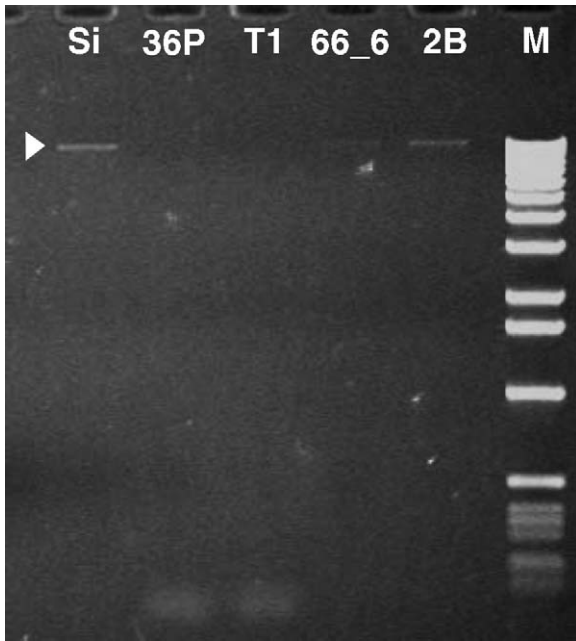

Fig. 6. Electrophoresis analysis of L-RT-PCRs made using a mix of *Taq* and *Pfu* DNA polymerases. The cDNAs were obtained with primer J2 (Table 2, Fig. 3). LD-PCRs were made using primers US\_10 and J3 (Table 2, Fig. 3). *M*: 1 kb ladder. *Si*, *36P*, *T1*, *66\_6*, *2B*: amplicons from strains *Singer*, *36P*, *T1*, *66\_6* and *2B*, respectively.

Table 2  
Performance<sup>a</sup> of different primers and their combinations, when used for L-RT-PCR

RT primers	LD-PCR primers <sup>b</sup>		
	J1	J2	J3
J1	±	+	++
J2	NA	+	+++
J3	NA	NA	+

<sup>a</sup> ±, many unspecific products and relatively low yield of specific DNA; + to +++, increasing DNA yield. NA, not applicable.

<sup>b</sup> Up stream primer was US\_10 (see Table 1 and Fig. 3).

Phylogenetic analyses resulted in a tree in which strain *Singer Arg* belongs to the same clade as strain *NADL*, with a bootstrap support of 100 (Fig. 7). The sliding window analyses (bootscanning) did not provide evidence for recombinant events.

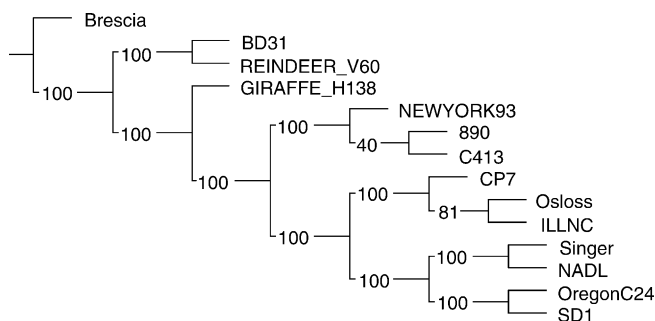

Fig. 7. Parsimony tree showing the relation of strain *Singer Arg* to other pestiviruses. Numbers on branches indicate bootstrap support obtained from 100 resampled (with replacement) data sets.

#### 4. Discussion

As described in Section 3.2, the passages performed at low MOI appear to increase the amount of cDNA obtained when copying long RNA spans. Viral multiplication at low MOI might reduce the proportion of defective non-full-length RNAs, thus favoring the amplification of long RNA templates. Nevertheless further experiments are needed (e.g. Northern blot analyses) to confirm these ideas.

The use of a denaturation step prior to RT was critical, even when amplifying half genomic cDNAs. This could be due to the existence of highly structured regions in the viral genome. A drop in DNA yield was observed when using long denaturing times prior to LD-PCR cycling. It has been previously argued that this can be the result of DNA template depurination (Barnes, 1994), which might be especially important when the PCR template is a single stranded DNA molecule.

Given the reduced size of many viral genomes, PCR amplification of overlapping cDNA fragments covering the entire genome is frequently used to obtain complete genomic sequences (e.g. Avalos-Ramirez et al., 2001; Ridpath and Bolin, 1995; Oberste et al., 2002; Tolou et al., 2001; Behzadian et al., 2005). In pestiviruses, the success of overlapping cDNA amplification can rely on many trial and error assays since primers capable of amplifying one viral isolate or species are usually not necessarily suitable for another (e.g. Ridpath and Bolin, 1995; Avalos-Ramirez et al., 2001; Oberste et al., 2002). The amplification of long or full-length RNA spans using the methods described herein could represent an improvement compared to sequencing many short overlapping cDNA fragments. If the regions in which we located L-RT-PCR primers are relatively conserved, it could be possible to use one set of primers to amplify the genome of many diverse viral genotypes. In the worst case one would need to design primers for each genotype. However, in this situation the number of primers to design and test would be dramatically lower than in the case in which short overlapping PCR fragments are used. Once long amplicons are obtained, they can be easily sequenced by primer walking or shotgun strategies.

It has been suggested that homologous recombination might be frequent in *Pestivirus* evolution (Jones and Weber, 2004). There is no reason to think recombination does not play an important role in quasispecies variation. The methods presented herein would be used for amplifying and cloning complete viral genomes. This could permit using traditional strategies of quasispecies analysis (RT-PCR, cloning and analysis of molecular clones, e.g. Jones et al., 2002) to study the implication of recombination in viral mutant spectra diversification. Recombination also represents a challenge to viral taxonomy, since recombinant strains can be mosaics of different taxonomic entities (e.g. Kalinina et al., 2002; Jones and Weber, 2004). Thus, deeper studies on virus taxonomy must rely on whole genomic analyses.

Summarizing, the present work demonstrates that the whole genomic RNA from pestiviruses can be efficiently amplified by RT followed by LD-PCR. These methods might drive genomic analyses of *Pestivirus* genetic variants. The possibility of cloning full-length cDNAs might be useful to study viral recombina-

tion, especially in quasispecies analyses. Genetically modified infectious RNA can be obtained by cloned cDNA transcription or from LD-PCR amplicons, avoiding the long process of constructing full-length cDNA clones by traditional methods. Thus, the techniques reported here could also be helpful for studies on *Pestivirus* molecular biology.

## Acknowledgments

The authors want to thank Andres Varon and Ward Wheeler for helping with the computer implementation of the diversity measures. Thanks to Daniel Janies for useful comments on the manuscript. The technical advice of Nancy Lopez and Irma Fuxan is highly appreciated. Continuous support from the Consejo Nacional de Investigaciones Científicas y Técnicas (CONICET, <http://www.conicet.gov.ar>) is most acknowledged. This work was partially supported by FONCYT 9627 grant from the Secretaría de Ciencia y Técnica (SeCyT), Argentina.

## References

- Avalos-Ramirez, R., Orlich, M., Thiel, H.-J., Becher, P., 2001. Evidence for the presence of two novel pestivirus species. *Virology* 268, 456–465.
- Barnes, W.M., 1994. PCR amplification of up to 35-kb DNA with high fidelity and high yield from  $\lambda$  bacteriophage templates. In: Proceedings of the National Academy of Science USA, 91, pp. 2216–2220.
- Baule, C., van Vuuren, M., Lowings, J.P., Belák, S., 1997. Genetic heterogeneity of bovine viral diarrhoea virus isolated in South Africa. *Virus Res.* 52, 205–220.
- Baule, C., Kulcsar, G., Belak, K., Albert, M., Mittelholzer, C., Soos, T., Kucsera, L., Belak, S., 2001. Pathogenesis of primary respiratory disease induced by isolates from a new genetic cluster of bovine viral diarrhoea virus type I. *J. Clin. Microbiol.* 39, 146–153.
- Becher, P., Meyers, G., Shannon, A.D., Thiel, H.-J., 1996. Cytopathogenicity of border disease virus is correlated with integration of cellular sequences into the viral genome. *J. Virol.* 70, 2992–2998.
- Becher, P., Orlich, M., Kosmidou, A., König, M., Baroth, M., Thiel, H.-J., 1999. Genetic diversity of pestivirus, identification of novel groups and implications for classification. *Virology* 262, 64–71.
- Behzadian, F., Sabahi, F., Karimi, M., Sadeghizadeh, M., Maghsoudi, N., Forooshani, R.S., Shahinsaz, L., 2005. Molecular phylogenetic analysis of Iranian HDV complete genome. *Virus Genes* 30, 383–393.
- Cheng, S., Fockler, C., Barnes, W.M., Higuchi, R., 1994. Effective amplification of long targets from cloned inserts and human genomic DNA. *PNAS* 91, 5695–5699.
- Filatov, D., 1999. PROcessor of SEquences (Proseq), distributed by the author at: <http://helios.bto.ed.ac.uk/evolgen/filatov>.
- Fitch, W.M., 1971. Toward defining the course of evolution: minimum change for a specific tree topology. *Syst. Zool.* 20, 406–416.
- Fulton, R.W., Ridpath, J.F., Saliki, J.T., Briggs, R.E., Confer, A.W., Burge, L.J., Purdy, C.W., Loan, R.W., Duff, G.C., Payton, M.E., 2002. Bovine viral diarrhoea virus (BVDV) 1b, predominant BVDV subtype in calves with respiratory disease. *Can. J. Vet. Res.* 66, 181–190.
- Giribet, G., 2005. T.N.T.: Tree Analysis Using New Technology, Version 1.0, Beta test v. 0.2. In: Goloboff, P.A., Farris, J.S., Nixon, K. (Eds.), *Syst. Biol.*, vol. 54, pp. 176–178, Program and documentations available at <http://www.zmuc.dk/public/phylogeny/TNT>.
- Goloboff, P., Farris, J.S., Nixon, K., 2003. T.N.T.: Tree Analysis Using New Technology, program and documentations available from the authors, and at <http://www.zmuc.dk/public/phylogeny>.
- Herniou, E.A., Luque, T., Chen, X., Vlák, J.M., Winstanley, D., Cory, J.S., O'Reilly, D.R., 2001. Use of whole genome sequence data to infer baculovirus phylogeny. *J. Virol.* 75, 8117–8126.
- Holterman, L., Dubbes, R., Mullins, J., Haaijman, J., Heeney, J., 2000. A strategy for cloning infectious molecular clones of retroviruses from serum or plasma. *J. Virol. Meth.* 84, 37–48.
- Houe, H., 1999. Epidemiological features and economical importance of bovine virus diarrhoea virus (BVDV) infections. *Vet. Microbiol.* 64, 89–107.
- Hovenkamp, P., 2004. Review of T.N.T.—Tree Analysis Using New Technology, Version 1.0. In: Goloboff, P., Farris, J.S., Nixon, K., (Eds.), *Cladistics*, 20, pp. 378–383, available from the authors and from <http://www.zmuc.dk/public/phylogeny>.
- Jones, L.R., Cigliano, M.M., Zandomeni, R.O., Weber, E.L., 2004. Phylogenetic analysis of bovine pestivirus: testing the evolution of clinical symptoms. *Cladistics* 20, 443–453.
- Jones, L.R., Weber, E.L., 2001. Application of single strand conformational polymorphism to the study of bovine viral diarrhoea virus isolates. *J. Vet. Diagn. Investig.* 13, 48–54.
- Jones, L.R., Weber, E.L., 2004. Homologous recombination in bovine pestiviruses. Phylogenetic and statistic evidence. *Infect. Genet. Evol.* 4, 335–343.
- Jones, L.R., Zandomeni, R., Weber, E.L., 2001. Genetic typing of bovine viral diarrhoea virus from Argentina. *Vet. Microbiol.* 81, 367–375.
- Jones, L.R., Zandomeni, R., Weber, E.L., 2002. Quasispecies in the 5'-untranslated genomic region of bovine viral diarrhoea virus from a single individual. *J. Gen. Virol.* 83, 2161–2168.
- Kalinina, O., Norder, H., Mukomolov, S., Magnios, L.O., 2002. A natural intergenotypic recombinant of Hepatitis C Virus identified in St. Petersburg. *J. Virol.* 76, 4034–4043.
- Kümmerer, B.M., Stoll, D., Meyers, G., 1998. Bovine viral diarrhoea virus strain Oregon: a novel mechanism for processing of NS2-3 based on point mutations. *J. Virol.* 72, 4127–4138.
- Kümmerer, B.M., Tautz, N., Becher, P., Thiel, H., Thiel, H., Meyers, G., 2000. The genetic basis for cytopathogenicity of pestiviruses. *Vet. Microbiol.* 77, 117–128.
- Lindberg, A.M., Andersson, A., 1999. Purification of full-length enterovirus cDNA by solid phase hybridization capture facilitates amplification of complete genomes. *J. Virol. Meth.* 77, 131–137.
- Lindberg, A.M., Polacek, C., Johansson, S., 1997. Amplification and cloning of complete enterovirus genomes by long distance PCR. *J. Virol. Meth.* 65, 191–199.
- Lu, L., Nakano, T., Smallwood, G.A., Heffron, T.G., Robertson, B.H., Hagedorn, C.H., 2005. A refined long RT-PCR technique to amplify complete viral RNA genome sequences from clinical samples: application to a novel hepatitis C virus variant of genotype 6. *J. Virol. Meth.* 126, 139–148.
- Meyers, G., Tautz, N., Becher, P., Thiel, H.-J., Kümmerer, B.M., 1996. Recovery of cytopathogenic and noncytopathogenic bovine viral diarrhoea viruses from cDNA constructs. *J. Virol.* 70, 8606–8613.
- Nutall, P.A., Luther, P.D., Stot, E.J., 1977. Viral contamination of bovine foetal serum and cell cultures. *Nature* 266, 835–837.
- Oberste, M.S., Maher, K., Pallansch, M.A., 2002. Molecular phylogeny and proposed classification of the simian picornaviruses. *J. Virol.* 76, 1244–1251.
- Paton, D.J., Sands, J.J., Lowings, J.P., Smith, J.E., Ibata, G., Edwards, S., 1995. A proposed division of the pestivirus genus using monoclonal antibodies, supported by cross-neutralisation assays and genetic sequencing. *Vet. Res.* 26, 92–109.
- Pellerin, C.S., Moir, S., Lecomte, J., Tijssen, P., 1995. Comparison of the p125 coding region of bovine viral diarrhoea viruses. *Vet. Microbiol.* 45, 45–57.
- Potgieter, A.C., Steele, A.D., vanDijk, A.A., 2002. Cloning of complete genome sets of six dsRNA viruses using an improved cloning method for large dsRNA genes. *J. Gen. Virol.* 83, 2215–2223.
- Rice, C.M., 1996. Flaviviridae: the virus and their replication. In: Fields, B.N., Knipe, D.M., Howley, P.M. (Eds.), *Fields Virology* (Editorial), 3rd ed. Lippincott-Raven, USA.
- Ridpath, J.F., Bolin, S.R., 1995. The genomic sequence of a virulent bovine viral diarrhoea virus (BVDV) from the type 2 genotype: detection of a large genomic insertion in a noncytopathic BVDV. *Virology* 212, 39–46.

- Thiel, V., Rashtchian, A., Herold, J., Schuster, D.M., Guan, N., Siddell, S.G., 1997. Effective amplification of 20-kb DNA by reverse transcription PCR. *Anal. Biochem.* 252, 62–70.
- Thompson, J.D., Higgins, D.G., Gibson, T.J., 1994. CLUSTAL W, improving the sensitivity of progressive multiple sequence alignment through sequence weighting, position-specific gap penalties and weight matrix choice. *Nucl. Acid Res.* 22, 4673–4680.
- Tolou, H.J., Couissinier-Paris, P., Durand, J.P., Mercier, V., de Pina, J.J., de Micco, P., Billoir, F., Charrel, R.N., de Lamballerie, X., 2001. Evidence for recombination in natural populations of dengue virus type 1 based on the analysis of complete genome sequences. *J. Gen. Virol.* 82, 1283–1290.
- Vilček, S., Herring, A.J., Nettleton, P.F., Lowings, J.P., Paton, D.J., 1994. Pestiviruses isolated from pig, cattle and sheep can be allocated into at least three genogroups using polymerase chain reaction and restriction endonuclease analysis. *Arch. Virol.* 136, 309–323.
- Vilček, Š., Paton, D.J., Durkovic, B., Strojny, L., Ibata, G., Moussa, A., Loitsch, A., Rossmann, W., Vega, S., Scicluna, M.T., Palfi, V., 2001. Bovine viral diarrhoea virus genotype 1 can be separated into at least eleven genetic groups. *Arch. Virol.* 146, 99–115.
- Zhang, F., Huang, Q., Ma, W., Jiang, S., Fan, Y., Zhang, H., 2001. Amplification and cloning of the full-length genome of Japanese encephalitis virus by a novel long RT-PCR protocol in a cosmid vector. *J. Virol. Meth.* 96, 171–182.